



90+ GAS FURNACE INSTALLATION INSTRUCTIONS

Table of Contents

GAS FURNACE SAFETY	1	Install Condensate Disposal.....	14
INSTALLATION REQUIREMENTS	3	Install Duct Work	15
Tools and Parts	3	Filter Specifications	15
Location Requirements	3	Make Electrical Connections	16
Installation Configurations	4	Make Gas Connections.....	17
Duct Work Requirements.....	5	Check the Furnace Input Rate	17
Electrical Requirements	5	Adjust the Furnace Input Rate	18
Gas Supply Requirements	5	Complete Installation.....	19
Venting Requirements.....	5	Sequence of Operation	20
INSTALLATION INSTRUCTIONS	6	Controls	20
Inspect Shipment	6	TROUBLESHOOTING	21
Plan Vent System	7	ASSISTANCE OR SERVICE	24
Determine Vent Pipe Direction	9	Accessories	24
Connect Venting.....	14		

GAS FURNACE SAFETY

Your safety and the safety of others are very important.

We have provided many important safety messages in this manual and on your appliance. Always read and obey all safety messages.



This is the safety alert symbol.

This symbol alerts you to potential hazards that can kill or hurt you and others.

All safety messages will follow the safety alert symbol and either the word "DANGER" or "WARNING." These words mean:

! DANGER

You can be killed or seriously injured if you don't immediately follow instructions.

! WARNING

You can be killed or seriously injured if you don't follow instructions.

All safety messages will tell you what the potential hazard is, tell you how to reduce the chance of injury, and tell you what can happen if the instructions are not followed.



IMPORTANT SAFETY INSTRUCTIONS

- Use only with type of gas approved for this furnace. Refer to the furnace rating plate.
- Install this furnace only in a location and position as specified in the Location Requirements section of these instructions.
- Provide adequate combustion and ventilation air to the furnace space as specified in the “Venting Requirements” section of these instructions.
- Combustion products must be discharged outdoors. Connect this furnace to an approved vent system only, as specified in the “Venting Requirements” section of these instructions.
- Never test for gas leaks with an open flame. Use a commercially available soap solution made specifically for the detection of leaks to check all connections, as specified in the “Make Gas Connections” section of these instructions.
- Adequate clearance must be provided around the vent-air intake terminals.
- Always install furnace to operate within the furnace’s intended temperature-rise range with a duct system which has an external static pressure within the allowable range, as specified in the “Complete Installation” section of these instructions. See furnace rating plate.
- When a furnace is installed so that supply ducts carry air circulated by the furnace to areas outside the space containing the furnace, the return air shall also be handled by duct(s) sealed to the furnace casing and terminating outside the space containing the furnace.
- A gas-fired furnace for installation in a residential garage must be installed as specified in the “Location Requirements” section of these instructions.
- The furnace is not to be used for temporary heating of buildings or structures under construction.
- The furnace shall be installed so the electrical components are protected from water.
- Furnaces for indoor installation on combustible flooring shall not be installed directly on carpeting, tile or other combustible material other than wood flooring.

SAVE THESE INSTRUCTIONS

The California Safe Drinking Water and Toxic Enforcement Act requires the Governor of California to publish a list of substances known to the State of California to cause cancer, birth defects, or other reproductive harm, and requires businesses to warn of potential exposure to such substances.

WARNING: This product contains a chemical known to the State of California to cause cancer, birth defects, or other reproductive harm.

This appliance can cause low-level exposure to some of the substances listed, including benzene, formaldehyde, carbon monoxide, toluene, and soot.

ADDITIONAL SAFETY INFORMATION

In the State of Massachusetts, the following installation instructions apply:

- Installations and repairs must be performed by a qualified or licensed contractor, plumber, or gasfitter qualified or licensed by the State of Massachusetts.
- If using a ball valve, it shall be a T-handle type.
- A flexible gas connector, when used, must not exceed 3 feet.

INSTALLATION REQUIREMENTS

These instructions are intended as a general guide only for use by qualified persons and do not supersede any national or local codes in any way. Compliance with all local, state, or national codes pertaining to this type of equipment should be determined prior to installation.

Read this entire instruction manual, as well as the instructions supplied in separate equipment, before starting the installation.

The installation of the furnace, wiring, warm air ducts, venting, etc. must conform to the requirements of the National Fire Protection Association; the National Fuel Gas Code, ANSI Z223.1/NFPA No. 54 (latest edition) and the National Electrical Code, ANSI/NFPA No. 70 (latest edition) in the United States, and any state laws, local ordinances (including plumbing or wastewater codes), or local gas utility requirements. Local authorities having jurisdiction should be consulted before installation is made. Such applicable regulations or requirements take precedence over the general instructions in this manual.

This furnace design is certified by CSA International as a Category IV furnace in compliance with the latest edition of American National Standard Z21.47/CSA Standard 2.3 for Gas-Fired Central Furnaces, for operation with natural gas or propane. Consult the rating plate on the furnace for gas type before installing.

Tools and Parts

Assemble the required tools before starting installation. Read and follow the instructions provided with any tools listed here.

Tools Needed:

- Pipe wrench
- Non-corrosive leak check solution
- Screwdriver
- Test gauge with 1/8 in. NPT connection
- Tape measure
- Thread sealant (for measuring gas supply pressure)

Parts Needed:

Check local codes and with gas supplier. Check existing gas supply, electrical supply, and venting, and read "Duct Work Requirements," "Electrical Requirements," "Gas Supply Requirements" and "Venting Requirements" before purchasing parts.

Parts Supplied

- Inlet air restrictor plate
- Flue pipe screen

Location Requirements

⚠ WARNING



Explosion Hazard

Keep flammable materials and vapors, such as gasoline, away from furnace.

Place furnace so that burners are at least 18 inches (46 cm) above the floor for a garage installation.

Failure to follow these instructions can result in death, explosion, or fire.

⚠ WARNING



Explosion Hazard

Do not install this furnace in a mobile home.

Doing so can result in death, explosion, fire, or carbon monoxide poisoning.

IMPORTANT: Do not use the furnace as a heater in a building under construction. The furnace can be severely damaged due to the abnormal environment caused by construction. Chlorides from sources such as paint, stain, or varnish; tile and counter cements; adhesives; and foam insulation are abundant in a structure under construction and can be highly corrosive. Low return air temperature can cause condensation in the furnace and other damage that can shorten the life of the furnace.

- The condensate drain on this furnace is incorporated within the furnace and must be primed before start-up. The condensate system must not be exposed to temperatures under 32°F.
- The furnace is suitable for installation in buildings constructed on site. The furnace should be centralized in respect to the heat distribution system as much as practicable.

- All models are suitable for closet or utility room installation. Utility room installation requires:
A door opening large enough for the widest part of the furnace.
A door opening large enough to remove/replace any other appliance located in the utility room, such as a water heater.
Any other appliances arranged so that each appliance can be removed/replaced without disturbing the furnace.
- In a residential garage, a gas-fired furnace must be installed so the burner(s) and the ignition source are located not less than 18 in. above the floor. The furnace is to be located or protected to avoid physical damage by vehicles.
- If the furnace is to be installed in an attic or other insulated space, it must be kept free and clear of insulating materials.

Installation Clearances

- A 2 in. minimum clearance is required in front for air openings into the combustion chamber.
- All servicing and cleaning of the furnace can be performed from the front. If installed in a closet or utility room, provide 24 in. clearance in front for service if the door to the room is not in line with the front of the furnace. Where servicing clearances are greater than clearances to combustibles, servicing clearances take precedence.

Minimum Clearance to Combustibles Chart

Unit Sides	0"
Rear of Unit	0"
Front of Unit	2"
Flue Pipe	0"
Plenum Top (upflow)	1"
Supply Duct (counterflow)	1"

High Altitude Installations

- This furnace is approved for operation at altitudes from 0 to 4,500 feet above sea level without any required modifications.
- From 4,500 to 7,500 ft, the gas manifold pressure needs to be adjusted according to the information shown in the Manifold Pressure vs. Altitude charts.

IMPORTANT:

For installations above 7,500 ft, the furnace input rate is to be reduced per the requirements of the National Fuel Gas Code (ANSI Z223.1/NFPA 54, latest edition), at the rate of 4 percent for each 1,000 feet above sea level.

The furnace is not recommended for installation above 10,000 ft.

Installation Configurations

WGFDU and WFCU models must be installed only as upflow furnaces.

WGFDC and WFCC models must be installed only as counterflow (downflow) furnaces.

IMPORTANT: To ensure access to parts for servicing, install upflow and counterflow furnaces so that the burner and blower access panels are readily accessible.

Installation for Counterflow (Downflow) Models

⚠ WARNING



Fire Hazard

Before installing counterflow (downflow) furnace on combustible surface, such as wood, install one of the following kits:

- WABASE 511 (14.5" cabinets)
- WABASE 512 (17.5" cabinets)
- WABASE 568 (21" cabinets)
- WABASE 569 (24.5" cabinets)

Contact your local dealer.

Failure to do so can result in death or fire.

IMPORTANT:

- The furnace may be installed directly on the supply plenum or coil cabinet if the furnace is installed on a non-combustible floor.
 - For installations on combustible flooring, a special base must be ordered and used. See the "Accessories" section.
1. Cut, size and frame opening in floor to fit the Combustible floor base and provide a minimum 1 in. clearance between the Supply Duct and combustible materials. The four legs on the base assembly should recess into the floor and the base should rest on all four outside flanges.
 2. Construct duct connections with 1 in. to 1¼ in. right angle flanges, and long enough to extend below the floor joists.
 3. Drop the duct connections through the top of the base assembly with the right angle flanges in good contact with the glass tape on top of the base assembly.
 4. Carefully position the furnace over the right angle duct flanges.

Combustible Floor Installation (Counterflow Models only)

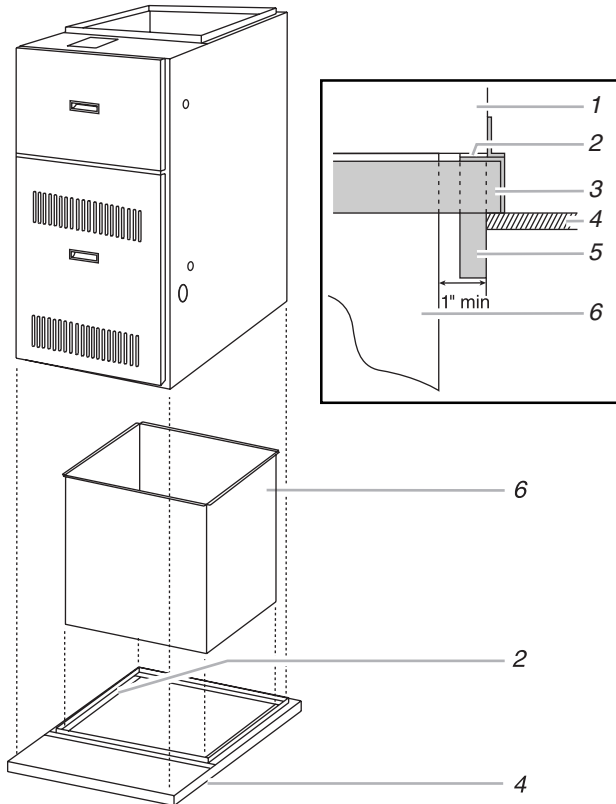

1. Furnace
2. Woven glass tape (between flanges of outlet duct and base assembly)
3. Base assembly
4. Combustible flooring
5. Leg
6. Supply plenum or coil cabinet (not provided - accessory)

Duct Work Requirements

Install the conditioned air plenum, ducts and air filters (if not provided on the furnace) in accordance with NFPA 90B Standard for the Installation of Warm Air Heating and Air-Conditioning Systems (latest edition).

The furnace is provided with flanges for the connection of the plenum and ducts.

All air filters must be listed as Class 2 furnace air filters.

Electrical Requirements

⚠ WARNING



Electrical Shock Hazard

Electrically ground furnace.

Connect ground wire to green ground screw.

Failure to do so can result in death or electrical shock.

- The furnace must be grounded and wired in accordance with local codes or, in the absence of local codes, with the National Electrical Code ANSI/NFPA No. 70 (latest edition).

- In all instances, other than wiring for the thermostat, the wiring to be done and any replacement of wire shall conform with the temperature limitation for Type T wire – 63°F (35°C) rise.
- The line voltage supply should be routed through a readily accessible disconnect located within sight of the furnace. A junction box on the furnace side panel is provided for line voltage connections. See the furnace wiring diagram for specific connection information.
- Proper polarity of the supply connections (“HOT” and “NEUTRAL”) must be observed to ensure that safety controls provide the protection intended.

Gas Supply Requirements

This furnace is equipped for use with natural gas. A conversion kit is required for use with propane. To order the correct conversion kit, see “Accessories.”

- Gas supply piping should be installed in accordance with local codes and the regulations of the utility. Piping must be of adequate size to prevent undue pressure drop. Consult the local utility or gas supplier for complete details on special requirements for sizing gas piping.
- If local codes allow the use of a flexible gas appliance connector, always use a new listed connector. Do not use a connector which has previously serviced another gas appliance.

Venting Requirements

Adequate provisions for combustion air and ventilation of furnace must be made. Refer to Section 5.3, “Air for Combustion and Ventilation,” of the National Fuel Gas Code, ANSI Z223.1/NFPA54 (latest edition), or applicable provisions of the local building codes.

Unconfined Space

An unconfined space is defined as “a space whose volume is more than 50 cubic feet per 1000 BTU per hour of the combined input rating of all appliances installed in that space.”

When a furnace is installed in an unconfined space in a building, it can be assumed that the infiltration will be sufficient to supply the required air.

If the furnace is installed in a ventilated attic or crawl space, it is assumed that the air infiltration is sufficient to supply the required combustion air. However, in a building of unusually tight construction, additional outdoor air should be provided.

Confined Space

A confined space is defined as “a space whose volume is less than 50 cubic feet per 1000 BTU per hour of the combined input rating of all appliances installed in that space.” Use Direct Vent method. See “Plan Ventilation System.”

Contaminated Combustion Air

Excessive exposure to contaminated combustion air will result in performance related problems. The recommended source of combustion air is outdoor air.

Outdoor air as the source of combustion air

If the furnace is installed in a confined space, it is recommended that the necessary combustion air come from the outdoors by way of an attic, crawl space, air duct, or direct opening.

Outdoor air is required as the source of combustion air when the indoor air is contaminated with chemical substances and in the following types of installations:

- Furnaces installed in commercial buildings
- Furnaces installed in buildings with indoor pools
- Furnaces installed in hobby or craft rooms
- Furnaces installed near chemical storage areas
- Furnaces installed in laundry rooms
- Furnaces installed in hair salons

Indoor air as the source of combustion air

Indoor air as the source of combustion air is acceptable in most applications if the following guidelines are met:

- All provisions for indoor combustion air must meet the requirements for combustion air indicated in the National Fuel Gas Code, ANSI Z223.1/NFPA 54 (latest edition), and/or any applicable local codes.
- If indoor combustion air is used, the air supply to the furnace should not be exposed to the following substances:

Permanent wave solutions

Chlorinated waxes and cleaners

Chlorine-based swimming pool chemicals

Water softening chemicals

Deicing salts or chemicals

Carbon tetrachloride

Halogen-type refrigerants

Cleaning solvents (such as perchloroethylene)

Printing inks, paint removers, varnishes, etc.

Cements and glues

Antistatic fabric softeners for clothes dryers

Masonry acid washing materials

Chlorinated laundry products

Hydrochloric acid

INSTALLATION INSTRUCTIONS

WARNING



Explosion Hazard

Furnace must be installed and serviced by a qualified person.

Examples of a qualified person include:

**licensed heating personnel,
authorized gas company personnel.**

**Read and follow all instructions provided for
installation, adjustment, service, alteration, or
maintenance.**

**Failure to follow these instructions can result in death,
explosion, fire, or carbon monoxide poisoning.**

Inspect Shipment

WARNING

Excessive Weight Hazard

Use two or more people to move and install furnace.

Failure to do so can result in back or other injury.

This furnace is shipped in one package, completely assembled and wired. The thermostat is shipped in a separate carton when ordered.

- Check the unit rating plate to confirm specifications are as ordered.
- Upon receipt of equipment, carefully inspect it for possible shipping damage. Take special care to examine the unit inside the carton if the carton is damaged.
- If damage is found, it should be noted on the carrier's freight bill. Damage claims should be filed with the carrier immediately. Claims of shortages should be filed with the seller within 5 days.

NOTE: If any damages are discovered and reported to the carrier, do not install the unit, as your claim may be denied.

Plan Vent System

The high efficiency of this furnace is accomplished by the removal of both sensible and latent heat from the flue gases. The removal of latent heat results in the condensation of moisture in the flue gases. This condensation occurs in the secondary heat exchanger and in the vent system. Therefore, this furnace requires special venting considerations and the instructions must be followed to ensure proper operation. All venting must be in accordance with the codes having jurisdiction in the area and these instructions.

IMPORTANT:

- The venting system must be supported with mounting straps to prevent any weight load from being applied to the vent blower. Horizontal vent pipe must be supported every 5 ft and vertical pipe should be supported every 10 ft to prevent sagging and provide rigid support.
- This furnace must not be connected to any Type B, BW, or L vent or vent connector and must not be connected to any portion of a factory-built or masonry chimney.
- This furnace is not to be common vented with any other appliance. The vent pipe must not be connected to a chimney flue serving a separate appliance designed to burn solid fuel.

Venting Options

WFCU, WFCC, WGFDC and WGFDU models can be installed as either direct vent or non-direct vent units.

For either type of installation, special venting considerations must be followed. See “Determine Vent Pipe Direction” section for the type of furnace and venting being installed.

Direct Vent

A direct vent (two pipe) installation requires that all the air necessary for combustion be supplied from outside the dwelling through an air intake pipe.

- All vents passing through floors, ceilings, and walls must be installed in accordance with National Fuel Gas Code, ANSI Z223.1/NFPA 54 (latest edition). In all applications where the flue pipe is run through an unconditioned space, ½ in. insulation must be used over the pipe. In extremely cold climates, ¾ in. insulation is recommended.

Non-Direct Vent

A non-direct vent (one pipe) installation uses air from inside the dwelling for combustion.

- The furnace is shipped with the air inlet pipe terminated to the top panel for either inside or outside combustion air. An inlet air restrictor plate is supplied with this furnace and can be found in the plastic bag containing these Installation Instructions and the User’s Information Manual.
- For installations using inside air for combustion (non-direct vent), attach a 90° elbow (not supplied) to the inlet coupler and install the restrictor plate inside the elbow (see “Non-Direct Vent Installation”).

Inlet Air Restrictor Plate

The inlet air restrictor plate must be installed in all installations using inside air for combustion (non-direct vent).

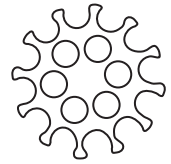

Flue Pipe Screen

A flue pipe screen designed to keep objects out of the flue pipe is included in the plastic bag.

In all installations, this screen should be installed at the termination of the flue pipe.

Flue Pipe Screen

The flue pipe screen should be installed at the termination of the flue pipe in all installations.

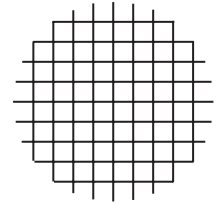

Materials

- All pipe, fittings, primer, and solvent cement must conform with American National Standard Institute and the American Society for Testing and Materials (ANSI/ASTM) standards. The solvent shall be free flowing and contain no lumps, undissolved particles, or any foreign matter that adversely affects the joint strength or chemical resistance of the cement. The cement shall show no gelatinization, stratification, or separation that cannot be removed by stirring. See "Piping and Fitting Specifications" for approved piping and fitting materials.

Piping and Fitting Specifications

Piping and Fitting Material	ASTM Specification
Schedule 40 PVC (Pipe)	D1785
Schedule 40 PVC (Cellular Core Pipe)	F891
Schedule 40 PVC (Fittings)	D2466
SDR-26 (Pipe)	D2241
Schedule 40 ABS (Pipe)	D1527
Schedule 40 ABS (Fittings)	D2468
Schedule 40 & 80 CPVC (Pipe)	F441
ABS-DWV Drain Waste & Vent (Pipe & Fittings)	D2661
PVC-DWV Drain Waste & Vent (Pipe & Fittings)	D2665

- The primers and solvents used must also meet ASTM specifications. PVC primer is specified in ASTM F656. Use PVC solvent as specified in ASTM D2564 and ABS solvent cement as specified ASTM D2235. Low temperature solvent cement is recommended. Metal or plastic strapping may be used for vent pipe hangers.
- When making ABS joints, pieces can be prepared with a cleaner. When joining ABS to PVC materials, use PVC solvent cement as specified in ASTM D3138.
- Preferred fittings are DWV style or long sweep. Seal all joints gas tight with appropriate cement. In areas where vent and air intake pipes are exposed to abnormal stress or are subject to damage, schedule 80 pipe should be used.
- Use high temperature RTV silicone sealant to attach the air intake pipe into the connector on the burner box so the air intake pipe can be removed if service is required.

NOTE: Do not use cement.

Vent Pipe Size and Length

The vent pipe and air intake pipe (in direct vent installations) should be sized in accordance with the information found in the "Vent Tables." One 90° elbow is equivalent to 5 ft of pipe. Two 45° elbows are equivalent to one 90° elbow. The minimum length certified for use with this furnace is 5 ft and one elbow, not including the vent and air intake terminals.

Vent Table - 40,000 - 80,000 BTU/HR Models

Vent Pipe Length (ft)	Minimum Pipe Diameter (in.)									
	1.5	1.5	2	2	2	2	2	2	2	2
5	1.5	1.5	2	2	2	2	2	2	2	2
10	1.5	2	2	2	2	2	2	2	2	2
20	2	2	2	2	2	2	2	2	2	2.5
30	2	2	2	2	2	2	2	2.5	2.5	2.5
40	2	2	2	2	2	2.5	2.5	2.5	2.5	2.5
50	2	2	2.5	2.5	2.5	2.5	2.5	2.5	2.5	NR
60	2	2.5	2.5	2.5	2.5	2.5	2.5	NR	NR	NR
70	2.5	2.5	2.5	2.5	2.5	NR	NR	NR	NR	NR
80	2.5	2.5	2.5	NR	NR	NR	NR	NR	NR	NR
90	2.5	2.5	NR	NR	NR	NR	NR	NR	NR	NR
Number of 90° Elbows	0	1	2	3	4	5	6	7	8	9
NR = Not Recommended										

Vent Table- 90,000 - 100,000 BTU/HR Models

Vent Pipe Length (ft)	Minimum Pipe Diameter (in.)									
	NR	2	2	2	2	2	2	2.5	2.5	2.5
5	NR	2	2	2	2	2	2	2.5	2.5	2.5
10	2	2	2	2	2	2	2.5	2.5	2.5	2.5
20	2	2	2	2	2	2.5	2.5	2.5	2.5	3
30	2	2	2	2.5	2.5	2.5	2.5	3	3	3
40	2	2	2.5	2.5	2.5	3	3	3	3	3
50	2.5	2.5	2.5	3	3	3	3	3	3	NR
60	2.5	3	3	3	3	3	3	NR	NR	NR
70	3	3	3	3	3	NR	NR	NR	NR	NR
80	3	3	3	NR	NR	NR	NR	NR	NR	NR
90	3	3	NR	NR	NR	NR	NR	NR	NR	NR
Number of 90° Elbows	0	1	2	3	4	5	6	7	8	9
NR = Not Recommended										

Vent Table - 112,000 - 125,000 BTU/HR Models

Vent Pipe Length (ft)	Minimum Pipe Diameter (in.)									
	2.5	2.5	2.5	2.5	2.5	2.5	2.5	2.5	2.5	2.5
5	2.5	2.5	2.5	2.5	2.5	2.5	2.5	2.5	2.5	2.5
10	2.5	2.5	2.5	2.5	2.5	2.5	2.5	2.5	2.5	3
20	2.5	2.5	2.5	2.5	2.5	2.5	2.5	3	3	NR
30	2.5	2.5	2.5	2.5	2.5	3	3	NR	NR	NR
40	2.5	2.5	2.5	2.5	3	NR	NR	NR	NR	NR
50	2.5	3	3	NR	NR	NR	NR	NR	NR	NR
60	3	3	NR	NR	NR	NR	NR	NR	NR	NR
Number of 90° Elbows	0	1	2	3	4	5	6	7	8	9
NR = Not Recommended										

In the event that the pipe length is in between the lengths listed in the Vent Table, use the next larger length listed. For example, if a length of pipe needed to install the furnace is 27 ft, use the diameter values for the 30 ft row in the tables.

For direct vent installations, if the vent and air intake pipe are not equal in length and number of elbows, then determine the minimum pipe diameter for both the vent and air intake. If the results indicate different diameters, use the larger of the two for both the vent and air intake.

NOTE: Under no circumstances should the vent and air intake pipe size be different in diameter. See “Install Vent System” for the unit model and type of installation.

Determine Vent Pipe Direction

The vent system of the furnace must be self-supporting and must not apply any weight load to the combustion blower.

Combustion Air Sources

There are 2 sources for combustion air:

1. From outside the building (Direct Vent)
2. From inside the building (Non-Direct Vent)

Please read the information provided here about Vertical and Horizontal Venting, then find and follow the instructions for your venting configuration.

Vertical Venting

A vertical vent should extend through the roof a minimum of 2 ft and not be obstructed a minimum of 10 ft in any direction.

Horizontal Venting

The vent terminal location shall comply with Section 7.8 of the National Fuel Gas Code (ANSI Z223.1) or local requirement, whichever takes precedence. For informational purposes, the applicable sections of Section 7.8 are reprinted here:

The venting system shall terminate at least 3 feet (0.9 m) above any forced air inlet located within 10 feet (3.1 m). This provision shall not apply to the combustion air inlet of a direct vent appliance or to the separation of the circulating air inlet and vent discharge of a listed outdoor appliance.

For non-direct vent installation, the vent system shall terminate at least 4 feet (1.2 m) below, 4 feet (1.2 m) horizontally from, or 12 inches (30 cm) above any door, window, or gravity inlet into any building. The bottom of the vent terminal shall be located at least 12 inches (30 cm) above grade or maximum expected snow depth.

For direct vent installation of models with an input rating of 50,000 BTUH or less, the vent system shall terminate at least 9 inches (23 cm) from any opening through which flue gases could enter a building. For direct vent installation of models with an input greater than 50,000 BTUH, the vent system shall terminate at least 12 inches (30 cm) from any opening through which flue gases could enter a building.

Regardless of input, the vent terminal and air intake shall terminate at least 12 inches (30 cm) above grade or maximum expected snow depth.

The vent system, regardless of installation type, shall terminate a minimum horizontal clearance of 4 ft from electric meters, gas meters, regulators, and relief equipment.

Direct Vent Installation Upflow Models

- Refer to the appropriate vent table for proper pipe size, vent length and the number of elbows allowed, and air intake length and the number of elbows allowed.
- Refer to the "Materials" section for the proper venting material.
- Do not install the inlet air restrictor plate in any direct vent installation. The inlet air restrictor plate (see "Inlet Air Restrictor Plate" section) supplied with this furnace is to be used only in non-direct vent applications.
- The flue pipe screen, designed to keep objects out of the flue pipe (see "Flue Pipe Screen" section), should be installed at the termination of the flue pipe.

NOTE: Do not place an additional flue pipe screen in the intake termination because the air intake may freeze shut.

- For proper operation, the vent and air intake pipe must be installed in the same pressure zone. Therefore, in horizontal venting applications they must be on the same side of the house within the parameters as shown.

NOTE: The 18 in. dimension shown below is the minimum recommended height for extremely cold areas. In these areas, moisture in the flue gases may condense and freeze on the air intake if this height is reduced. In milder climates, this may be reduced to a minimum of 6 in. Height may be increased as needed provided total length of pipe to furnace is not exceeded.

Direct Vent-Upflow (Horizontal Venting)

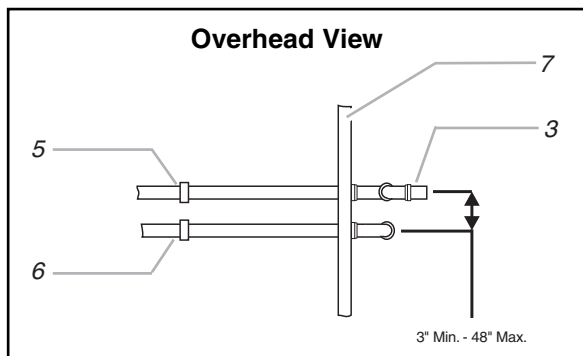
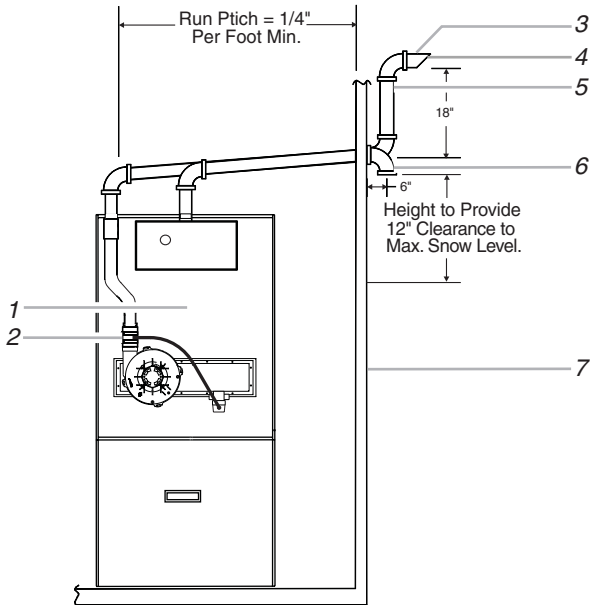

- | | |
|----------------------|--|
| 1. Air intake pipe | 4. Flue pipe screen (inside flue pipe) |
| 2. Condensate collar | 5. Flue pipe |
| 3. Optional piece | 6. Air intake pipe |
| | 7. Wall |

Direct Vent - Upflow (Vertical Venting)

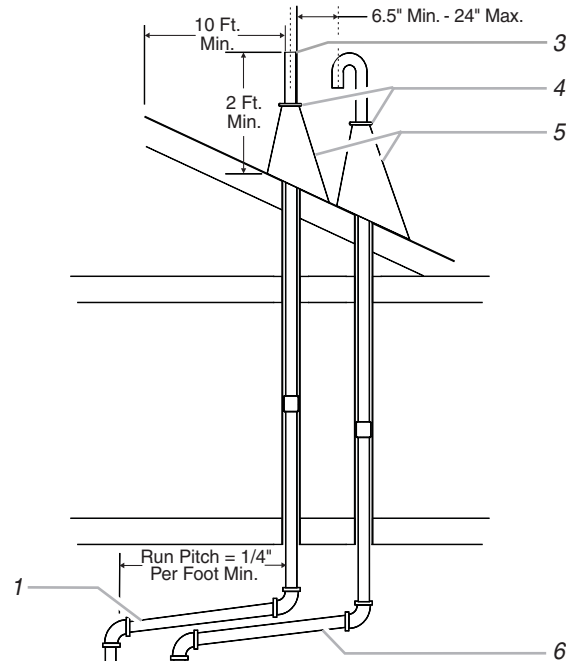

- | | |
|--|--------------------|
| 1. Flue pipe | 4. Storm collars |
| 2. Condensate collar | 5. Flashing |
| 3. Flue pipe screen (inside flue pipe) | 6. Air intake pipe |

Non-Direct Vent Installation - Upflow Models

- Refer to appropriate tables for proper pipe size, vent length and the number of elbows allowed.
- Refer to the "Materials" section for the proper venting material.
- An inlet air restrictor plate found in the plastic bag containing these Installation Instructions and the User's Information Manual must be installed in all non-direct vent installations. See the "Inlet Air Restrictor Plate" section. Attach a 90° elbow (not supplied) to the inlet coupler and install the inlet air restrictor plate inside the elbow.
- The flue pipe screen, designed to keep objects out of the flue pipe (see "Flue Pipe Screen" section), should be installed at the termination of the flue pipe.

Non-Direct Vent Upflow - Horizontal Venting

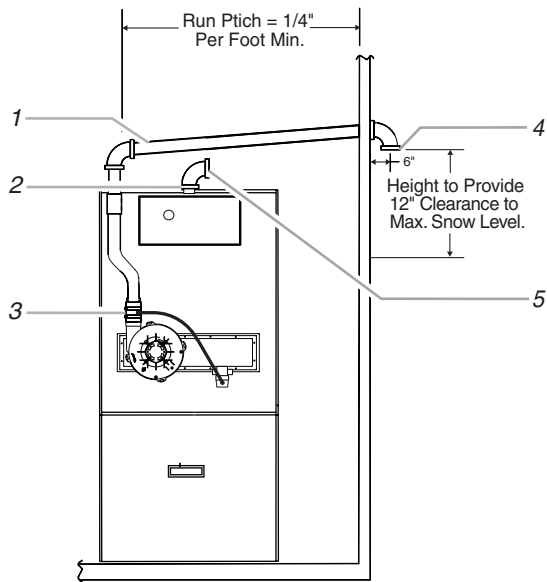

- | | |
|----------------------|---|
| 1. Flue pipe | 4. Flue pipe screen (inside flue pipe) |
| 2. Air intake pipe | 5. Inlet air restrictor plate (inside intake pipe or elbow) |
| 3. Condensate collar | |

Non-Direct Vent Upflow - Vertical Venting

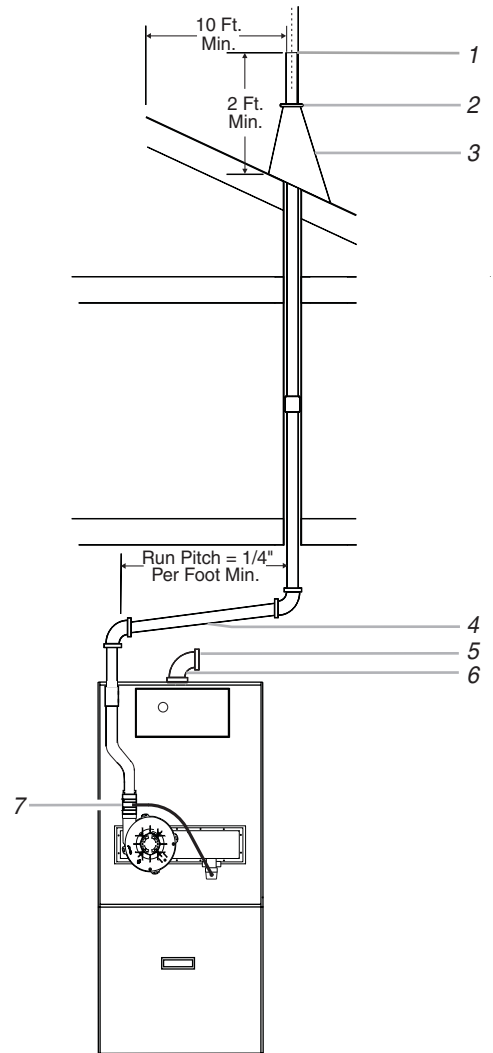

- | | |
|--|---|
| 1. Flue pipe screen (inside flue pipe) | 5. Inlet air restrictor plate (inside intake pipe or elbow) |
| 2. Storm collar | 6. Air intake pipe |
| 3. Flashing | 7. Condensate collar |
| 4. Flue pipe | |

Direct Vent Installation - Counterflow Models

- Refer to appropriate tables for proper pipe size, vent length and the number of elbows allowed, and air intake length and the number of elbows allowed.
- Refer to the "Materials" section for the proper venting material.
- Do not install the inlet air restrictor plate in any direct vent installation. The inlet air restrictor plate (see "Inlet Air Restrictor Plate" section) supplied with this furnace is to be used only in non-direct vent applications.
- The flue pipe screen, designed to keep objects out of the flue pipe (see "Flue Pipe Screen" section), should be installed at the termination of the flue pipe.

NOTE: Do not place an additional flue pipe screen in the intake termination because the air intake may freeze shut.

- For proper operation, the vent and air intake pipe must be installed in the same pressure zone. Therefore, in horizontal venting applications they must be on the same side of the house within the parameters as shown.

NOTE: The 18 in. dimension shown in "Direct Vent Counterflow - Horizontal Venting" is the minimum recommended height for extremely cold areas. In these areas, moisture in the flue gases may condense and freeze on the air intake if this height is reduced. In milder climates, this may be reduced to a minimum of 6 in. Height may be increased as needed provided total length is not exceeded.

Direct Vent Counterflow - Horizontal Venting

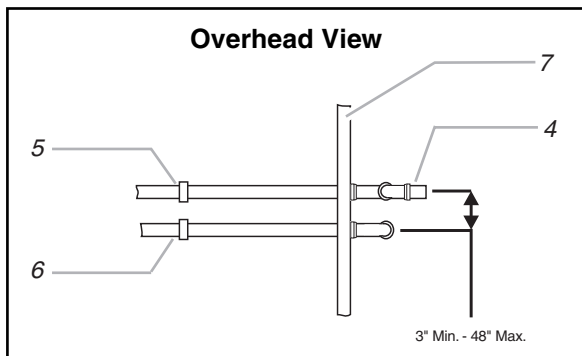
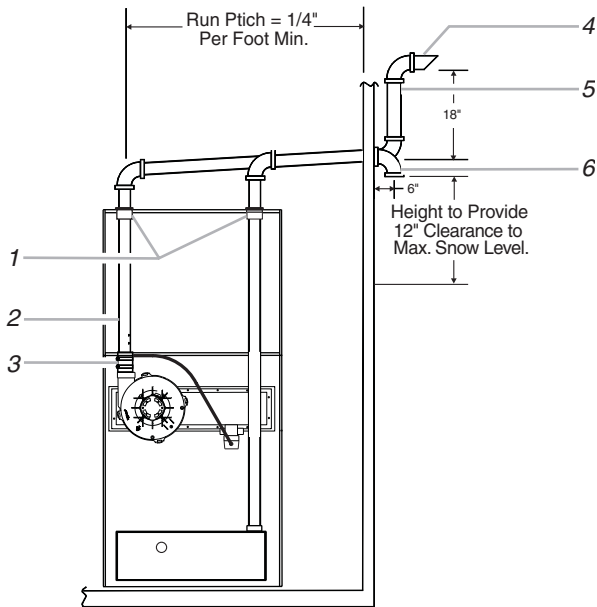

- | | |
|----------------------|--|
| 1. PVC collars | 5. Flue pipe screen (inside flue pipe) |
| 2. Flue pipe | 6. Air intake pipe |
| 3. Condensate collar | 7. Wall |
| 4. Optional piece | |

Direct Vent Counterflow- Vertical Venting

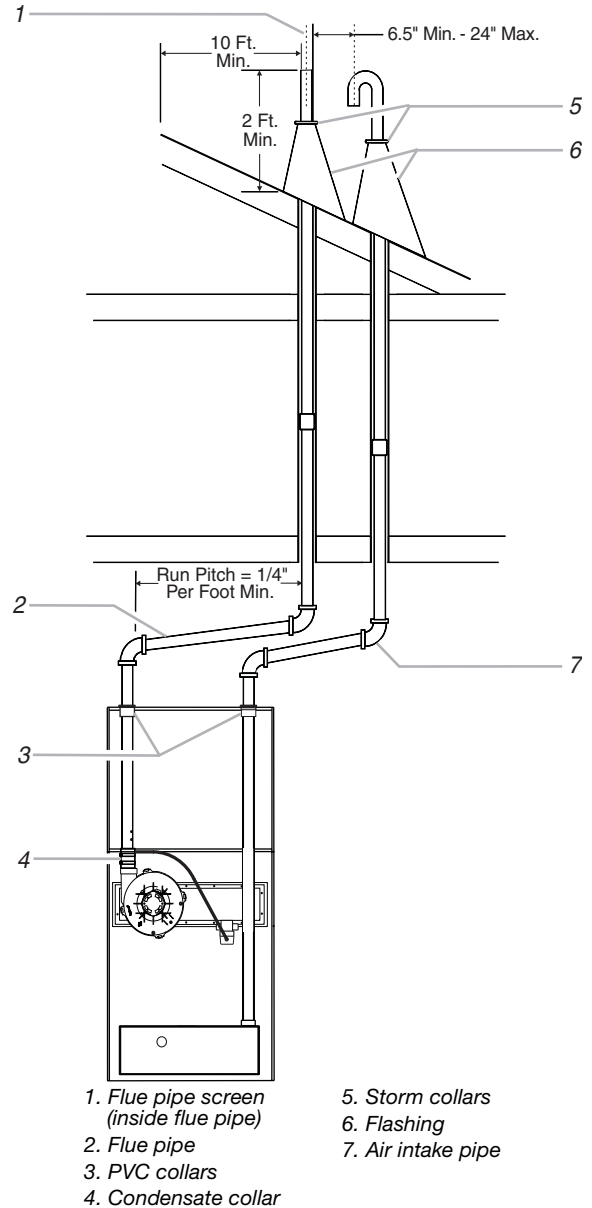

- The 45,000 and 67,000 BTU per hour models contain an inlet air assembly that uses two 22.5° elbows that attach separately from the straight inlet pipe, as shown. This allows the inlet pipe assembly to be removed if needed for service.

Inlet Air Assembly- 45,000 & 67,000 BTU/HR Units

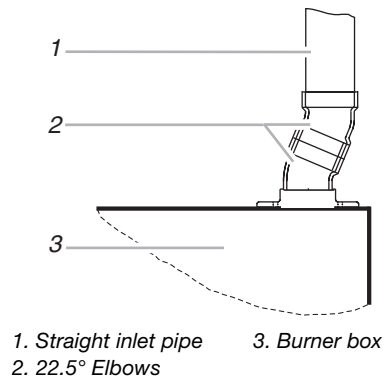

Non-Direct Vent Installation- Counterflow Models

- Refer to appropriate tables for proper pipe size, vent length and the number of elbows allowed.
- Refer to the "Materials" section for the proper venting material.
- An inlet air restrictor plate found in the plastic bag containing these Installation Instructions and the Use and Care Guide must be installed in all non-direct vent installations. See the "Inlet Air Restrictor Plate" section. Attach a 90° elbow (not supplied) to the inlet coupler and install the inlet air restrictor plate inside the elbow.
- The flue pipe screen, designed to keep objects out of the flue pipe (see "Flue Pipe Screen" section), should be installed at the termination of the flue pipe.

Non-Direct Vent Counterflow - Horizontal Venting

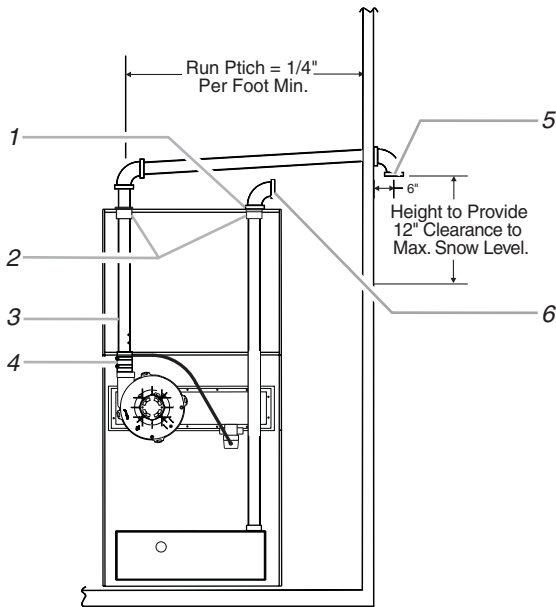

- | | |
|------------------|---|
| 1. Inlet coupler | 4. Condensate collar |
| 2. PVC collars | 5. Flue pipe screen (inside flue pipe) |
| 3. Flue pipe | 6. Inlet air restrictor plate (inside intake pipe or elbow) |

Non-Direct Vent Counterflow - Vertical Venting

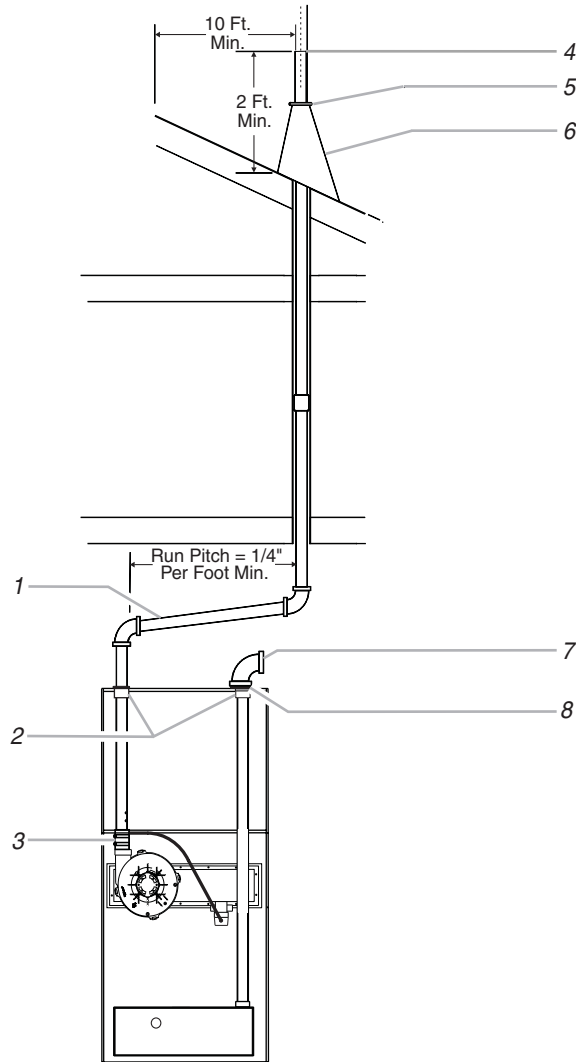

- | | |
|--|---|
| 1. Flue pipe | 5. Storm collar |
| 2. PVC collars | 6. Flashing |
| 3. Condensate collar | 7. Inlet air restrictor plate (inside intake pipe or elbow) |
| 4. Flue pipe screen (inside flue pipe) | 8. Air intake pipe |

- The 45,000 and 67,000 BTU per hour models contain an inlet air assembly that uses two 22.5° elbows that attach separately from the straight inlet pipe, as shown. This allows the inlet pipe assembly to be removed if needed for service.

Inlet Air Assembly - 45,000 & 67,000 BTU/HR Units

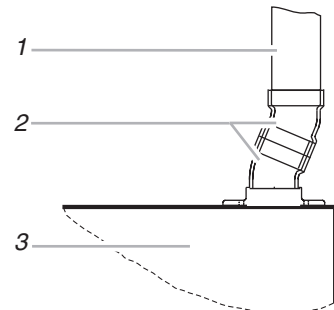

- | | |
|------------------------|---------------|
| 1. Straight inlet pipe | 3. Burner box |
| 2. 22.5° Elbows | |

Existing Venting Systems

When an existing furnace is removed or replaced, the original venting system may no longer be sized to properly vent the attached appliances. An improperly sized venting system can result in spillage of flue products into the living space, the formation of condensate, leakage, etc. See the "Carbon Monoxide Poisoning Hazard" for proper test procedure.

WARNING:

CARBON MONOXIDE POISONING HAZARD

Failure to follow the steps outlined below for each appliance connected to the venting system being placed into operation could result in carbon monoxide poisoning or death.

The following steps shall be followed for each appliance connected to the venting system being placed into operation, while all other appliances connected to the venting system are not in operation:

1. Seal any unused openings in the venting system.
2. Inspect the venting system for proper size and horizontal pitch, as required in the National Fuel Gas Code, ANSI Z223.1/NFPA 54 or the CSA B149.1, Natural Gas and Propane Installation Codes and these instructions. Determine that there is no blockage or restriction, leakage, corrosion and other deficiencies which could cause an unsafe condition.
3. As far as practical, close all building doors and windows and all doors between the space in which the appliance(s) connected to the venting system are located and other spaces of the building.
4. Close fireplace dampers.
5. Turn on clothes dryers and any appliance not connected to the venting system. Turn on any exhaust fans, such as range hoods and bathroom exhausts, so they are operating at maximum speed. Do not operate a summer exhaust fan.
6. Follow the lighting instructions. Place the appliance being inspected into operation. Adjust the thermostat so appliance is operating continuously.
7. Test for spillage from draft hood equipped appliances at the draft hood relief opening after 5 minutes of main burner operation. Use the flame of a match or candle.
8. If improper venting is observed during any of the above tests, the venting system must be corrected in accordance with the National Fuel Gas Code, ANSI Z223.1/NFPA 54 and/or CSA B149.1, Natural Gas and Propane Installation Codes.
9. After it has been determined that each appliance connected to the venting system properly vents when tested as outlined above, return doors, windows, exhaust fans, fireplace dampers and any other gas-fired burning appliance to their previous conditions of use.

Connect Venting

1. Run venting to the furnace, see "Plan Vent System."
2. Attach the air intake pipe to the furnace connector.
Use high temperature RTV silicone sealant to attach the air intake pipe into the connector on the burner box so the air intake pipe can be removed if service is required.
NOTE: Do not use cement.
3. For non-direct vent installations only, install the inlet air restrictor plate in the air inlet pipe.
4. Attach the flue pipe connector to the furnace.
5. For both direct and non-direct vent installations, install the flue pipe screen at the outside end of the flue pipe.
6. Make sure all vent connections do not leak.
7. Check that the exhaust vent pipe terminates outside the building.
8. Prime the trap system by slowly pouring 1 cup of water down the vent pipe. The vent pipe on horizontal runs must slope upward, away from the furnace, at a minimum pitch of $\frac{1}{4}$ in. per foot of run, to prevent accumulation of condensate.
NOTE: On initial start-up of the unit, some of the water used to prime the trap system may run down into the combustion blower and cause noise.

Install Condensate Disposal

IMPORTANT: The condensate drain should be routed directly to a locally acceptable disposal area. The condensate drain line should not be run directly to the outdoors especially in colder climates where temperatures may cause the condensate to freeze in the drain line.

1. Connect the $\frac{1}{2}$ in. NPT x $\frac{3}{4}$ in. PVC adapter (supplied) in the drain on the side that the draining will occur.
NOTE: The condensate can be drained from either the right or left side of the furnace.
2. Connect the plastic pipe plug opposite of the drain.
3. Connect $\frac{3}{4}$ in. PVC pipe, make a connection from the adapter just installed to extend just outside the unit. Install a $\frac{3}{4}$ in. PVC tee as shown.
4. From the tee, connect the drain to the disposal area.
NOTE: The top of the tee must be left open for proper condensate drainage. The open end of the tee must be oriented so that the condensate does not run out of this opening.

Condensate Disposal

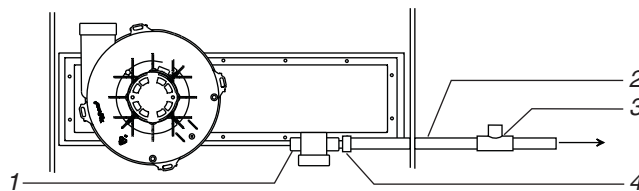

1. $\frac{1}{2}$ in. NPT plug (supplied)
2. $\frac{3}{4}$ in. PVC

3. Tee (must remain open)
4. $\frac{1}{2}$ in. NPT x $\frac{3}{4}$ in. PVC adapter (supplied)

Install Duct Work

IMPORTANT:

- Install duct work in accordance with NFPA 90B and any local codes.
- If there is no complete return air duct system, the return air connection must be sealed to the furnace casing and run full size to a location outside the utility room or space housing the furnace to prevent a negative pressure on the venting system.

Installation with Return Ducts

A return air duct system is recommended. If the unit is installed in a confined space or closet, a return connection must be run, full size, to a location outside the closet. The air duct in the closet must be tight to prevent any entrance of air from the closet into the circulating air.

Installation with an Evaporator Coil

When an air conditioning unit is used in conjunction with the furnace, the evaporator coil must be installed in the discharge (supply) air. Do not install an evaporator coil in the return air; excessive condensation will occur within the furnace.

Installation without an Evaporator Coil

If a cooling coil is not installed with the furnace, then a removable access panel should be provided in the supply plenum for purposes of inspecting the heat exchanger. This opening must be accessible when the furnace is installed. It must be large enough that the heat exchanger can be viewed for possible openings using light assistance or so that a probe can be inserted for sampling the airstream. The cover for the opening must be leak tight.

Filter Specifications

Upflow Models

A filter rack and cleanable 16 in. x 25 in. x 1/2 in. filter are supplied with model WGFDU only. Filter rack and filters are not supplied with models WFCU, WFCC, or WGFDC. (Models designed for more than 1600 CFM nominal air delivery include two of each.)

Some model furnaces can be installed with either a side or bottom air return. For bottom air return the bottom air return knockout plate must be removed. For units that do not include a side or bottom return filter rack, kit no. AFILT524-1 (side return) or kit no. AFILT529-1 (bottom return) can be used.

To provide sufficient filter area for installations requiring more than 1600 CFM nominal air delivery, return air will have to be brought through both sides of the furnace, or through one side and the bottom, or an optional filter rack WAFILTHA7 may be used.

Counterflow Models

Filters are not supplied with these furnaces; however, filters must be used. It is the installer's responsibility to install a filter rack with the ductwork and to install properly sized filters in accordance with the "Minimum Filter Requirements Chart."

- The Airflow Descriptor is the 2 digits immediately preceding the hyphen (-) in the furnace model number. Example: 16 is the Airflow Descriptor for furnace model WFAT075B16-1A. The model number is located on the rating plate inside the access panel.
- Areas and dimensions shown for cleanable filters are based on filters rated at 600 ft per minute face velocity.
- Typical filter sizes are shown; however, any combination of filters whose area equals or exceeds the minimum area shown is satisfactory.

Minimum Filter Requirements Chart

Airflow Descriptor	Disposable Filters			Cleanable Filters		
	Min. Area (sq. in.)	Size (in.)	Qty.	Min. Area (sq. in.)	Size (in.)	Qty.
09	480	20 x 25	1	240	16 x 20	1
10	480	20 x 25	1	240	16 x 20	1
12	576	16 x 20	2	288	16 x 20	1
14	672	20 x 20	2	336	20 x 20	1
16	768	20 x 20	2	384	20 x 20	1
20	960	20 x 25	2	480	20 x 25	1

If a central return air filter-grille is used, the furnace does not require a filter.

To install a filter at the furnace only, use the following kits:

- AFILT524 for side return on upflow installations.
- AFILT529 for bottom return on upflow furnace installations.
- WAFILTHA7 for single side return in installations requiring more than 1600 CFM nominal air delivery.

Make Electrical Connections

⚠ WARNING



Electrical Shock Hazard

Disconnect power before servicing.

Replace all parts and panels before operating.

Failure to do so can result in death or electrical shock.

Thermostat

Install a room thermostat according to the instructions furnished with it. Select a location on an inside wall that is not subject to drafts, direct sunshine, or other heat sources.

Make the low voltage thermostat connections to the blower control board as indicated on the Wiring Connection Diagram.

Continuous Low Speed Blower

If continuous blower operation on low speed is desired, connect the low speed motor tap to the CONT (constant) air terminal on the blower control board. See the Wiring Connection Diagram. The blower will operate on low speed whenever the main power is connected to the furnace, except when it operates on heating or cooling speed during thermostat call for heat or cooling.

NOTE: The constant air terminal is to be connected to the low speed motor tap only. If a motor is wired for a higher speed, the increased amp draw could cause the board control to fail and void the warranty.

1. Disconnect power.
2. Remove the screw from the furnace electrical connection box.
3. Remove the cover from the furnace electrical connection box.
4. Route the field supply wires to the furnace electrical connection box.

5. Using UL listed wire nuts, connect the field supply wires to the furnace (black to black and white to white).

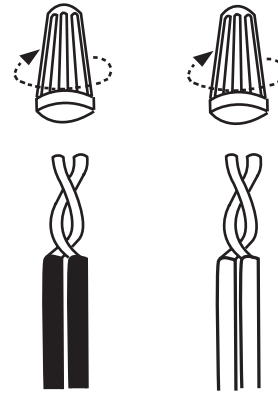

⚠ WARNING



Electrical Shock Hazard

Electrically ground furnace.

Connect ground wire to green ground screw.

Failure to do so can result in death or electrical shock.

6. Connect ground wire to green ground screw.

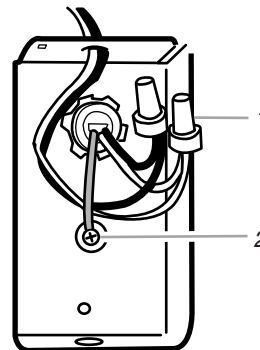

1. Connect white to white and black to black
2. Green ground screw

7. Replace the furnace electrical connection box cover and screw.

Make Gas Connections

IMPORTANT: This furnace requires conversion for use with propane. To order the correct conversion kit, see “Accessories.”

1. Install the field gas supply as shown.
2. Provide a sediment trap on the outside of the furnace.
3. Install a manual gas shutoff valve in the gas line, outside the unit, 5 ft above the floor, or in accordance with any local codes.
4. Install a test gauge connection with a 1/8 in. NPT plugged tapping immediately upstream of the manual gas shutoff valve as shown.
5. Connect the gas pipe to the furnace controls providing a ground joint union as close to the controls as possible to facilitate removal of controls and manifold.

Pipe-joint compounds suitable for use with natural and LP gas must be used. Do not use Teflon® tape.

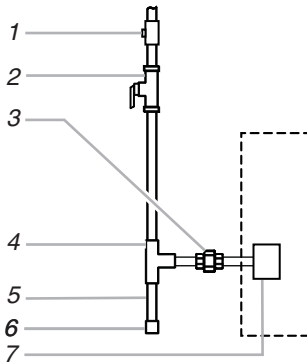

- | | |
|--------------------------------|---------------------------------------|
| 1. 1/8 in. NPT plugged tapping | 5. Sediment trap |
| 2. Manual gas shutoff valve | 6. Cap |
| 3. Ground joint union | 7. Gas control valve (inside furnace) |
| 4. Tee | |

WARNING

FIRE OR EXPLOSION HAZARD

Failure to follow the safety warnings exactly could result in serious injury, death or property damage.

Never test for gas leaks with an open flame. Use a commercially available soap solution made specifically for the detection of leaks to check all connections. A fire or explosion may result causing property damage, personal injury or loss of life.

6. Turn off the gas supply at the manual gas shutoff valve.

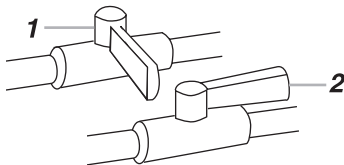

1. Closed valve
2. Open valve

7. Remove the inlet pressure tap plug on the gas control valve and connect pressure gauge to the 1/8 in. NPT inlet pressure tap.
8. Turn on the gas supply at the manual gas shutoff valve.
9. Observe the inlet pressure.
The minimum inlet gas supply pressure is 5 in. W.C. for natural gas and 11 in. W.C. for propane gas.
The maximum inlet gas supply pressure is 10.5 in. W.C. for natural gas and 13 in. W.C. for propane gas.
10. Turn off the gas supply at the manual gas shutoff valve.
IMPORTANT: If the inlet gas supply pressure is not within the minimum and maximum range as shown on the rating plate, contact your gas supplier.
11. Disconnect the pressure gauge from the 1/8 in. NPT inlet pressure tap.
12. Replace the inlet pressure tap plug on the gas control valve.
13. Turn on the gas supply at the manual gas shutoff valve.
14. Test all connections by brushing on an approved non-corrosive leak-detection solution. Bubbles will show a leak. Correct any leak found.
 - At test pressures greater than 1/2 psig (3.5 kPa), the furnace and the manual gas shutoff valve must be disconnected from the gas supply piping system.
 - At test pressures less than or equal to 1/2 psig (3.5 kPa), the furnace must be isolated from the gas supply piping system by closing the manual gas shutoff valve.
15. Replace the burner access door.

Check the Furnace Input Rate (if required)

IMPORTANT:

- The furnace input rate must not exceed the input rating on the furnace rating plate.
 - At altitudes from 2,000 to 7,500 ft the furnace input rate must not exceed that on the rating plate multiplied by the Input Factor in the Manifold Pressure vs. Altitude chart.
 - This furnace is equipped for rated input at manifold pressures of 3.5 in. W.C. for natural gas and 10.0 in. W.C. for propane gas.
1. For natural gas, check the furnace rate by observing the gas meter, making sure all other gas appliances are turned off. The test hand on the meter should be timed for at least one revolution.

$$\text{BTU/HR} = \frac{\text{Cubic feet per Revolution} \times 3600 \times \text{Heating Value}}{\text{\# Seconds per Revolution}}$$

2. The actual heating value of your gas can be obtained from your local utility company.

Adjust the Furnace Input Rate (if required)

For altitudes 4,500 to 7,500 feet above sea level.

1. Remove the burner access door.
2. Move the gas control switch to the OFF position. Use only your hand to move the gas control switch; tools are not required.
3. Remove the outlet pressure tap plug on the gas control valve and connect pressure gauge to the 1/8 in. NPT outlet pressure tap.

Gas Control Valve

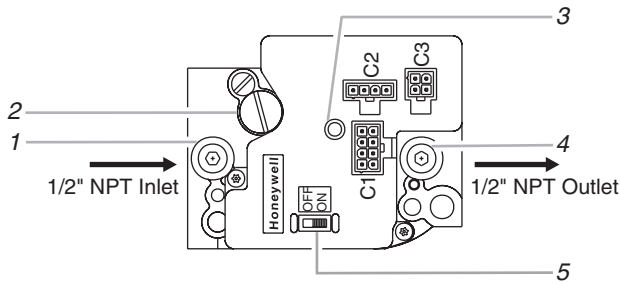

1. 1/8" NPT Inlet pressure tap
2. Regulator adjusting cap
3. Diagnostic LED
4. 1/8" NPT Outlet pressure tap
5. Gas control switch

4. Be sure the gas control switch has been in the OFF position for at least 5 minutes before starting the unit.
5. Move the gas control switch to the ON position.
NOTE: This furnace is equipped with an ignition device which automatically lights the burner. This furnace cannot be lighted manually. Do not try to light the burner by hand.
6. Turn on the electrical power to the furnace.
7. Set the room thermostat to a point above room temperature to light the main burners.
8. Observe the pressure reading on the pressure gauge.

9. Refer to the Manifold Pressure vs. Altitude chart for the correct manifold pressure. If necessary, remove the regulator adjusting cap on the gas valve and turn the regulator adjusting screw clockwise to increase pressure and input, or counterclockwise to decrease pressure and input.

IMPORTANT: If the manifold pressure cannot be adjusted to the correct value, contact your gas supplier.

10. Move the gas control switch to the OFF position.
11. Disconnect the pressure gauge from the 1/8 in. NPT outlet pressure tap.
12. Replace outlet pressure tap plug and the regulator adjusting cap on the gas valve.
13. Move the gas control switch to the ON position.
14. Replace the burner access door.
15. Set the room thermostat to the desired temperature necessary to achieve optimum temperature rise.

Manifold Pressure vs. Altitude Chart

Natural Gas			
Altitude (ft)	Heating Value (BTU/ft ³)	Manifold Pressure (in. W.C.)	Input Factor
2000	948	3.50	0.9666
3000	914	3.50	0.9499
4000	881	3.50	0.9332
4500	865	3.50	0.9249
5000	849	3.29	0.8900
5500	833	3.27	0.8790
6000	818	3.25	0.8680
6500	802	3.23	0.8570
7000	787	3.21	0.8460
7500	771	3.19	0.8350

For Altitudes 7,500 to 10,000 feet above sea level.

Do not adjust manifold pressure. An orifice change is required. For the correct orifice size, see Table F.4 in Appendix F of the National Fuel Gas Code (ANSI Z223.1/NFPA 54, latest edition).

Complete Installation

IMPORTANT: Do not use this furnace if any part has been under water. Immediately call a qualified person to inspect the furnace and to replace any part of the control system and gas control which has been under water.

1. Check to be sure you have all of your tools.
2. Dispose of all packaging materials.
3. Check the furnace in its final location. Be sure the vent is not blocked.

Measure Temperature Rise

1. After 20 minutes of heating operation, measure the furnace temperature rise. Take air temperature readings in both the return air ducts and the heated air ducts (about 6 ft from the furnace where they will not be affected by radiant heat) as shown.

NOTE: If more than one run of return or heated air ducts is used, air temperature measurements should be taken in each duct. These measurements can be converted to an average to obtain the temperature rise of the whole system.

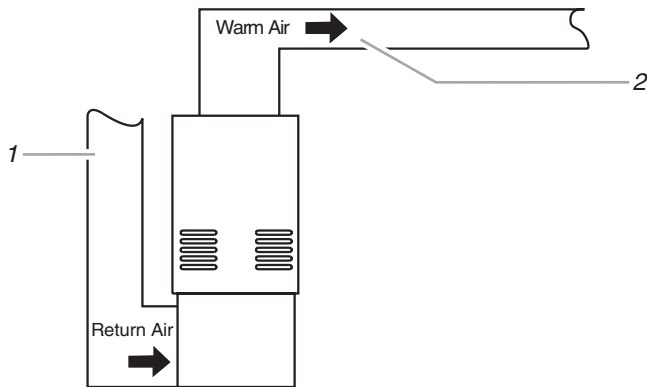

1. Measure return air here.
2. Measure supply temperature here.

2. If furnace doesn't maintain temperature rise within the range shown on the furnace rating plate, adjust the blower speed.

Adjust Blower Speed

⚠ WARNING



Electrical Shock Hazard

Disconnect power before servicing.

Replace all parts and panels before operating.

Failure to do so can result in death or electrical shock.

NOTE: See the Wiring Connection Diagram while performing the following procedure.

1. Disconnect power.
2. For heating speed, check the temperature rise and make the necessary adjustments to the blower speed tap. See Wiring Diagram.
3. Reconnect power.
4. Recheck the temperature rise. Repeat the procedure as necessary to achieve optimum temperature rise.
5. If the furnace does not begin to heat the room, see the "Troubleshooting" section.

Shut Down the Furnace

1. Set the room thermostat to the lowest setting.
2. Disconnect power.
3. Remove burner access door.
4. Shut off the gas by moving the gas control switch to the OFF position.
5. Replace the burner access door.

Sequence of Operation

Heating

A call for heat from the thermostat closes R to W on the blower control board, which begins the ignition sequence. The induced draft blower output energizes. The pressure switch senses normal combustion air flow and closes. After a 15-second pre-purge, the control energizes the hot surface igniter. After an igniter warm-up period, the main gas valve energizes. Upon main burner ignition, the circulating air blower energizes following a 30-second delay.

When the call for heat is satisfied, R to W opens and the gas to the burners shuts off. The control turns off the inducer after a 5-second post-purge delay and the heating speed blower output turns off following the blower “off” delay.

Fan On

A call for fan from the thermostat closes R to G on the control board. The control waits for a 1-second thermostat debounce delay before responding by energizing the heat speed blower. When the call for fan is turned off, the control de-energizes the heating speed blower after a 60-second delay.

Cooling

A call for cooling from the thermostat closes R to Y and R to G on the blower control board. The control waits for a 1-second thermostat debounce delay before energizing the cool speed blower. When the call for cooling is satisfied, the control de-energizes the cooling speed blower after a 60-second delay.

Controls

Pressure Switch

The pressure switch is a normally open switch that monitors combustion airflow. Inadequate airflow resulting from excessive venting system restriction or a failed combustion blower will cause the switch to remain open.

Rollout Switch(es)

The rollout switch(es) are normally closed switch(es) that open when abnormal temperatures exist in the burner area. This can be caused by a restricted heat exchanger causing main burner flame to “roll out” into the vestibule area or burner box.

The rollout switch(es) must be manually reset by pushing the button on top to restore furnace operation.

Primary Limit Control

This is a normally closed control that opens if abnormally high circulating air temperatures occur. It is an automatic reset control.

Auxiliary Limit Control (on some models)

This is a normally closed control, located on the circulating air blower housing, that opens under abnormal “reverse air flow” conditions that could occur in a counterflow or horizontal installation if the circulating air blower fails. It is an automatic reset control.

Safety Interlock Switch

When the blower door is removed, the safety interlock switch breaks the power supply to the burner controls and blower motor.

Blower Control Board

⚠ WARNING



Electrical Shock Hazard

Disconnect power before servicing.

Replace all parts and panels before operating.

Failure to do so can result in death or electrical shock.

The blower control board operates the circulating air blower, the combustion blower and any accessories connected to it.

WGFDC and WGFUD models

Feature user-selectable blower “off” delay times (60, 90, 120, and 150 seconds) that are factory set to provide a 120-second blower “off” delay on heating.

WFCU and WFCC models

Feature a fixed blower “off” delay of 90 seconds which is one-time adjustable to 150 seconds. See the “Wiring Connection” diagram.

In the event the limit control senses an abnormally high temperature and opens, the ignition control de-energizes, and the combustion blower and circulating air blower heating speed continue to energize.

Gas Control Valve

The gas control valve contains control logic to sense proper operating conditions and provides gas flow and ignition only when all conditions are properly met. The gas control valve also regulates the manifold gas pressure.

TROUBLESHOOTING

Furnace Fails to Operate Properly

Review “Sequence of Operation” and visually inspect the following before troubleshooting:

Is the power to the furnace on?

Is the blower compartment door securely closed?

Are the manual shutoff valves in the gas line to the furnace open?

Failure Codes

The system has a built-in, self-diagnostic capability. The control continuously monitors its own operation and the operation of the system. If a system problem occurs, a failure code is indicated by the LED on the gas control valve. See the Failure Codes chart for a description of the flash codes.

IMPORTANT: Do not remove the blower compartment door or turn off the power to the furnace because either action will clear the control’s memory of the failure.

1. Start the system by setting the thermostat above the room temperature.
2. Observe the system’s response.
3. Use the information provided in this section to check the system’s operation.

Failure Codes

LED Status (Flash Codes)	Fault Description
Off	No Power to the System Control
Steady Flash (11 or more flashes without a pause)	Normal Operation (Standby or call for heat)
2 Flashes	Pressure switch closed when it should be open
3 Flashes	Pressure switch stuck open 30 seconds or longer after call for heat (system in 5-minute delay mode before next call for heat). On/off switch in OFF position during a call for heat will generate this code.
4 Flashes	Open Limit Switch or Limit Switch Circuit
5 Flashes	Flame Sense Signal sensed out of proper sequence
*6 Flashes pause 1 Flash	Soft Lockout Type 1 Failure to light within 4 trials for ignition (See Note 1)
*6 Flashes pause 2 Flashes	Soft Lockout Type 2 Flame sense lost during run (See Notes 1 & 2)
*6 Flashes pause 3 Flashes	Soft Lockout Type 3 Pressure switch opened during run (See Notes 1 & 2)
*6 Flashes pause 4 Flashes	Soft Lockout Type 4 Limit or limit circuit opened during run (See Notes 1 & 2)
*6 Flashes pause 5 Flashes	Soft Lockout Type 5 Flame has gone away after Error Code 5 (See Note 1)
*6 Flashes pause 7 Flashes	Soft Lockout Type 7 Self-check failure (See Note 1)
*10 Flashes	Line Input Voltage Polarity Reversed

*On some models

Note 1: The 6 + X designation indicates a combination of flash codes. Six flashes shows the control is in soft lock-out, followed by X flashes to indicate the reason the control went into soft lockout. When the 6 + X code is flashed, the control will attempt a new ignition sequence after 1 hour (if the call for heat is still present). Reset of the thermostat will initiate a new ignition sequence immediately.

Note 2: Any combination of 5 “abnormal events” during a single call for heat will result in a soft lockout. An abnormal event is an occurrence of any of the following: flame sense failure during run, airflow proving circuit open during run, or limit circuit open during run. The flash code will indicate which was the last abnormal event that put the system into the soft lockout state (see above).

Wiring Connection Diagram - Honeywell® SmartValve II® Ignition System

	LINE VOLTAGE - FACTORY
	LINE VOLTAGE - FIELD
	LOW VOLTAGE - FACTORY
	LOW VOLTAGE - FIELD

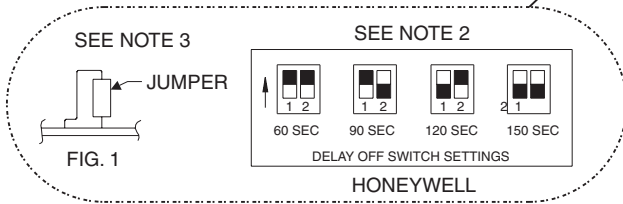
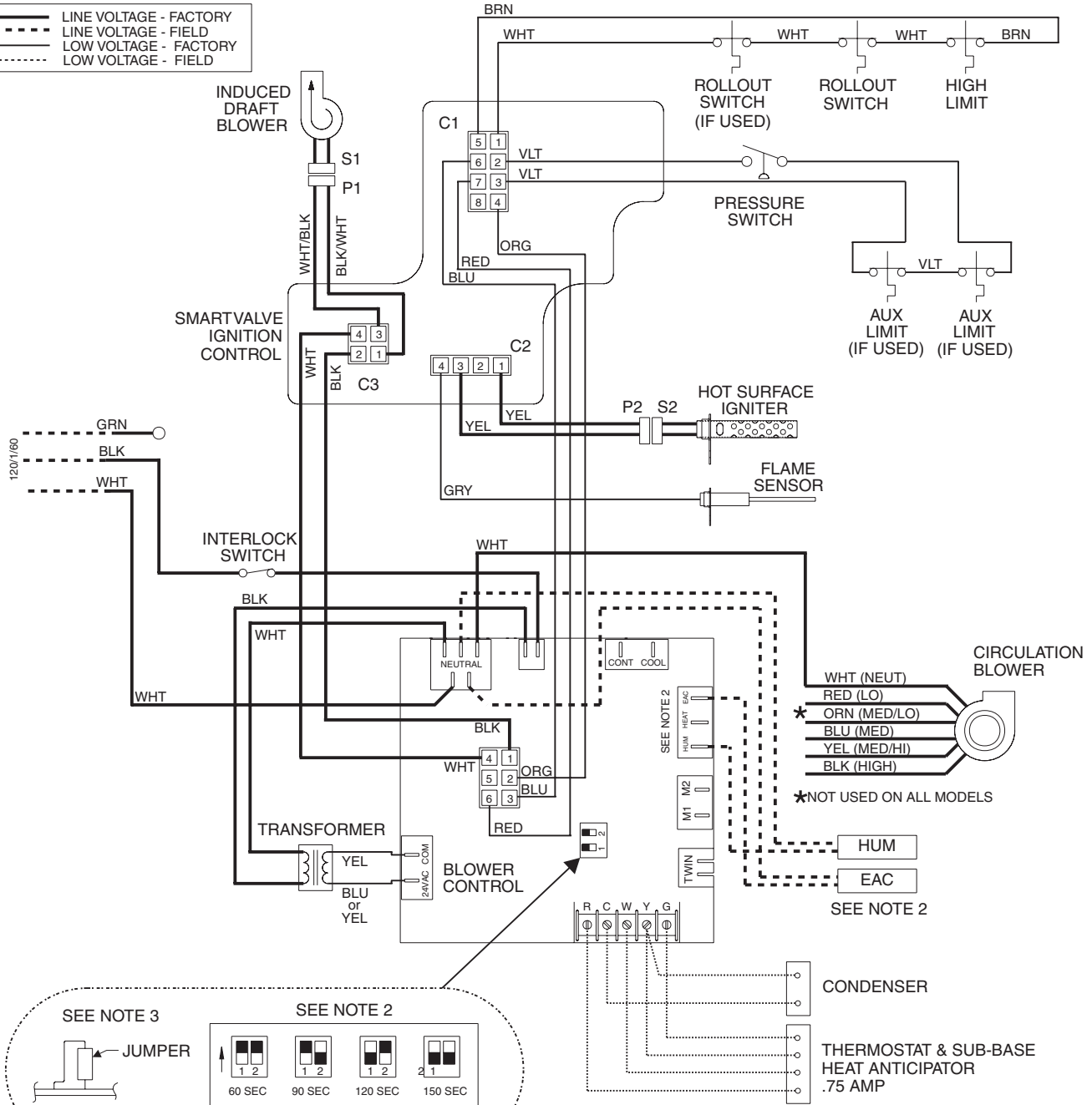

NOTES:

1. If any of the original wire as supplied with the furnace must be replaced, it must be replaced with wiring material having a temperature rating of at least 90°C.
2. Not used on all models
3. For a fixed blower off delay of 90 seconds see "Blower Control Board" section. Jumper can be cut for a 150 second off delay.

⚠ **WARNING**

Electrical Shock Hazard

Disconnect power before servicing.

Replace all parts and panels before operating.

Failure to do so can result in death or electrical shock.

Check codes for proper wiring and circuit protection before installation.

Wiring Schematic - Honeywell® SmartValve II® Ignition System

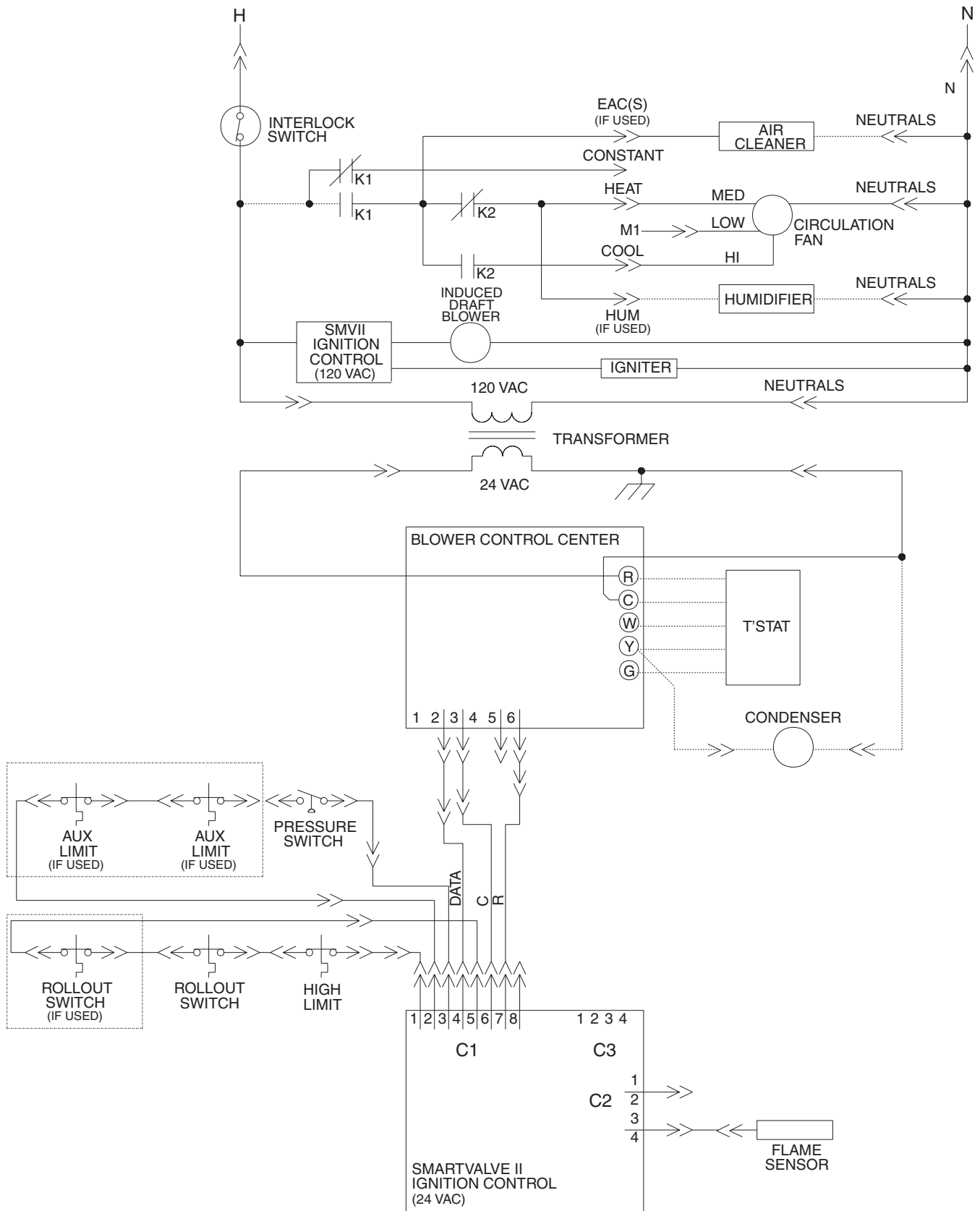

ASSISTANCE OR SERVICE

If you need further assistance, you can write to the below address with any questions or concerns:

Whirlpool® Home Cooling and Heating
7901 S.W. 6th Court
Plantation, Florida 33324

Please include a daytime phone number in your correspondence.

Accessories

To order accessories ask for the appropriate part number listed below or contact your Whirlpool® Home Cooling and Heating dealer.

ALPKT572-2	Natural Gas to Propane Conversion Kit
ALPKT574-2	Natural Gas to Propane Conversion Kit
WAFILTHA7-2	Filter Frame Kit
AFILT524-1	Side Return Filter Kit
AFILT529-1	Bottom Return Filter Kit
WABASE512	Combustible Floor Base (17.5" cabinets)
WABASE568	Combustible Floor Base (21.0" cabinets)
WABASE569	Combustible Floor Base (24.5" cabinets)
