

80UHG series units are mid-efficiency gas furnaces used for upflow or horizontal applications only, manufactured with tubular heat exchangers formed of aluminized steel. 80UHG units are available in heating capacities of 45,000 to 120,000 Btuh and cooling applications up to 5 tons. Refer to Engineering Handbook for proper sizing.

Units are factory equipped for use with natural gas. Kits are available for conversion to LPG operation. 80UHG-1 model units use electronic (direct spark) ignition. 80UHG-2 and -3 model units are equipped with the Lennox SureLight silicon nitride ignition system. The 80UHGX unit meets the California Nitrogen Oxides (NO_x) Standards and California Seasonal Efficiency requirements. All units use a redundant gas valve to assure safety shut-off as required by A.G.A. or C.G.A. Units may be installed in upflow or horizontal position.

All specifications in this manual are subject to change. Procedures outlined in this manual are presented as a recommendation only and do not supersede or replace local or state codes. In the absence of local or state codes, the guidelines and procedures outlined in this manual (except where noted) are recommended only and do not constitute code.

TABLE OF CONTENTS

Introduction	1
Specifications	2
Blower Data	3-4
High Altitude	4
Parts Identification	5-6
I Unit Components	6-15
II Installation	15
III Start Up	15
IV Heating System Service Checks	16-17
V Typical Operating Characteristics	18
VI Maintenance	19-20
VII Wiring and Sequence of Operation	21-28
VIII SureLight Troubleshooting Guide	29-34



SPECIFICATIONS

Model No.	80UHG2(X)-45	80UHG2(X)-60	80UHG3(X)-60	80UHG2(X)-75	80UHG3(X)-75	80UHG4(X)-75
Input Btuh (kW)	45,000 (13.2)	60,000 (17.6)		75,000 (22.0)		
Output Btuh (kW)	36,900 (10.8)	49,200 (14.4)		61,700 (18.1)		61,700 (18.1)
<input type="checkbox"/> A.F.U.E.	80.1%	80.5%		80.1%	80.0%	
California Seasonal Efficiency	75.4%	76.4%	75.9%	76.8%	76.8%	76.3%
Flue size connection diameter — in. (mm) round	3 (76)			4 (102)		
Temperature rise range — °F (°C)	30 - 60 (17 - 33)		45 - 75 (25 - 42)			
High static cert. by A.G.A./C.G.A. — in wg. (Pa)	.50 (125)					
Gas Piping Size I.P.S. Natural or LPG/propane	1/2 (13)					
Blower wheel nominal diameter x width	in.	9 x 7	10 x 7	9 x 7	10 x 7	12 x 8
	mm	229 x 178	254 x 178	229 x 178	254 x 178	305 x 203
Blower motor output — hp (W)	1/4 (187)		1/3 (224)	1/4 (187)	1/3 (224)	1/2 (373)
Nominal cooling that can be added	Tons	1, 1-1/2 or 2	2, 2-1/2 or 3	1, 1-1/2 or 2	2, 2-1/2 or 3	2, 2-1/2, 3, 3-1/2 or 4
	kW	3.5, 5.3 or 7.0	7.0, 8.8 or 10.6	3.5, 5.3 or 7.0	7.0, 8.8 or 10.6	7.0, 8.8, 10.6, 12.3 or 14.1
Shipping weight — lbs. (kg) 1 package	130 (59)		135 (61)			140 (64)
Electrical Characteristics	120 volts — 60 hertz — 1 phase (less than 12 amps) All models					
Optional Accessories (Must Be Ordered Extra)						
LPG/propane kit	LB-69845L (38K84)					
Twinning Kit	15L38 - 11lbs. (5 kg)					
Up-Flow/Horizontal Filter and Filter Rack Kits <input checked="" type="checkbox"/> No. & size of filters - in. (mm)	Single (32J02) Ten Pack (66K64) (1) 16 x 20 x 1 (406 x 508 x 25)					
Sidewall Power Venting Kit	79J15 — 25 lbs. (11 kg)					
Hanging Bracket Kit	LB-69957 (46J66) — 15 lbs. (8 kg)					

SPECIFICATIONS

Model No.	80UHG3/4(X)-100	80UHG4/5(X)-100	80UHG3/4(X)-120	80UHG4/5(X)-120	
Input Btuh (kW)	100,000 (29.3)		120,000 (35.2)		
Output Btuh (kW)	82,000 (24.0)		98,400 (28.8)		
<input type="checkbox"/> A.F.U.E.	80.1%	80.0%	80.0%	80.1%	
California Seasonal Efficiency	76.5%	77.0%	Not Available	75.5%	
Flue size connection diameter — in. (mm) round	4 (102)				
Temperature rise range — °F (°C)	45 - 75 (25 - 42)	35 - 65 (19 - 36)	45 - 75 (25 - 42)		
High static certified by A.G.A./C.G.A. — in wg. (Pa)	.50 (125)	.65 (162)	.50 (125)		
Gas Piping Size I.P.S. Natural or LPG/propane	1/2 (13)				
Blower wheel nominal diameter x width	in.	12 x 8	12 x 9	12 x 8	12 x 9
	mm	305 x 203	305 x 229	305 x 203	305 x 229
Blower motor output — hp (W)	1/2 (373)	3/4 (560)	1/2 (373)	3/4 (560)	
Nominal cooling that can be added	Tons	2, 2-1/2, 3, 3-1/2 or 4	3-1/2, 4, 5 or 6	2, 2-1/2, 3, 3-1/2 or 4	3-1/2, 4, 5 or 6
	kW	7.0, 8.8, 10.6, 12.3 or 14.1	12.3, 14.1, 17.6 or 21.1	7.0, 8.8, 10.6, 12.3 or 14.1	12.3, 14.1, 17.6 or 21.1
Shipping weight — lbs. (kg) 1 package	175 (79)				
Electrical Characteristics	120 volts — 60 hertz — 1 phase (less than 12 amps) All models				
Optional Accessories (Must Be Ordered Extra)					
LPG/propane kit	LB-69845K (81J14)				
Twinning Kit	15L38 (5 kg)				
Up-Flow/Horizontal Filter and Filter Rack Kits <input checked="" type="checkbox"/> No. & size of filters - in. (mm)	Single (46J14) Ten Pack (66K65) (1) 20 x 20 x 1 (508 x 508 x 25)				
Sidewall Power Venting Kit	79J15 — 25 lbs. (11 kg)				
Hanging Bracket Kit	LB-69957 (46J66) — 15 lbs. (8 kg)				

Annual Fuel Utilization Efficiency based on U.S. DOE test procedures and according to FTC labeling regulations. Isolated combustion system rating for non-weatherized furnaces.
 Polyurethane frame type filter is furnished with kit.

BLOWER DATA

80UHG2-45, 80UHG2-60 AND 80UHG2-75 BLOWER PERFORMANCE

External Static Pressure		Air Volume at Various Blower Speeds							
		High		Medium-High		Medium-Low		Low	
in. w.g.	Pa	cfm	L/s	cfm	L/s	cfm	L/s	cfm	L/s
0	0	1270	600	980	460	770	365	570	270
.05	12	1245	590	975	460	770	365	565	265
.10	25	1220	575	975	460	770	365	565	265
.15	37	1195	565	965	455	765	360	560	265
.20	50	1170	550	960	455	760	360	560	265
.25	62	1140	540	950	450	760	360	555	260
.30	75	1110	525	940	445	760	360	550	260
.40	100	1060	500	910	430	750	355	545	255
.50	125	990	465	880	415	740	350	540	255
.60	150	900	425	810	380	690	325	530	250
.70	175	800	380	740	350	630	295	520	245

NOTE — All air data is measured external to unit with 1 in. (25 mm) cleanable filter (not furnished) in place. Also see Filter Air Resistance table

80UHG3-60 AND 80UHG3-75 BLOWER PERFORMANCE

External Static Pressure		Air Volume at Various Blower Speeds							
		High		Medium-High		Medium-Low		Low	
in. w.g.	Pa	cfm	L/s	cfm	L/s	cfm	L/s	cfm	L/s
0	0	1425	670	1240	585	1000	470	800	380
.05	12	1415	670	1230	580	995	470	800	380
.10	25	1400	660	1220	575	990	465	795	375
.15	37	1385	655	1200	565	985	465	795	375
.20	50	1370	645	1180	555	980	460	790	375
.25	62	1350	635	1160	545	970	460	780	370
.30	75	1330	630	1140	540	955	450	770	365
.40	100	1280	605	1095	515	925	435	750	355
.50	125	1210	570	1040	490	900	425	720	340
.60	150	1135	535	985	465	860	405	680	320
.70	175	1070	505	920	435	800	380	630	300

NOTE — All air data is measured external to unit with 1 in. (25 mm) cleanable filter (not furnished) in place. Also see Filter Air Resistance table

80UHG4-75, 80UHG3/4-100 AND 80UHG3/4-120 BLOWER PERFORMANCE

External Static Pressure		Air Volume at Various Blower Speeds									
		High		Medium-High		Medium		Medium-Low		Low	
in. w.g.	Pa	cfm	L/s	cfm	L/s	cfm	L/s	cfm	L/s	cfm	L/s
0	0	1830	865	1600	755	1325	625	1070	505	880	415
.05	12	1815	855	1585	750	1320	625	1070	505	880	415
.10	25	1800	850	1570	740	1315	620	1070	505	880	415
.15	37	1875	885	1550	730	1310	620	1065	505	875	415
.20	50	1750	825	1530	720	1300	615	1060	500	875	415
.25	62	1725	815	1515	715	1290	610	1050	495	870	410
.30	75	1700	800	1500	710	1275	600	1040	490	870	410
.40	100	1650	780	1460	690	1245	590	1020	480	860	405
.50	125	1600	755	1420	670	1210	570	1000	470	840	395
.60	150	1550	730	1380	650	1170	550	980	460	820	385
.70	175	1480	700	1330	630	1130	535	960	455	790	375

NOTE — All air data is measured external to unit with 1 in. (25 mm) cleanable filter (not furnished) in place. Also see Filter Air Resistance table

BLOWER DATA

80UHG4/5-100 AND 80UHG4/5-120 BLOWER PERFORMANCE

External Static Pressure		Air Volume at Various Blower Speeds									
		High		Medium-High		Medium		Medium-Low		Low	
in. w.g.	Pa	cfm	L/s	cfm	L/s	cfm	L/s	cfm	L/s	cfm	L/s
0	0	2450	1155	2160	1020	1970	930	1700	800	1500	710
.05	12	2440	1150	2155	1015	1965	925	1695	800	1500	710
.10	25	2430	1145	2150	1015	1960	925	1690	800	1495	705
.15	37	2415	1140	2135	1010	1950	920	1685	795	1495	705
.20	50	2400	1135	2120	1000	1940	915	1680	795	1490	705
.25	62	2380	1125	2105	995	1930	910	1675	790	1480	700
.30	75	2360	1115	2090	985	1915	905	1670	790	1470	695
.40	100	2310	1090	2050	965	1870	880	1650	780	1440	680
.50	125	2260	1065	2000	945	1810	855	1610	760	1410	665
.60	150	2180	1030	1950	920	1750	825	1560	735	1370	645
.70	175	2100	990	1890	890	1700	800	1520	715	1330	630

NOTE — All air data is measured external to unit with 1 in. (25 mm) cleanable filter (not furnished) in place. Also see Filter Air Resistance table

FILTER AIR RESISTANCE

cfm (L/s)	in. w.g. (Pa)
0 (0)	0.00 (0)
200 (95)	0.01 (2)
400 (185)	0.03 (7)
600 (280)	0.04 (10)
800 (375)	0.06 (15)
1000 (470)	0.09 (22)
1200 (560)	0.12 (30)
1400 (655)	0.15 (37)
1600 (750)	0.19 (47)
1800 (845)	0.23 (57)
2000 (935)	0.27 (67)
2200 (1030)	0.33 (82)
2400 (1125)	0.38 (95)
2600 (1220)	0.44 (110)

HIGH ALTITUDE DERATE

Refer to table below for manifold pressure settings for installations at different altitudes and different fuels.

NOTE-In Canada, certification for installations over 4500 ft. (1372m) above sea level is the jurisdiction of the local authorities.

The combustion air inducer prove switches are factory set and are not to be adjusted.

At elevations of 4500 ft. (1372m) or greater, change factory installed pressure switch to switch listed in table below.

Manifold Absolute Pressure in. w.c. (kPa)

ALTITUDE ft. (m)				
FUEL	0-4500 (0-1372)	4500-5500 (1372-1676)	5500-6500 (1676-1981)	6500-7500 (1982-2286)
NAT	3.5 (0.87)	3.4 (0.85)	3.3 (0.82)	3.2 (0.80)
LP	9.5 (2.36)	9.2 (2.29)	8.9 (2.21)	8.6 (2.14)

UNIT MODEL	PRESSURE SWITCH PART NUMBER
80UHG-45	NO CHANGE
80UHG-60	NO CHANGE
80UHG-75	88J8001
80UHG-100	18L2401
80UHG-120	18L2401

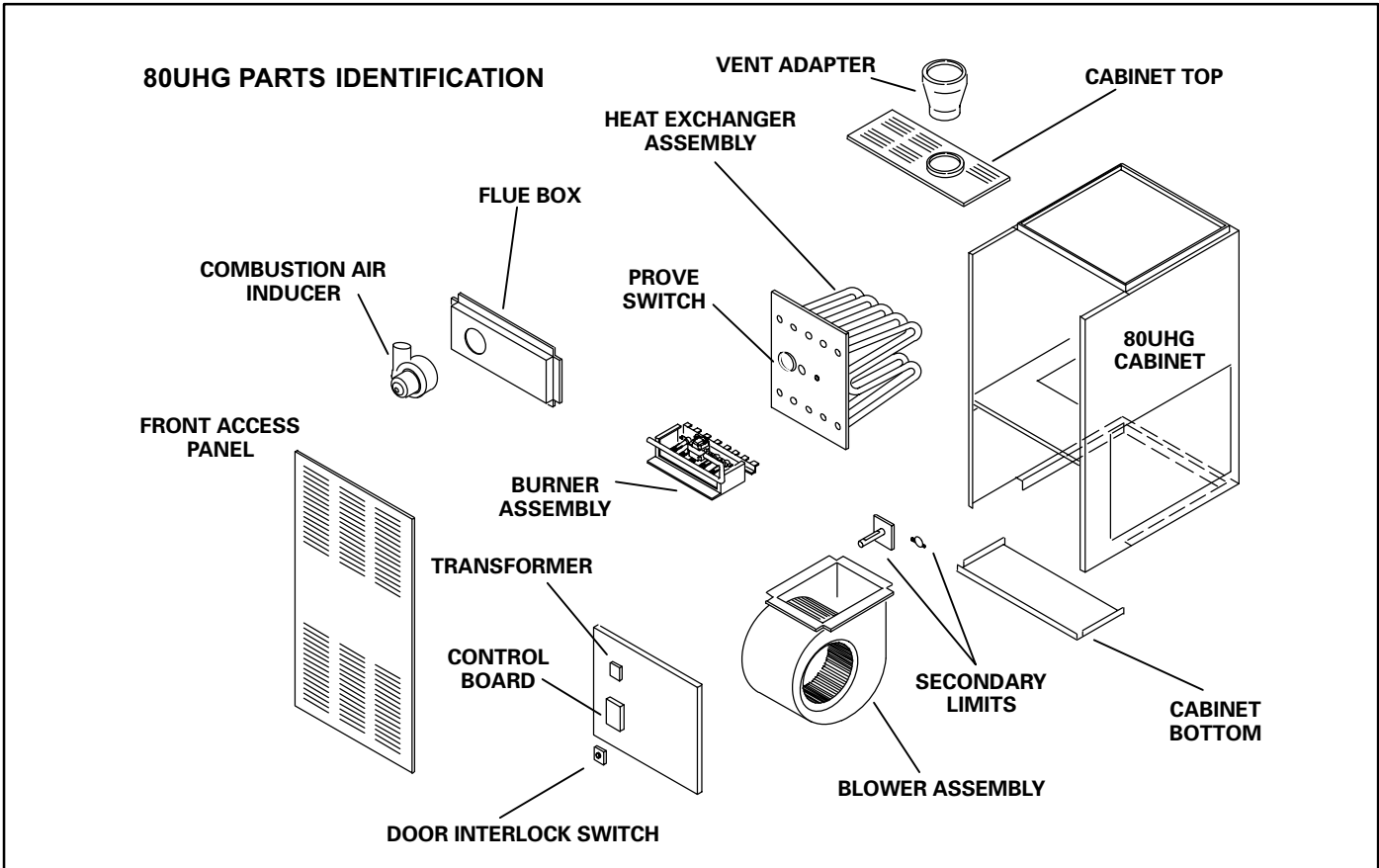

FIGURE 1

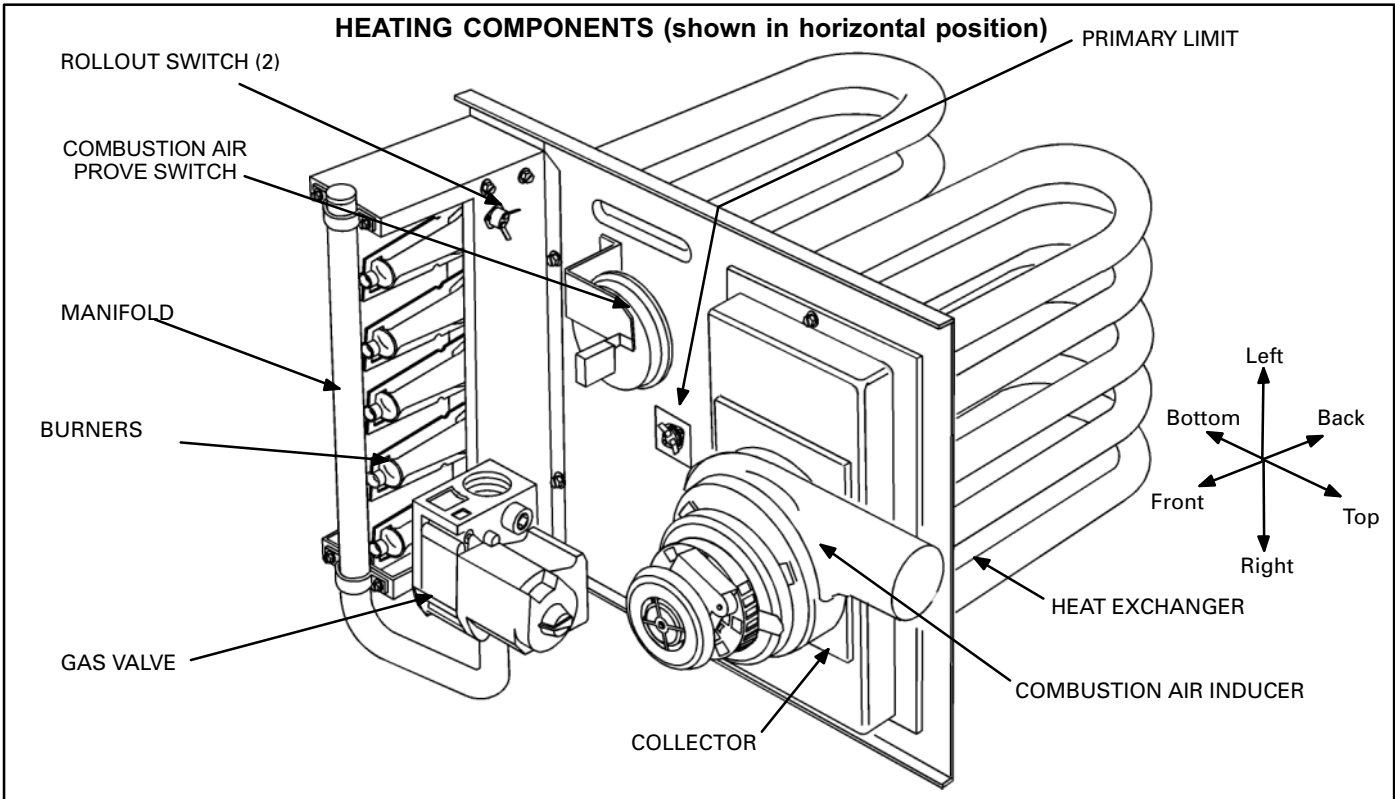

FIGURE 2

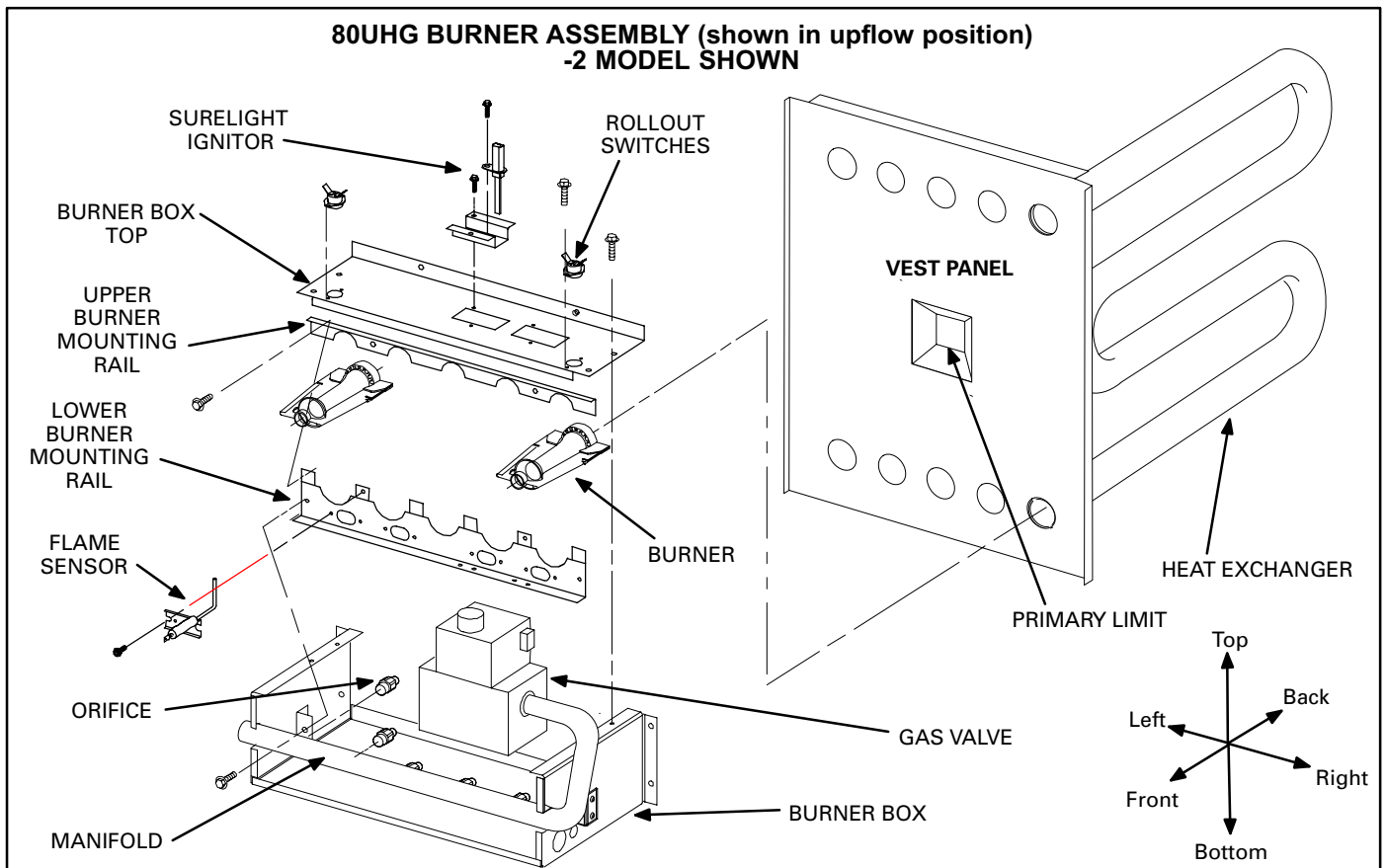

FIGURE 3

I-UNIT COMPONENTS (Figures 1, 2, 3)

80UHG unit components are shown in figure 1. The gas valve, combustion air inducer and burners can be accessed by removing the burner access panel. Electrical components are mounted to the blower housing. 80UHG units are factory equipped with bottom return air panels in place. The panels are designed to be field removed as required for bottom air return. Knockout panels are provided for side return air.

ELECTROSTATIC DISCHARGE (ESD)

Precautions and Procedures

⚠ CAUTION

Electrostatic discharge can affect electronic components. Take precautions during furnace installation and service to protect the furnace's electronic controls. Precautions will help to avoid control exposure to electrostatic discharge by putting the furnace, the control and the technician at the same electrostatic potential. Neutralize electrostatic charge by touching hand and all tools on an unpainted unit surface, such as the gas valve or blower deck, before performing any service procedure.

1- Control Transformer (T1)

A transformer located on the blower housing provides power to the low voltage section of the unit. Transformers on all models are rated 30VA with a 120V primary and a 24V secondary.

2-Door Interlock Switch (S51)

A door interlock switch rated 16A at 125VAC is wired in series with line voltage. When the blower door is removed the unit will shut down.

⚠ DANGER

Shock hazard.
Spark related components contain high voltage. Disconnect power before servicing. Control is not field repairable. If control is inoperable, simply replace entire control.
Can cause injury or death. Unsafe operation will result if repair is attempted.

3- Furnace Control (A3) 80UHG-2, -3 Models

80UHG-2 and -3 model units are equipped with the Lennox SureLight ignition system. The system consists of ignition control board (figure 6 with control terminal designations in table 4) and ignitor (figure 7). The board and ignitor work in combination to ensure furnace ignition and ignitor durability. The SureLight integrated board controls all major furnace operations. The board also features two LED lights for troubleshooting and two accessory terminals rated at (4) four amps. See table 3 for troubleshooting diagnostic codes. Table 1 and 2 show jack plug terminal designations. Units equipped with the SureLight board can be used with either electronic or electro-mechanical thermostats without modification. The SureLight ignitor is made of durable silicon-nitride. Ignitor longevity is also enhanced by voltage ramping by the control board. The board finds the lowest ignitor temperature which will successfully light the burner, thus increasing the life of the ignitor. Each time power is applied to the furnace, the SureLight board performs a selfcheck including energizing the combustion air blower for a period of 1 second.

TABLE 1

SureLight BOARD J156 (J2) TERMINAL DESIGNATIONS	
PIN #	FUNCTION
1	Combustion Air Inducer Line
2	Ignitor Line
3	Combustion Air Inducer Neutral
4	Ignitor Neutral

TABLE 2

SureLight BOARD J58 (J1) TERMINAL DESIGNATIONS	
PIN #	FUNCTION
1	Primary Limit / Pressure Switch Out
2	Secondary Limit
3	24V
4	Not Used
5	Rollout Switch In
6	24V
7	Primary Limit In
8	Ground
9	Gas Valve In
10	Pressure Switch In
11	Rollout Switch Out
12	Gas Valve Out

a-Electronic Ignition (See Figure 5)

On a call for heat the SureLight control monitors the combustion air inducer pressure switch. The control will not begin the heating cycle if the prove switch is closed (bypassed). Once the prove switch is determined to be open, the combustion air inducer is energized. When the differential in the prove switch is great enough, the prove switch closes and a 15-second pre-purge begins. If the prove switch is not proven within 2-1/2 minutes, the control goes into Watchguard-Pressure Switch mode for a 5-minute reset period.

After the 15-second pre-purge period, the SureLight ignitor warms up for 20 seconds during which the gas valve opens at 19 seconds for a 4-second trial for ignition. The ignitor stays energized for the first second of the 4-second trial. 80UHG units equipped with control 10M9301: ignitor remains energized during the 4 second trial until flame is sensed. If ignition is not proved during the 4-second period, the control will try four more times with an inter purge and warm-up time between trials of 35 seconds. After a total of five trials for ignition (including the initial trial), the control goes into Watchguard-Flame Failure mode. After a 60-minute reset period, the control will begin the ignition sequence again.

The SureLight control board has an added feature that prolongs the life of the ignitor. After a successful ignition, the SureLight control utilizes less power to energize the ignitor on successive calls for heat. The control continues to ramp down the voltage to the ignitor until it finds the lowest amount of power that will provide a successful ignition. This amount of power is used for 255 cycles. On the 256th call for heat, the control will again ramp down until the lowest power is determined and the cycle begins again.

b-Fan Time Control

The fan on time of 45 seconds is not adjustable. Fan off time (time that the blower operates after the heat demand has been satisfied) can be adjusted by flipping the dip switches located on the SureLight integrated control. The unit is shipped with a factory fan off setting of 90 seconds. Fan off time will affect comfort and is adjustable to satisfy individual applications. See figure 4.

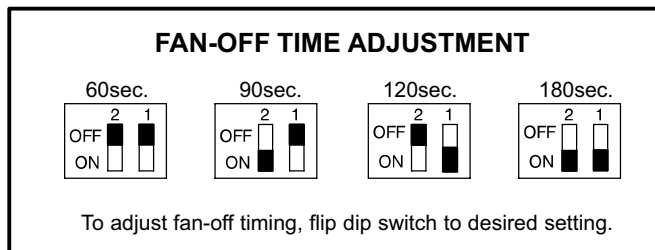

FIGURE 4

The SureLight board is equipped with two LED lights for troubleshooting. The diagnostic codes are listed below in table 3.

TABLE 3

DIAGNOSTIC CODES		
MAKE SURE TO ID LED'S CORRECTLY: REFER TO INSTALLATION INSTRUCTIONS FOR CONTROL BOARD LAYOUT.		
LED #1	LED #2	DESCRIPTION
SIMULTANEOUS SLOW FLASH	SIMULTANEOUS SLOW FLASH	Power - Normal operation Also signaled during cooling and continues fan.
SIMULTANEOUS FAST FLASH	SIMULTANEOUS FAST FLASH	Normal operation - signaled when heating demand initiated at thermostat.
SLOW FLASH	ON	Primary or Secondary limit open. Units with board 12L69: Limit must close within 5 trials for ignition or board goes into one hour limit Watchguard. Units with board 56L84: Limit must close within 3 minutes or board goes into one hour limit Watchguard.
OFF	SLOW FLASH	Pressure switch open or has opened 5 times during a single call for heat; OR: Blocked inlet/exhaust vent; OR: Condensate line blocked; OR: Pressure switch closed prior to activation of combustion air blower.
ALTERNATING SLOW FLASH	ALTERNATING SLOW FLASH	Watchguard - burners fail to ignite.
SLOW FLASH	OFF	Flame sensed without gas valve energized.
ON	SLOW FLASH	Rollout switch open. OR: 9 pin connector improperly attached.
ON ON OFF	ON OFF ON	Circuit board failure or control wired incorrectly.
FAST FLASH	SLOW FLASH	Main power polarity reversed. Switch line and neutral.
SLOW FLASH	FAST FLASH	Low flame signal. Measures below 0.2 microAmps. Replace flame sense rod.
ALTERNATING FAST FLASH	ALTERNATING FAST FLASH	Improper main ground or line voltage below 75 volts; OR: Broken ignitor; OR: Open ignitor circuit.

NOTE - Slow flash equals 1 Hz (one flash per second). Fast flash equals 3 Hz (three flashes per second). Drop out flame sense current < 0.15 microAmps

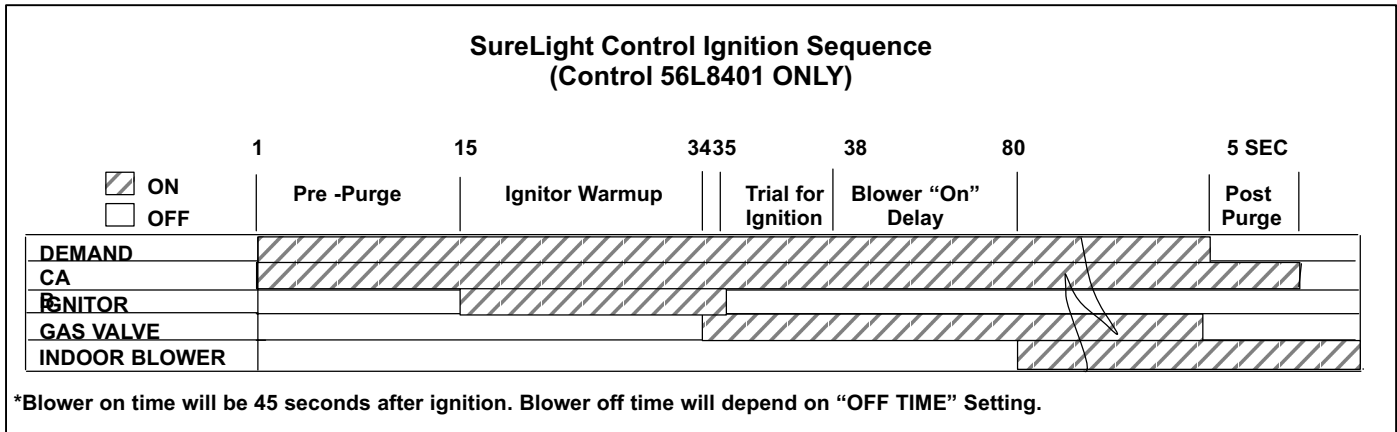

FIGURE 5

SURELIGHT INTEGRATED CONTROL BOARD

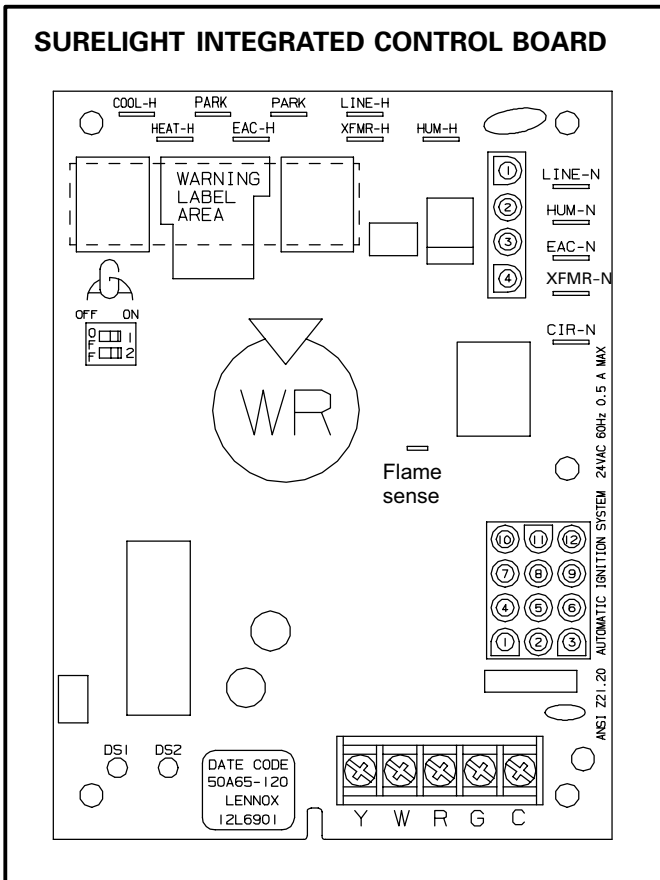

FIGURE 6

4-Flame Sensor 80UHG -2 models

A flame sensor is located on the left side of the burner support. See figure 8. The sensor is mounted on a bracket in the burner support and the tip protrudes into the flame envelope of the left-most burner. The sensor is fastened to burner supports and can be removed for service without removing any part of the burners. During operation, flame is sensed by current passed through the flame and sensing electrode. The SureLight control allows the gas valve to remain open as long as flame signal is sensed.

NOTE – The 80UHG furnace contains electronic components that are polarity sensitive. Make sure that the furnace is wired correctly and is properly grounded.

TABLE 4

TERMINAL DESIGNATIONS	
COOL-H	Blower - Cooling Speed (120VAC)
HEAT-H	Blower - Heating Speed (120VAC)
EAC-H	Electronic Air Cleaner (120VAC)
HUM-H	Humidifier (120VAC)
XFMR-H	Transformer (120VAC)
LINE-H	Input (120VAC)
LINE-N	Input (Neutral)
HUM-N	Humidifier (Neutral)
EAC-N	Electronic Air Cleaner (Neutral)
XFMR-N	Transformer (Neutral)
CIR-N	Not Used
PARK	
(FLAME SENSE)	

SureLight Ignitor

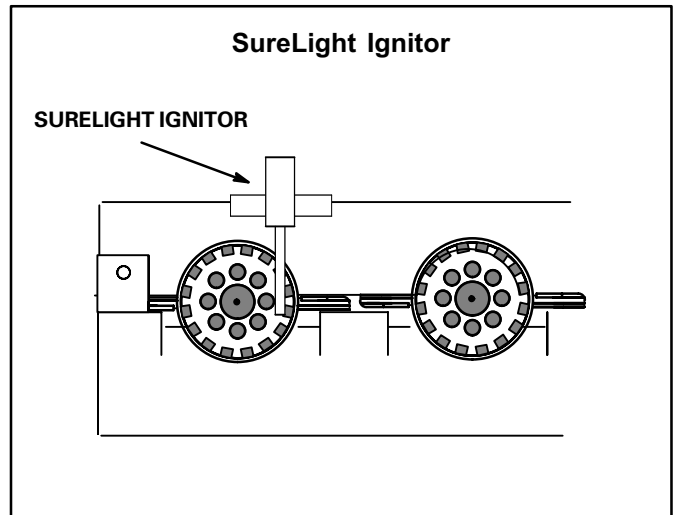

FIGURE 7

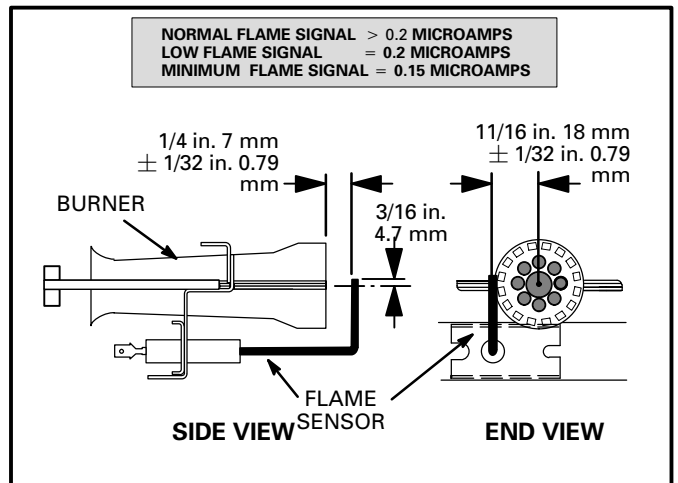

FIGURE 8

5- Furnace Control (A3) 80UHG-1 Model

80UHG units are equipped with an integrated ignition/blower control (EGC-2) which controls ignition, safety circuits, blower operation, fan off timing, and allows for thermostat connection and troubleshooting. The EGC-2 is a printed circuit board which is divided into two sections, 120 and 24VAC. Line voltage comes into the board on the 120VAC side. See figure 10. Terminal designations are listed in tables 6 and 7.

Ignition Control

80UHG units use the EGC-2 direct spark integrated ignition control. The EGC-2 controls and monitors the entire sequence of operation. On a call for heat from the thermostat the control monitors the combustion air inducer prove switch. The control will not begin the heating cycle if the prove switch is closed (by-passed). Once the prove switch is determined to be open, the combustion air inducer is energized. When the differential in pressure across the prove switch is great enough, the prove switch closes and a 15 second pre-purge period begins. If the prove switch does not close within 2 1/2 minutes, the control goes into 5 minute watchguard. After the pre-purge period, the gas valve will open and ignition (spark) will be attempted for 10 seconds. After ignition, the control initiates a ten second flame stabilization period. The flame stabilization period allows the burners to heat up and the flame to stabilize. Once flame is established, the control will constantly monitor the burner flame using flame rectification. Flame failure response time is 0.8 seconds.

If the initial attempt for ignition fails, the sequence is repeated up to five times. After the fifth trial, the control goes into "Watchguard"*. During watchguard mode, the entire unit will be de-energized for one hour. After one hour the control will repeat the ignition sequence. Watchguard may be manually reset by breaking and remaking thermostat demand.

*NOTE-If flame is established beyond the 10 second flame stabilization period then lost, the control resets for five more ignition trials. The control can be reset five times during one unsatisfied thermostat demand, providing a maximum of 25 trials for ignition.

Safety Circuits

During the entire heating demand the control monitors the safety circuits. If the primary or secondary heating limits open, the control de-energizes the main gas valve and combustion air blower while the indoor blower remains energized. When the limit automatically resets, the ignition sequence also resets. If either of the limits trip five consecutive times during one unsatisfied thermostat demand, the control will go into watchguard for one hour.

The control monitors main valve voltage. If voltage is sensed

when no voltage should be present, the control de-energizes the combustion air inducer which terminates voltage to the valve. The system goes into hard lock-out which is reset only by removing power to the unit.

If flame is sensed when no flame should be present, the control will energize the combustion and indoor blowers. The unit will remain locked in this sequence until the flame is no longer sensed or the main power is turned off to reset the control.

The roll-out circuit is also monitored by the EGC-2 control. If the switch opens, the control will de-energize the gas valve, combustion air inducer, and indoor blower. The unit will remain de-energized until the switch is manually reset.

⚠ DANGER

Shock hazard. Avoid personal injury. Make sure to disconnect power before changing fan "off" timing.

Blower Operation / Fan Off Timings

Fan "off" timing (time that the blower operates after the heat demand has been satisfied) can be adjusted by moving the jumper on the EGC-2 blower control board. Figure 9 shows the various fan "off" timings and how jumper should be positioned. To adjust fan "off" timing, gently disconnect jumper and reposition across pins corresponding with new timing. Unit is shipped with a factory fan "off" setting of 180 seconds. Fan "on" time is factory set at 45 seconds following the opening of the main gas valve and is not adjustable.

Fan "off" time will affect comfort and efficiency and is adjustable to satisfy individual applications. The fan "off" timing is initiated after a heating demand but not after a cooling demand.

NOTE—If fan "off" time is set too low, residual heat in heat exchanger may cause primary limit S10 to trip, resulting in frequent cycling of blower. If this occurs, adjust blower to longer fan "off" time setting.

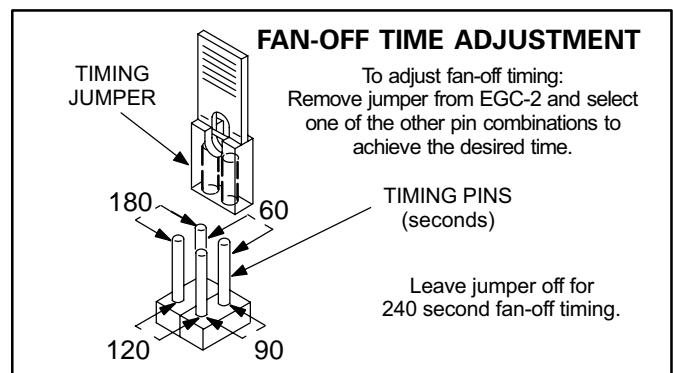

FIGURE 9

Thermostat Connection

Thermostat wires are connected to the terminal strip found on the EGC-2 control board.

Troubleshooting

The EGC-2 control board is equipped with two diagnostic green LEDs to indicate the mode of failure. The LED lights are marked DIAG #1 and DIAG #2. The codes are given in table 5.

A slotted edge connector is also provided for the Lennox Diagnostic Module (part number 11K75). See figure 10. When connected to the EGC-2 control board, the module displays (in words) the diagnostic condition.

TABLE 5

EGC-2 DIAGNOSTIC CODES		
DIAG #2	DIAG #1	Diagnostic Condition
Simultaneous Flash	Simultaneous Flash	Power "ON". Normal Operation. Increased flash rate indicates there is a heating demand.
On	Flash	Primary or Secondary Limit Switch Open. Auto-Reset Switch.
Flash	Off	Pressure Switch Watchguard, pressure switch opened during operation.
Alternate Flash	Alternate Flash	Watchguard, burners failed to ignite.
Off	Flash	Flame sensed without valve energized.
Flash	On	Roll-out Switch Open. Manual-Reset Switch.
Continuous On	Continuous On	Circuit board self-check failure or ignition/blower control is wired incorrectly.

80UHG-1 MODEL INTEGRATED CONTROL (EGC-2)
 (Shown as installed in horizontal left hand application)
 (See tables 6 and 3 for terminal designations)

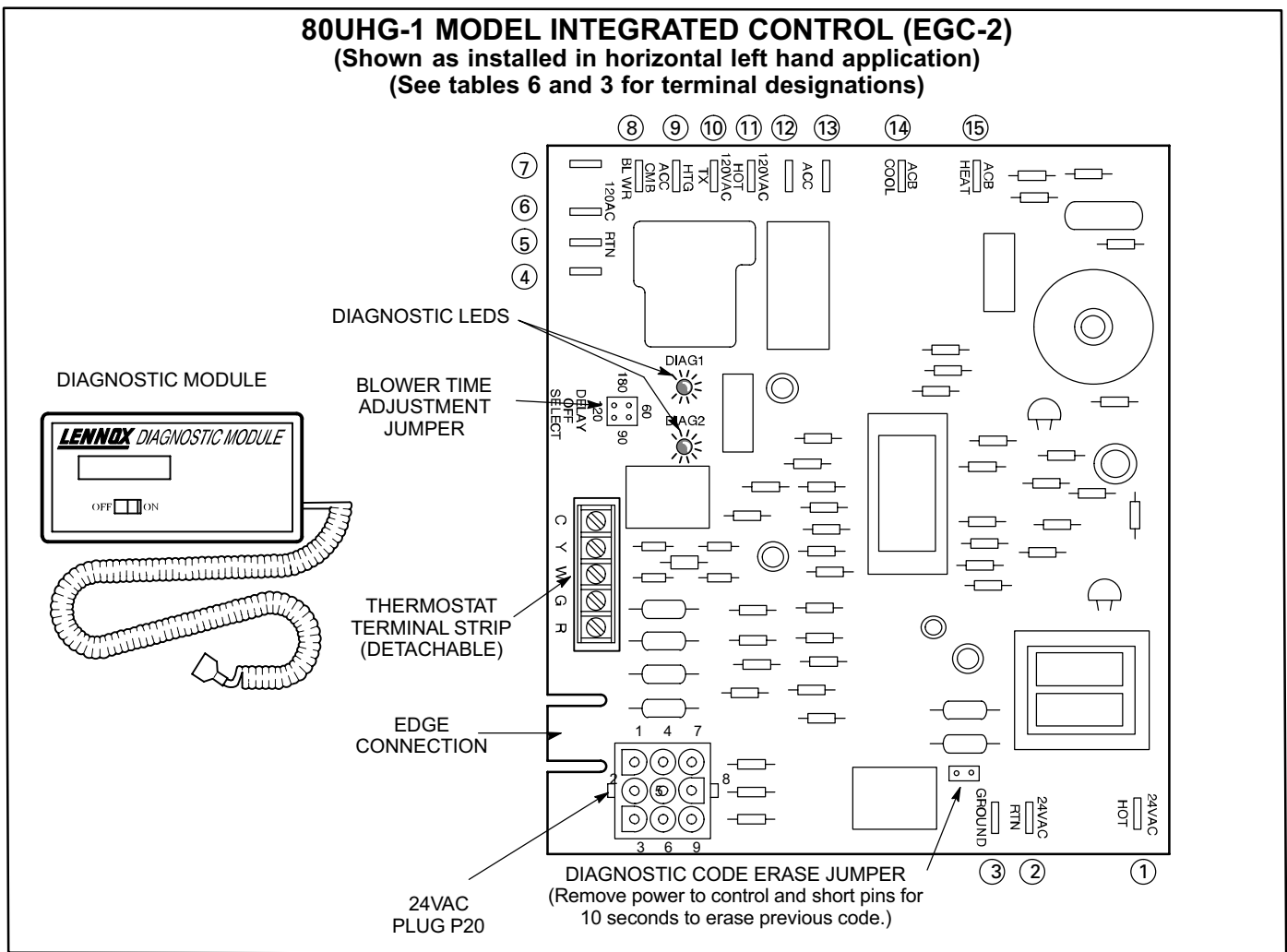

FIGURE 10

TABLE 6

BLOWER CONTROL A15 TERMINAL DESIGNATIONS		
Terminal Designation (See fig. 10)	Type	Function
R	Screw Strip	24VAC to Thermostat (Red)
G	Screw Strip	Manual Fan Input from Thermostat (Green)
W	Screw Strip	Heat Demand Input from Thermostat (White)
Y	Screw Strip	Cool Demand Input from Thermostat (Yellow)
C	Screw Strip	Common Ground to Thermostat
1	1/4" Spade	24VAC Hot from Transformer
2	1/4" Spade	24VAC Return to Transformer
3	1/4" Spade	24VAC Ground
4, 5, 6	1/4" Spade	120VAC Return - 120VAC Common
7	1/4" Spade	120VAC Return - 120VAC Common Input
8	1/4" Spade	Combustion Blower (Line Voltage)
9	1/4" Spade	Heat Only Accessory (Line Voltage)
10	1/4" Spade	120VAC Hot to Transformer
11	1/4" Spade	120VAC Hot Input
12, 13	1/4" Spade	Accessories (Line Voltage)
14	1/4" Spade	ACB Cool Speed (Line Voltage)
15	1/4" Spade	ACB Heat Speed (Line Voltage)

TABLE 7

EGC-2 CONTROL JACK/PLUG 20 TERMINAL DESIGNATIONS	
Pin #	Function
1	Rollout Switch Out
2	Spare
3	Gas Valve Common
4	Pressure Switch Return
5	Hi Limit Return / Pressure Switch Out
6	Flame Sensor
7	Gas Valve Out
8	High Limit Out
9	Rollout Switch Return

6-Blower Motors and Capacitors

All 80UHG units use direct drive blower motors. All motors used are 120V permanent split capacitor motors to ensure maximum efficiency. See table 8 for ratings.

TABLE 8

80UHG BLOWER RATINGS 120V 1PH		
BLOWER MOTOR	HP	CAP
80UHG2	1/4	5MFD 370V
80UHG3	1/3	5MFD 370V
80UHG3/4	1/2	7.5MFD 370V
80UHG4	1/2	7.5MFD 370V
80UHG4/5	3/4	40MFD 370V
80UHG5/6	3/4	40MFD 370V

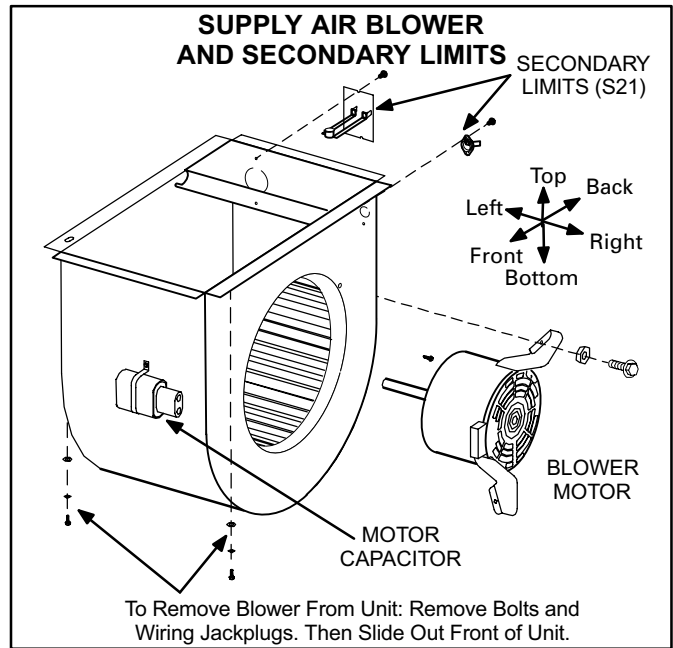

FIGURE 11

7-Combustion Air Inducer (B6)

All 80UHG units use a combustion air inducer to move air through the burners and heat exchanger during heating operation. The blower uses a 120VAC motor. The motor operates during all heating operation and is controlled by furnace control A3. The blower also operates for 15 seconds before burner ignition (pre-purge) and for 5 seconds after the gas valve closes (post-purge)

A proving switch connected to the combustion air inducer housing is used to prove combustion air inducer operation. The switch monitors air pressure in the blower housing. During normal operation, the pressure in the housing is negative. If pressure becomes less negative (signifying an obstruction) the prove switch opens. When the prove switch opens, the furnace control (A3) immediately closes the gas valve to prevent burner operation.

8-Flame Rollout Switches (S47)

Flame rollout switch is a high temperature limit located on top of the burner box. Each furnace is equipped with two identical switches. One switch is located over the leftmost burner and the other switch is located over the rightmost burner. The limit is a N.C. SPST manual-reset limit connected in series with the ignition control A3. When S47

senses rollout, the ignition control immediately stops ignition and closes the gas valve. If unit is running and flame rollout is detected, the gas valve will close and ignition control will be disabled. Rollout can be caused by a blocked flue or lack of combustion air. The switch is factory set and cannot be adjusted. The setpoint will be printed on the side of the limit. The switch can be manually reset. To manually reset a tripped switch, push the reset button located on the control.

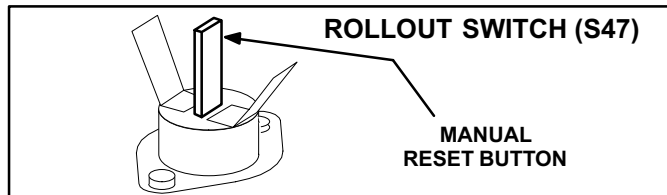

FIGURE 12

9-Primary Limit Control (S10)

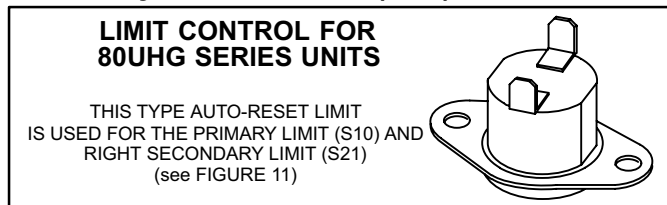

FIGURE 13

The primary limit (S10) on 80UHG units is located in the middle of the heating vestibule panel. When excess heat is sensed in the heat exchanger, the limit will open. If the limit is tripped, the furnace control energizes the supply air blower and closes the gas valve. The limit automatically resets when unit temperature returns to normal. The switch is factory set and cannot be adjusted. The switch may have a different setpoint for each unit model number. However, the setpoint will be printed on the side of the limit.

10-Secondary Limit Controls (S21)

The secondary limit (S21) on 80UHG units is located in the blower compartment in the back side of the blower housing. When excess heat is sensed in the blower compartment, the limit will open. If the limit is tripped, the furnace control energizes the supply air blower and closes the gas valve. The limit automatically resets when unit temperature returns to normal. The switch is factory set and cannot be adjusted. The setpoint will be printed on the limit.

Two limits are supplied in each furnace. 80UHG3, 80UHG4 and 80UHG4/5 model units built prior to April 1999, will have one each of style shown in figures 13 and 14. If stick limit (figure 14) suffers from nuisance trips on the above model units and the furnace is in the horizontal position, replace with limit kit no. 50L98. All 80UHG2 model units will have one of each style shown in figures 13 and 14.

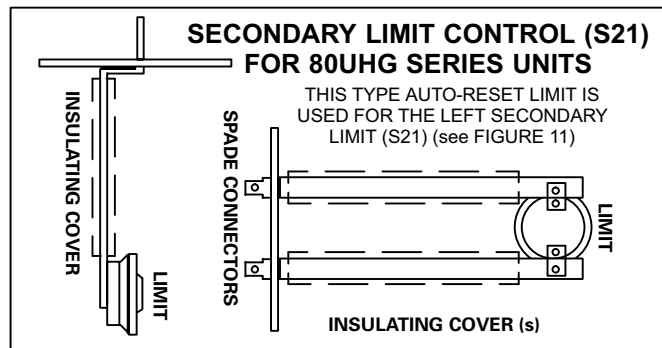

FIGURE 14

11-Spark Electrode and Flame Sensor 80UHG-1 Models

Figure 17 shows the arrangement of flame sensor, spark electrode and burners. The ignition control uses direct spark to ignite the rightmost burner and the burners cross-light to the left. The flame sensor uses flame rectification to sense combustion. A flame retention ring in the end of each burner is used to maintain correct flame length and shape and to keep the flame from lifting off the burner head.

Figure 18 shows the gap between tip of the electrodes and the burner surface, and the gap between the sensor and burner surface.

12-Gas Valve

The 80UHG uses a gas valve manufactured by Honeywell or White Rodgers. The valve is internally redundant to assure safety shut-off. If the gas valve must be replaced, the same type valve must be used.

24VAC terminals and gas control knob are located on top of the valve. All terminals on the gas valve are connected to wires from the electronic ignition control. 24V applied to the terminals energizes the valve.

Inlet and outlet pressure taps are located on the valve. A regulator adjustment screw (figures 15 and 16) is located on the valve.

LPG changeover kits are available from Lennox. Kits include burner orifices and a gas valve regulator conversion kit.

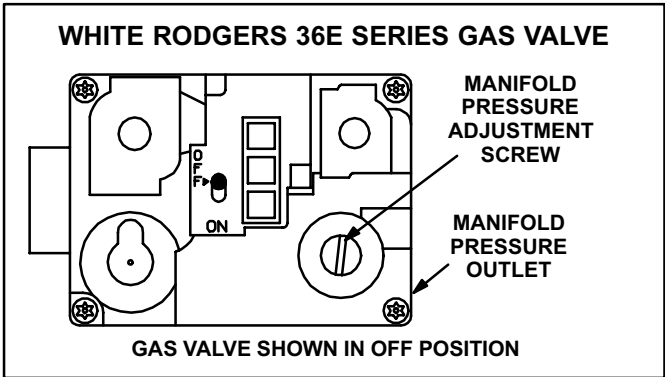

FIGURE 15

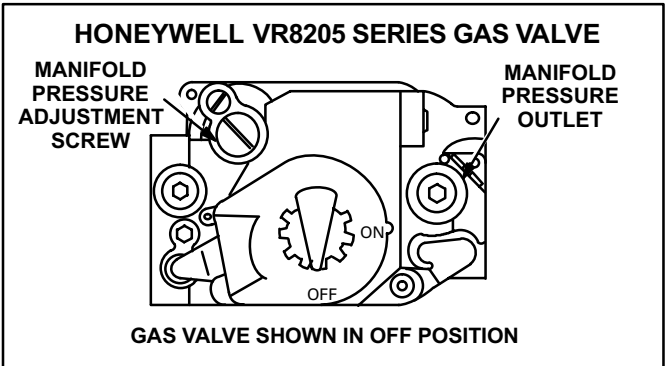

FIGURE 16

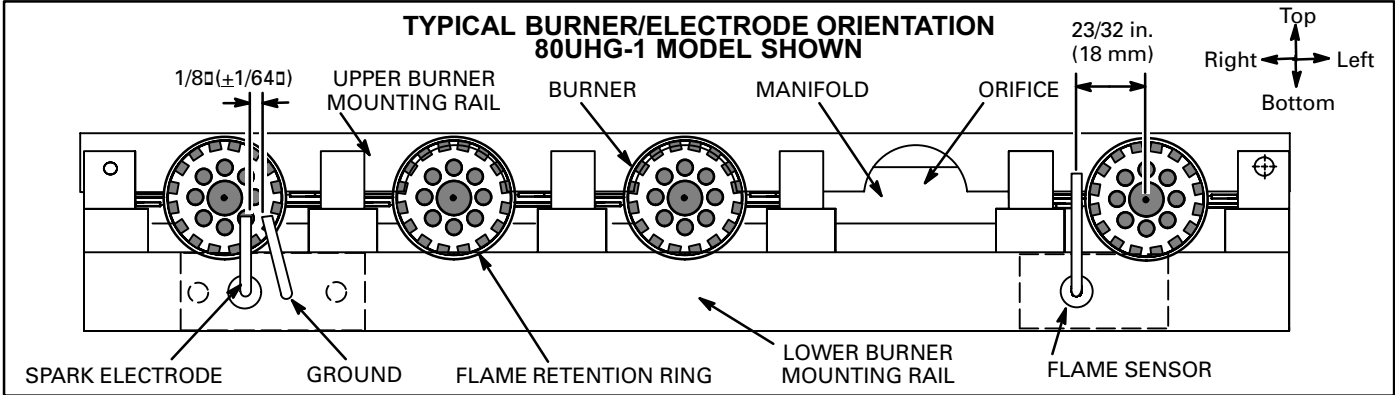

FIGURE 17

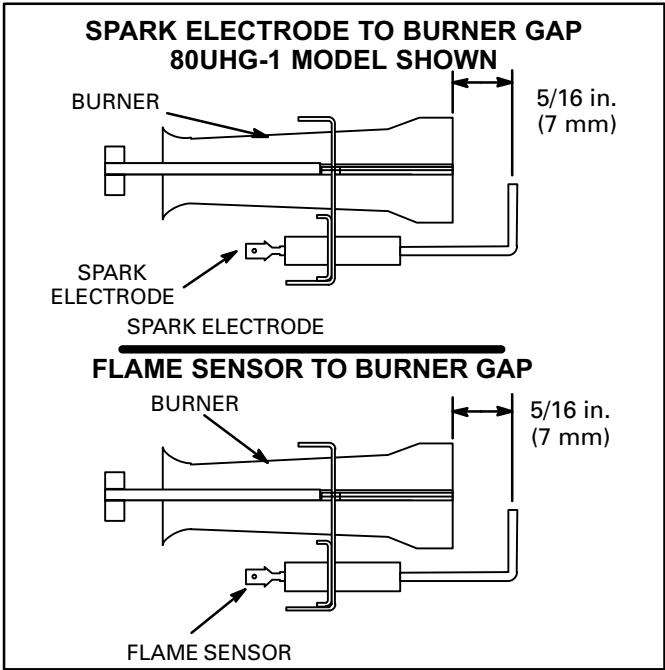

FIGURE 18

13-Combustion Air Blower Prove Switch (S18)

80UHG series units are equipped with a combustion air prove switch located on the vestibule panel. The switch is connected to the combustion air inducer housing by means of a flexible silicone hose. It monitors air pressure in the combustion air blower housing.

The switch is a single-pole single-throw pressure switch electrically connected to the furnace control. The purpose of the switch is to prevent burner operation if the combustion air blower is not operating or if the flue becomes obstructed.

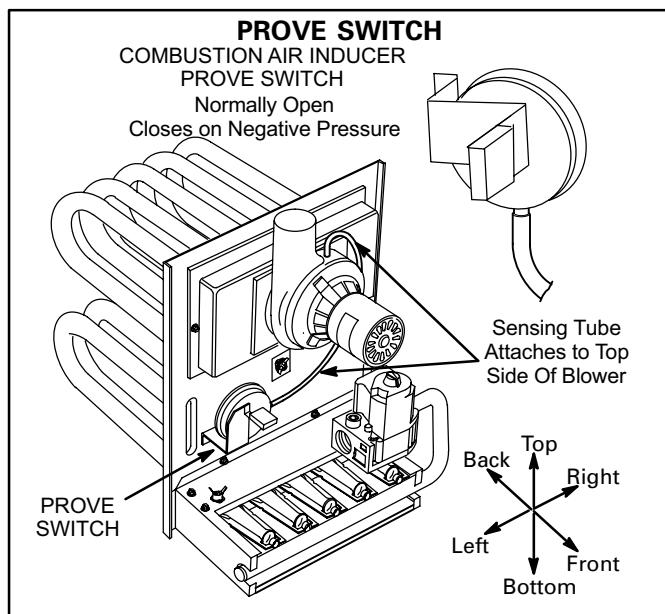

FIGURE 19

On start-up, the switch senses that the combustion air blower is operating. It closes a circuit to the furnace control when pressure inside the combustion air blower decreases to a certain set point. Set points vary depending on unit size. The pressure sensed by the switch is relative to atmospheric pressure. If the flue becomes obstructed during operation, the switch senses a loss of negative pressure (pressure becomes more equal with atmospheric pressure) and opens the circuit to the furnace control and gas valve. A bleed port on the switch allows dry relative air in the vestibule to purge switch tubing, to prevent condensate build up. The switch also has an internal inline orifice, designed to prevent nuisance shut downs due to erratic vent pressure fluctuations.

The switch is factory set and is not field adjustable. It is a safety shut-down control in the furnace and must not be by-passed for any reason. If switch is closed or by-passed, the control will not initiate ignition at start up.

II-PLACEMENT AND INSTALLATION

Make sure unit is installed in accordance with installation instructions and applicable codes.

III-START-UP

A-Preliminary and Seasonal Checks

- 1 - Inspect electrical wiring, both field and factory installed for loose connections. Tighten as required.
- 2 - Check voltage at disconnect switch. Voltage must be within range listed on the nameplate. If not, consult the power company and have voltage condition corrected before starting unit.

B-Heating Start-Up

⚠ WARNING

Shock and burn hazard.

80UHG-1 units are equipped with a direct spark ignition system. Do not attempt to light manually.

- 1 - **STOP!** Read the safety information at the beginning of this section.
- 2 - Set thermostat to lowest setting.
- 3 - Turn off all electrical power to appliance.
- 4 - This appliance is equipped with an ignition device which automatically lights the burners. Do **not** try to light the burners by hand.
- 5 - Remove top access panel.
- 6 - *White Rodgers 36E Gas Valve* -- Switch lever to **OFF**. See figure 15.
Honeywell VR8205 Gas Valve -- Turn knob on gas valve clockwise ➡ to **OFF**. Do not force. See figure 16.
- 7 - Wait five (5) minutes to clear out any gas. If you then smell gas, **STOP!** Close manual main shut-off valve to the furnace. Immediately call your gas supplier from a neighbor's phone. Follow the gas supplier's instructions. If you do not smell gas go to next step.
- 8 - *White Rodgers 36E Gas Valve* -- Switch gas valve lever to **ON**.
Honeywell VR8205 Gas Valve -- Turn knob on gas valve counterclockwise ⬅ to **ON**. Do not force.
- 9 - Replace access panel.
- 10 - Turn on all electrical power to unit.
- 11 - Set thermostat to desired setting.
NOTE--When unit is initially started, steps 1 through 11 may need to be repeated to purge air from pilot line.
- 12 - If the appliance will not operate, follow the instructions "To Turn Off Gas To Unit".

Turning Off Gas To Unit

- 1 - Set thermostat to lowest setting.
- 2 - Turn off all electrical power to unit if service is to be performed.
- 3 - Remove access panel.
- 4 - Switch lever on White Rodgers gas valve to **OFF**; turn knob on Honeywell valve clockwise ➡ to **OFF**. Do not force.
- 5 - Replace access panel.

C-Safety or Emergency Shutdown

Turn off unit power. Close manual and main gas valves.

D-Extended Period Shutdown

Turn off thermostat or set to "UNOCCUPIED" mode. Close all gas valves (both internal and external to unit) to guarantee no gas leak into combustion chamber. Turn off power to unit. All access panels, covers and vent caps must be in place and secured.

IV-HEATING SYSTEM SERVICE CHECKS

A-A.G.A./C.G.A. Certification

All units are A.G.A. and or C.G.A. design certified without modifications. Refer to the 80UHG Operation and Installation Instruction Manual Information.

B-Gas Piping

Gas supply piping should not allow more than 0.5" W.C. drop in pressure between gas meter and unit. Supply gas pipe must not be smaller than unit gas connection.

Compounds used on gas piping threaded joints should be resistant to action of liquefied petroleum gases.

C-Testing Gas Piping

⚠ IMPORTANT

In case emergency shutdown is required, turn off the main shut-off valve and disconnect the main power to unit. These controls should be properly labeled by the installer.

When pressure testing gas lines, the gas valve must be disconnected and isolated. Gas valves can be damaged if subjected to more than 0.5psig (14" W.C.). See figure 20. If the pressure is equal to or less than 0.5psig (14" W.C.), use the manual shut-off valve before pressure testing to isolate furnace from gas supply.

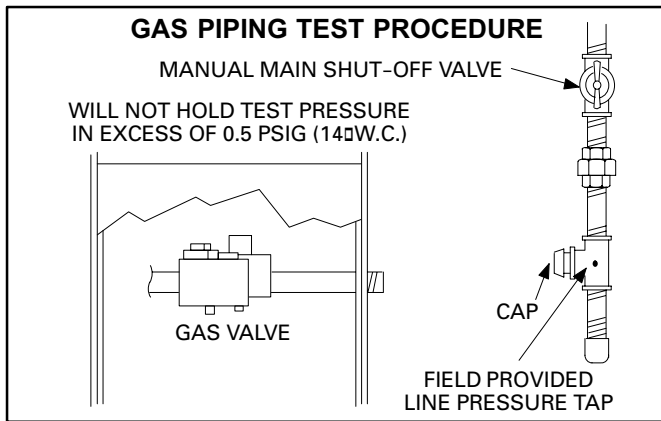

FIGURE 20

When checking piping connections for gas leaks, use preferred means. Kitchen detergents can cause harmful corrosion on various metals used in gas piping. Use of a specialty Gas Leak Detector is strongly recommended. It is available

through Lennox under part number 31B2001. See Corp. 8411-L10, for further details.

Do not use matches, candles, flame or any other source of ignition to check for gas leaks.

D-Testing Gas Supply Pressure

When testing supply gas pressure, connect test gauge to inlet pressure tap (field provided). See figure 20. Check gas line pressure with unit firing at maximum rate. Low pressure may result in erratic operation or underfire. High pressure can result in permanent damage to gas valve or overfire. For 80UHG-45,60 and 75 BTUH natural gas units, operating pressure at the unit must be a minimum 4.5" W.C. For the 80UHG-100 and 120 BTUH units, the operating pressure must be a minimum of 5.0" W.C. For L.P. gas units, operating pressure at unit gas connection must be a minimum of 11.0" W.C.

On multiple unit installations, each unit should be checked separately, with and without other units operating. Supply pressure must fall within range listed in previous paragraph.

E-Check Manifold Pressure

After line pressure has been checked and adjusted, check manifold pressure. Move pressure gauge to outlet pressure tap located on unit gas valve (GV1). Checks of manifold pressure are made as verification of proper regulator adjustment. Manifold pressure for the 80UHG can be measured at any time the gas valve is open and is supplying gas to the unit. Normal manifold pressure for natural gas units is 3.5 in. W.C. For LP/propane gas the correct manifold pressure is 9.5 in. W.C.

⚠ IMPORTANT

For safety, connect a shut-off valve between the manometer and the gas tap to permit shut off of gas pressure to the manometer.

TABLE 9
GAS VALVE REGULATION

Unit (Fuel)	Operating Pressure (outlet) in. W.C.
Natural	3.5 +0 -0.3
L.P.	9.5 ± 0.5

The gas valve is factory set and should not require adjustment. All gas valves are factory regulated. See table 9. See specifications section of this manual for High Altitude manifold pressure settings.

Manifold Adjustment Procedure:

- 1 - Connect a test gauge to outlet pressure tap on gas valve. Start unit and allow 5 minutes for unit to reach steady state.
- 2 - While waiting for the unit to stabilize, notice the flame. Flame should be stable and should not lift from burner. Natural gas should burn blue. L.P. gas should burn mostly blue with some orange streaks.
- 3 - After allowing unit to stabilize for 5 minutes, record manifold pressure and compare to values given in table 9.

NOTE-Shut unit off and remove manometer as soon as an accurate reading has been obtained. Take care to replace pressure tap plug.

F- Proper Gas Flow (Approximate)

Furnace should operate at least 5 minutes before checking gas flow. Determine time in seconds for **two** revolutions of gas through the meter. (Two revolutions assures a more accurate time.) **Divide by two** and compare to time in table 10 below. Adjust manifold pressure on gas valve to match time needed.

NOTE- To obtain accurate reading, shut off all other gas appliances connected to meter.

TABLE 10

GAS METER CLOCKING CHART				
80UHG Unit	Seconds for One Revolution			
	Natural		LP	
	1 cu ft Dial	2 cu ft Dial	1 cu ft Dial	2 cu ft DIAL
-45	80	160	200	400
-60	60	120	150	300
-100	36	72	90	180
-120	30	60	75	150
Natural-1000 btu/cu ft		LP-2500 btu/cu ft		

⚠ IMPORTANT

For safety, shut unit off and remove manometer as soon as an accurate reading has been obtained. Take care to replace pressure tap plug.

G-Flame Signal

A microamp DC meter is needed to check the flame signal on the ignition control.

Flame (microamp) signal is an electrical current which passes from the furnace control through the sensor during unit operation. Current passes from the sensor through the flame to ground to complete a safety circuit.

To Measure Flame Signal - Ignition Control:

A transducer (Part #78H5401 available from Lennox Repair Parts) is required to measure flame signal if meter used will not read a low micro amp signal. See figure 21. The transducer converts microamps to volts on a 1:1 conversion. Flame signal for the EGC control should be 1.0 - 5.0 with a lock-out signal of .45 nominal microamps, therefore a reading of 1.0 - 5.0 nominal volts should be read on the meter. Flame signal for the SureLight control should read 0.7 microamps with a lockout signal of .15 microamps. A digital readout meter must be used. The transducer plugs into most meters. See figure 22 for proper use of transducer.

- 1 - Set the volt meter to the DC voltage scale. Insert transducer into the VDC and common inputs. Observe correct polarities. Failure to do so results in negative (-) values.
- 2 - Turn off supply voltage to control.
- 3 - Disconnect ignition control flame sensor wire from the flame sensor.
- 4 - Connect (-) lead of the transducer to flame sensor.
- 5 - Connect (+) lead of transducer to the ignition control sensor wire.
- 6 - Turn supply voltage on and close thermostat contacts to cycle system.
- 7 - When main burners are in operation for two minutes, take reading. Remember 1 DC volt = 1 DC microamp.

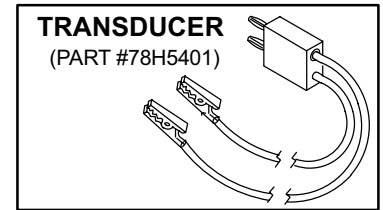

FIGURE 21

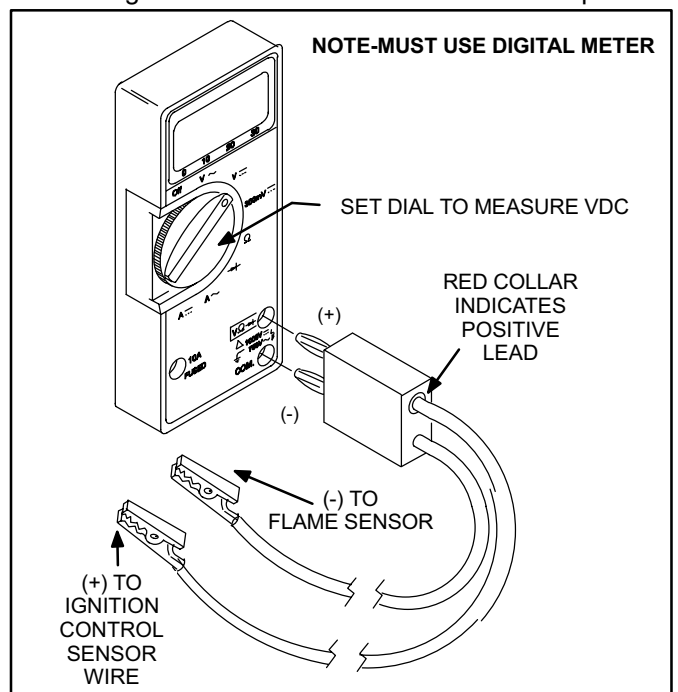

FIGURE 22

⚠ WARNING

Fire and explosion hazard.
These instructions MUST be followed exactly.
Can cause a fire or explosion resulting in property damage, personal injury or loss of life.

V-TYPICAL OPERATING CHARACTERISTICS

A-Blower Operation and Adjustment

NOTE- The following is a generalized procedure and does not apply to all thermostat controls.

- 1 - Blower operation is dependent on thermostat control system.
- 2 - Generally, blower operation is set at thermostat sub-base fan switch. With fan switch in ON position, blower operates continuously on heating speed. With fan switch in AUTO position, blower cycles with demand or runs continuously while heating or cooling circuit cycles.
- 3 - Depending on the type of indoor thermostat, blower and entire unit will be off when the system switch is in OFF position.

B-Temperature Rise

Temperature rise for 80UHG units depends on unit input, blower speed, blower horsepower and static pressure as marked on the unit rating plate. The blower speed must be set for unit operation within the range of "AIR TEMP. RISE °F" listed on the unit rating plate.

To Measure Temperature Rise:

- 1 - Place plenum thermometers in the supply and return air plenums. Locate supply air thermometer in the first horizontal run of the plenum where it will not pick up radiant heat from the heat exchanger.
- 2 - Set thermostat to highest setting.
- 3 - After plenum thermometers have reached their highest and steadiest readings, subtract the two readings. The difference should be in the range listed on the unit rating plate. If the temperature is too low, decrease blower speed. If temperature is too high, first check the firing rate. Provided the firing rate is acceptable, increase blower speed to reduce temperature. To change blower speed taps see the Blower Speed Taps section in this manual.

C-External Static Pressure

- 1 - Tap locations shown in figure 23.

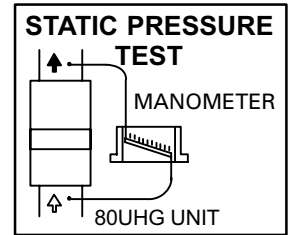

FIGURE 23

- 2 - Punch a 1/4" diameter hole in supply and return air plenums. Insert manometer hose flush with inside edge of hole or insulation. Seal around the hose with permagum. Connect the zero end of the manometer to the discharge (supply) side of the system. On ducted systems, connect the other end of manometer to the return duct as above. For systems with non-ducted returns, leave the other end of the manometer open to the atmosphere.
- 3 - With only the blower motor running and the evaporator coil dry, observe the manometer reading. Adjust blower motor speed to deliver the air desired according to the job requirements.
- 4 - External static pressure drop must not be more than 0.5" W.C.
- 5 - Seal around the hole when the check is complete.

D-Blower Speed Taps Leadless Motors 80UHG-1 Models

Blower speed tap selection is accomplished by changing the taps at the blower motor harness connector. Disconnect harness connector from motor to expose speed selectors. Blower speed selections are listed in table 11.

To Change Blower Speed:

- 1 - Turn off electric power to furnace.
- 2 - Remove blower access door.
Disconnect blower motor harness from motor.
- 3 - Select desired speeds for heating and cooling. (Red = heating, Black = cooling, White = common).
- 4 - Depress harness connector tab to release wire terminal. Select connector location for new speed (refer to unit wiring diagram). Insert wire terminal until it is securely in place. See figure 24.
- 5 - Replace harness connector to motor.

TABLE 11

BLOWER SPEED CHART					
UNIT	FACTORY CONNECTED SPEED TAPS		MOTOR SPEEDS AVAILABLE		
	COOL	HIGH			
Q2-45/60	2	4	4		
Q3-60/75	2	4	4		
Q4-75, 3/4-100	2	4	5		
Q4/5-100/120	2	5	5		
Q2-75	2	3	4		
Q3/4-120	2	3	5		
BLOWER SPEED SELECTION HI ← → LO					
SPEED TAPS	2	3	4	5	4
	2	3	4	5	6

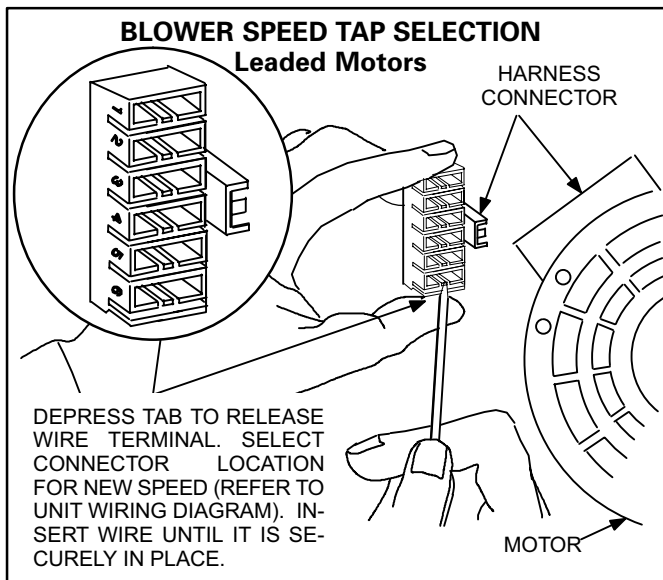

FIGURE 24

E-Blower Speed Taps Leaded Motors 80UHG-2 Models

Blower speed tap changes are made on the SureLight control board. See figure 6. Unused taps must be secured on two dummy terminals labeled "PARK" on the SureLight board. The heating tap is connected to the "HEAT-H" terminal and the cooling tap is connected to the "COOL-H" terminal. The continuous blower tap is the same as the heating tap.

To change existing heat tap, turn off power then switch out speed tap on "HEAT-H" with tap connected to "PARK". See table 12 for blower motor tap colors for each speed.

TABLE 12

BLOWER SPEED CHART (LEADED MOTORS)					
UNIT	FACTORY CONNECTED SPEED TAP			MOTOR SPEEDS AVAILABLE	
	COOL	HEAT			
02-45/60	BLK	YEL		4	
03-60/75	BLK	YEL		4	
04-75, 3/4-100	BLK	BLUE		5	
04/5-100/120	BLK	YEL		5	
02-75	BLK	BN		4	
04/5-150, 3/4-120	BLK	BN		5	
BLOWER SPEED SELECTION HI ← → LO					
SPEED TAP	BLK	BRN	YEL	RED	4
	BLK	BRN	BLUE	YEL	RED

VI-MAINTENANCE

At the beginning of each heating season, the system should be checked as follows:

A-Filters

Return air filter is not supplied with unit. See Optional Accessories section in this manual for filter and rack size. A filter must be used in order to ensure long life and proper operation. The filter is located in the return air duct or return air register. Filters must be cleaned or replaced when dirty to assure proper unit operation.

B- Heat Exchanger and Burners

Due to dimples designed in the heat exchanger, cleaning is not recommended. Removal is for inspection only.

NOTE-Use papers or protective covering in front of furnace while cleaning furnace.

To clean burners:

- 1 - Remove screws holding upper burner mounting rail (figure 17). Remove rail.
- 2 - Slide burners off each orifice pull burners from heat exchanger.
- 3 - Clean holes in burner head (retention ring) with a wire brush. See figure 17.
- 4 - With a shop vacuum or rags, clean out soot and scale deposits from burners.
- 5 - Remove screws securing flue box to vestibule panel. Remove flue box from unit. Leave combustion air blower attached to flue box.
- 6 - With a shop vacuum or rags, clean out soot and scale deposits from heat exchanger tubes and flue box. If turbulators are removed (figure 1) make sure they are re-installed before reassembling units.
- 7 - Inspect heat exchanger for corrosion damage, holes or cracks.
- 8 - Replace burners making sure to fully engage on orifice. Resecure burner mounting rail and flue box. Inspect flue box gasket. Replace gasket if necessary.
- 9 - Slide heat exchanger into cabinet and re-secure heat exchanger screws.
- 10 - Reinstall filler piece making sure that there is a good seal between the cabinet sides, blower and deck and filler piece. Use silicon caulking to fill in any potential gaps.
- 11 - Re-secure flue pipe, gas piping and access panels.
- 12 - Carefully check all piping connections (factory and field) for gas leaks. Use a leak detecting solution or other preferred means.
- 12 - Turn on gas and electrical supply.

HEAT EXCHANGER REMOVAL (unit shown in horizontal position)

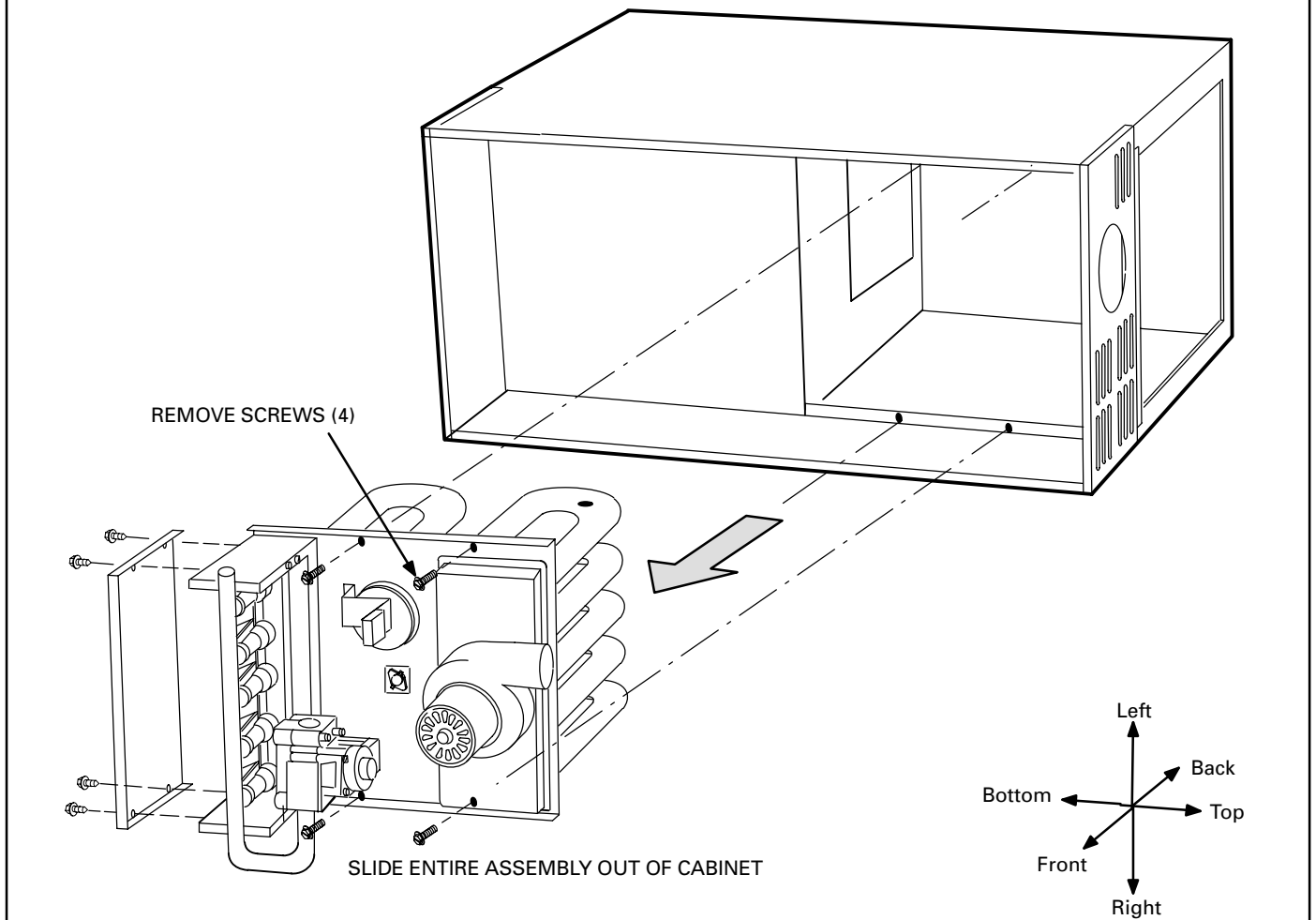

FIGURE 25

⚠ CAUTION

Potential for gas leaks, fire or explosion. Some soaps used for leak detection are corrosive to certain metals. Carefully clean piping thoroughly after leak detection has been completed. Can cause damage to piping resulting in gas leaks, fire or explosion.

C-Supply Air Blower

- 1 - Check and clean blower wheel.
- 2 - Motors used on the Lennox 80UHG series units are permanently lubricated and need no further lubrication.

D-Flue and Chimney

Flue must conform to all AGA/GAMA venting requirements. Flue pipe deteriorates from the inside out and must be disconnected in order to check thoroughly. Check flue pipe, chimney and all connections for tightness and to make sure there is no blockage or leaks.

E-Electrical

- 1 - Check all wiring for loose connections.
- 2 - Check for correct voltage.
- 3 - Check amp-draw on blower motor.

VII- Wiring and Sequence of Operation

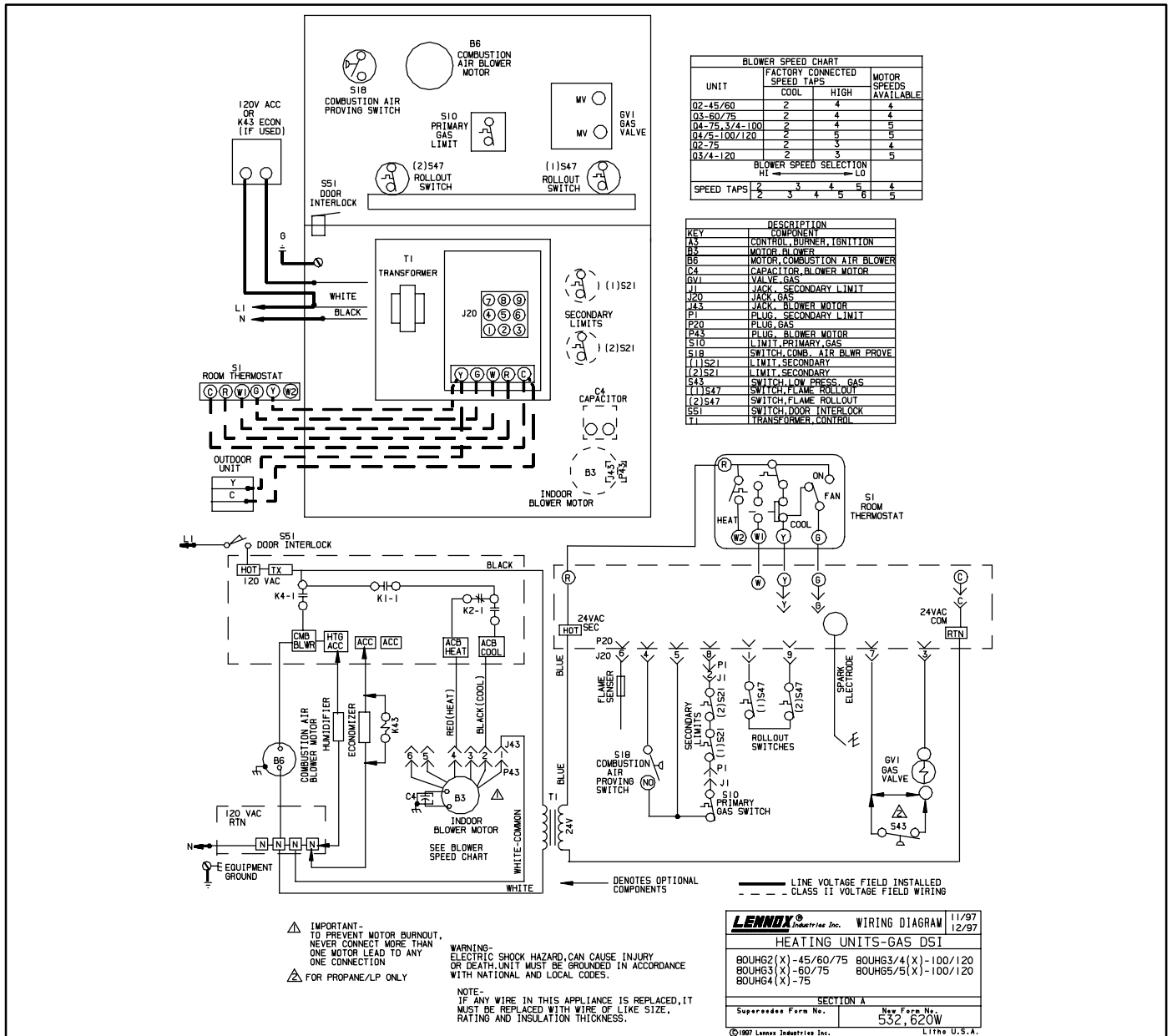

80UHG-1 MODEL WITH EGC CONTROL (SEE FLOW CHARTS ON THE FOLLOWING TWO PAGES):

- 1 - When disconnect is closed, 120V is routed through door interlock switch (S51) to feed the line voltage side of the ignition control (A3) and transformer T1 primary. Door interlock switch must be closed for A3 and T1 to receive voltage.
- 2 - T1 supplies 24VAC to terminal "24VAC" on A3. In turn, terminal "R" of A3 supplies 24VAC to terminal "R" of the indoor thermostat (not shown).
- 3 - When there is a call for heat, W1 of the thermostat energizes W of the ignition control with 24VAC.
- 4 - CAB of the ignition control energizes the combustion air inducer (B6). When the combustion air inducer nears full speed, combustion air prove switch (S18) closes. Switch must close within 2 1/2 minutes or control goes into 5 minute Watchguard Pressure Switch delay.
- 5 - When S18 closes, assuming primary limit (S10) and secondary limit (S21) are closed, a 15 second pre-purge begins. After the pre-purge period the ignition control starts ignition spark and opens main gas valve.
- 6 - After 45 seconds, ignition control (A3) energizes the indoor blower (B3).
- 7 - When heat demand is satisfied, W1 of the thermostat de-energizes W of the ignition control and the gas valve is immediately de-energized. The combustion air inducer immediately stops. The indoor blower runs for a designated fan "off" period (60-240 seconds) as set by jumper on ignition control.

80UHG-1 HEATING SEQUENCE OF OPERATION

NORMAL HEATING MODE

ABNORMAL HEATING MODE

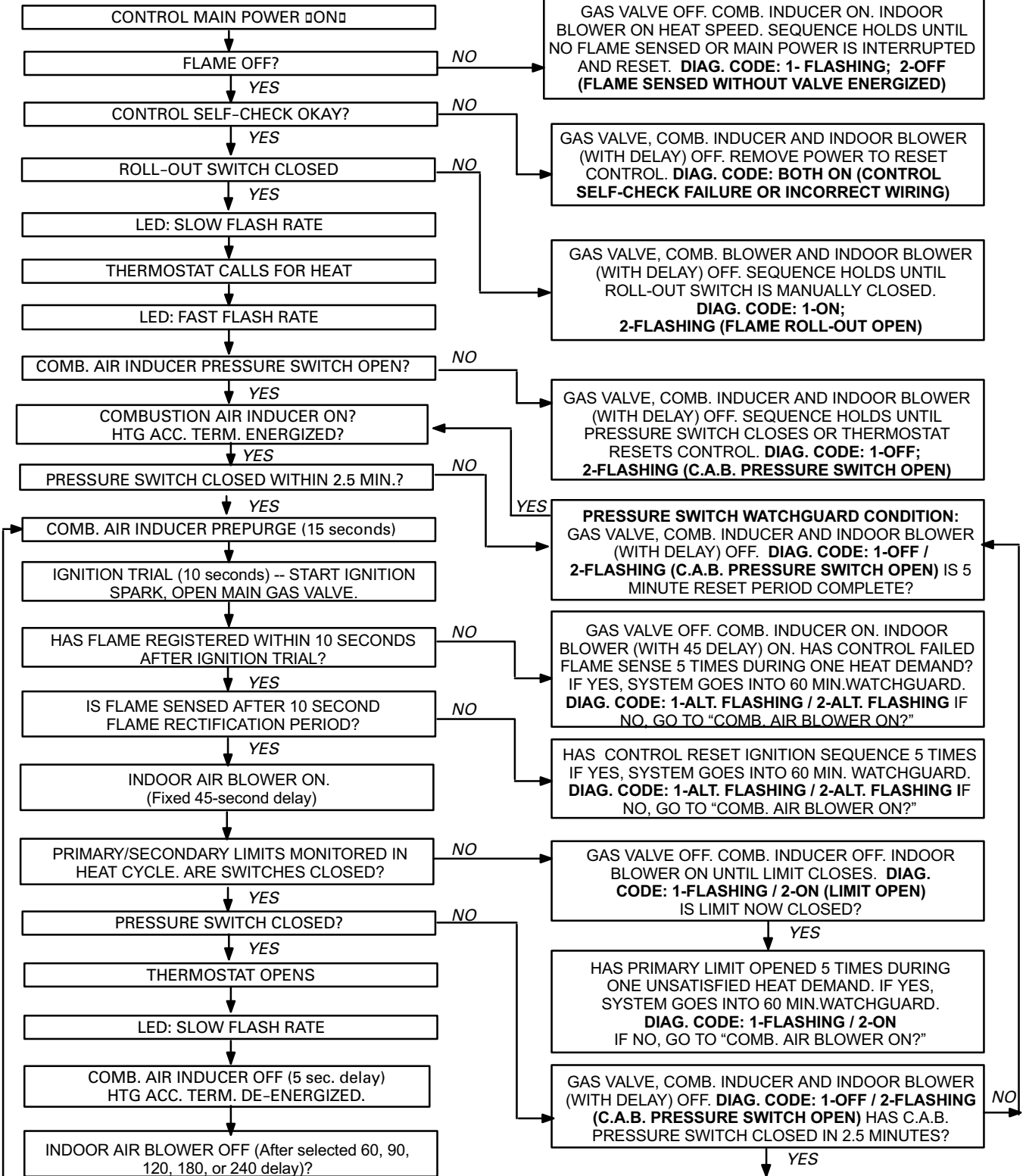

80UHG-1 COOLING SEQUENCE OF OPERATION

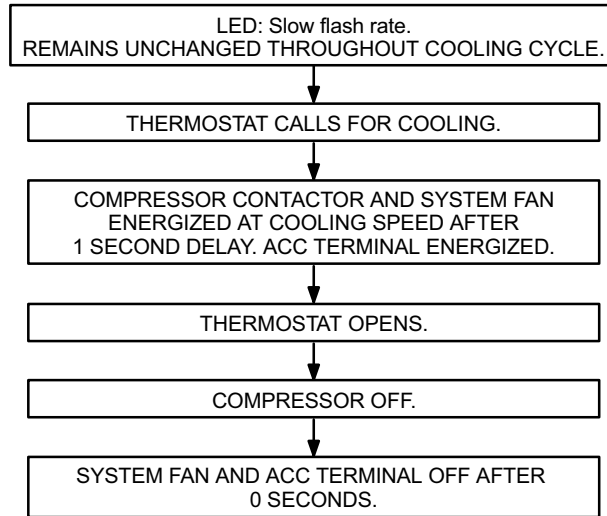

80UHG-1 MANUAL CONTINUOUS FAN SEQUENCE OF OPERATION

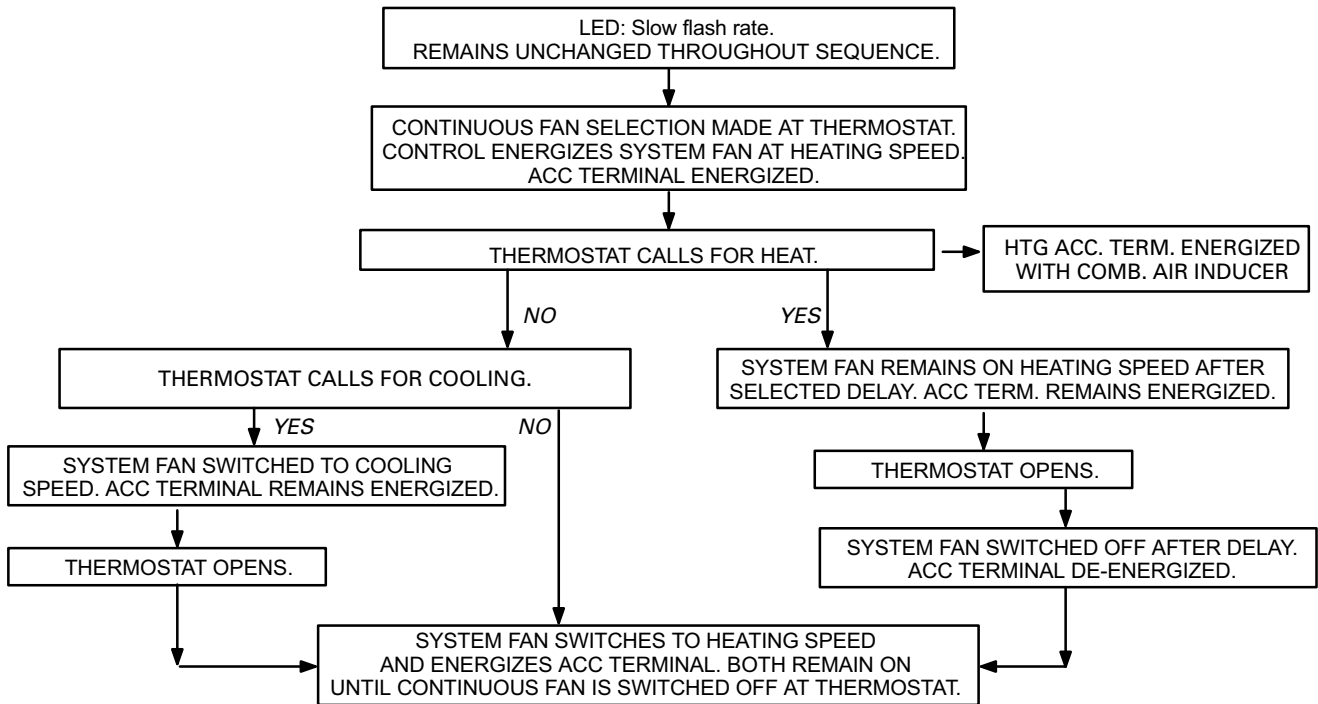

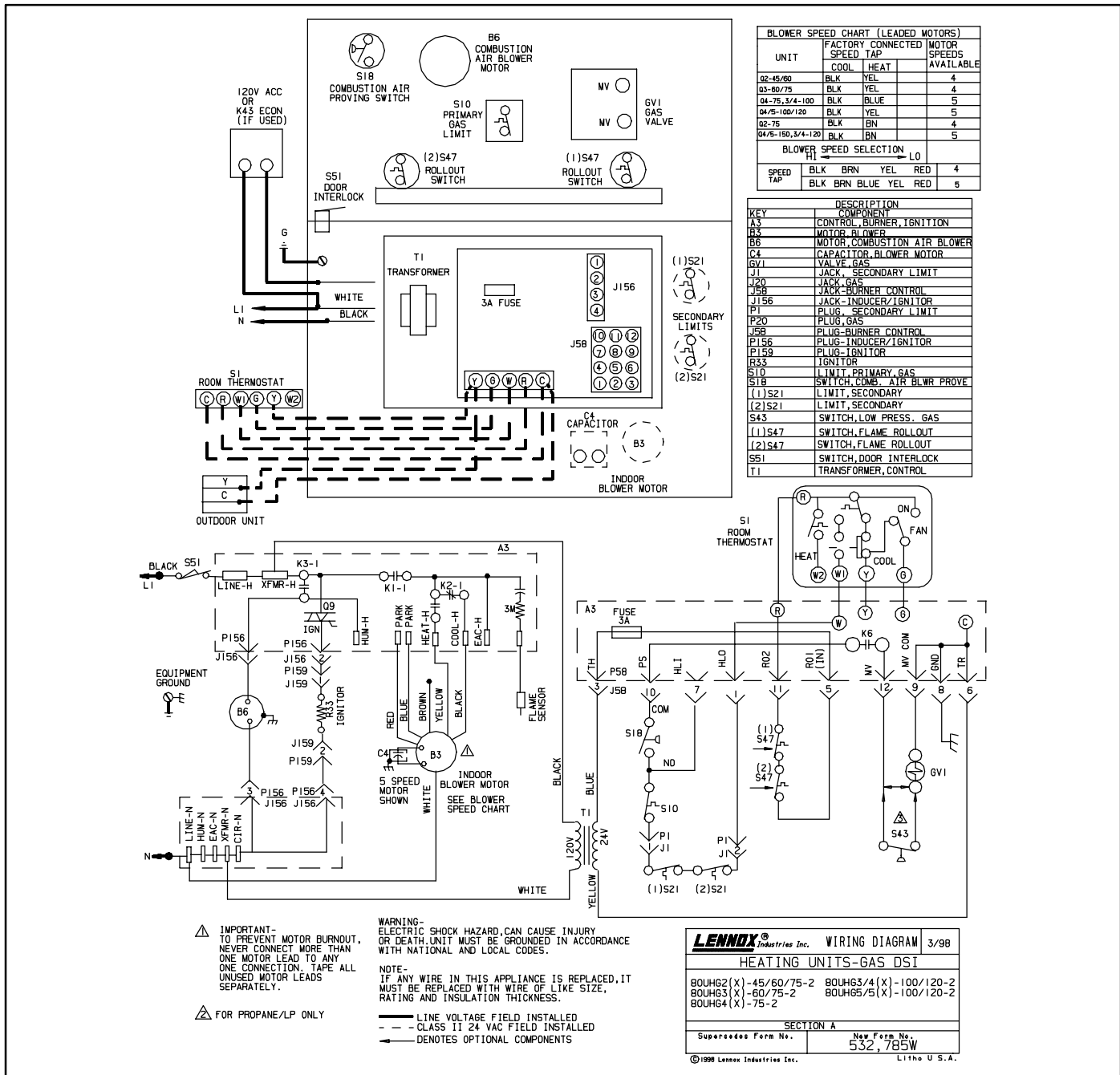

80UHG-2 MODEL WITH SURELIGHT CONTROL

- When there is a call for heat, W1 of the thermostat energizes W of the furnace control with 24VAC.
- S10 primary limit switch and S47 rollout switch are closed. Call for heat can continue.
- SureLight control energizes combustion air blower B6. Combustion air inducer runs until S18 combustion air prove switch closes (switch must close within 2-1/2 minutes or control goes into 5 minute Watchguard Pressure Switch delay). Once S18 closes, a 15-second pre-purge follows.
- SureLight control energizes ignitor. A 20-second warm-up period begins.
- Gas valve opens for a 4-second trial for ignition (ignitor will remain energized for the first second).
- Flame is sensed, gas valve remains open for the heat call.
- After 45-second delay, SureLight control energizes indoor blower B3.
- When heat demand is satisfied, W1 of the indoor thermostat de-energizes W of the SureLight control which de-energizes the gas valve. Combustion air inducer B6 continues a 5-second post-purge period, and indoor blower B3 completes a selected OFF time delay.

HEATING SEQUENCE OF OPERATION

NORMAL HEATING MODE

ABNORMAL HEATING MODE

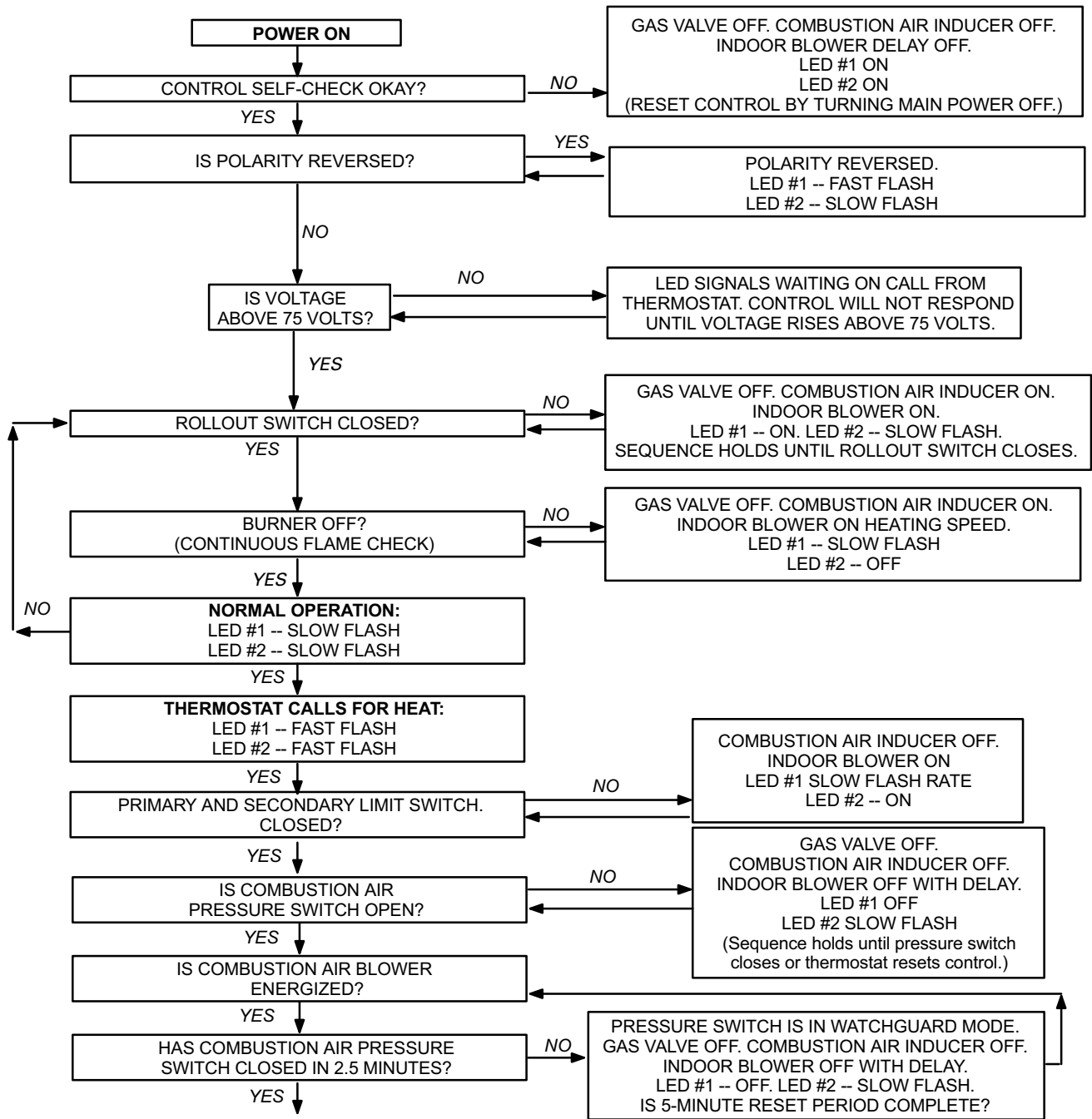

CONTINUED NEXT PAGE

HEATING SEQUENCE CONTINUED

NORMAL HEATING MODE

ABNORMAL HEATING MODE

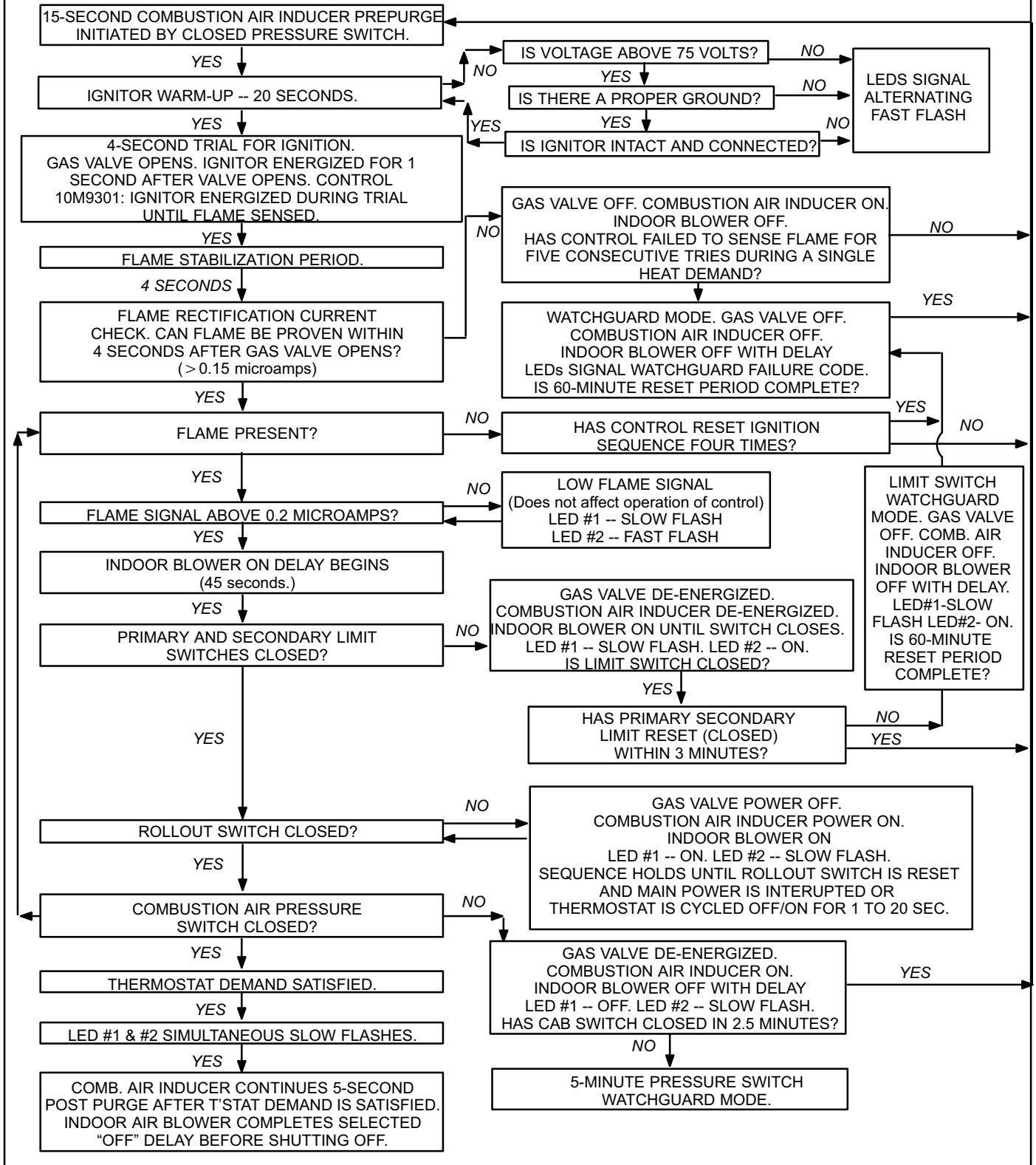

COOLING SEQUENCE OF OPERATION

NORMAL COOLING MODE

ABNORMAL COOLING MODE

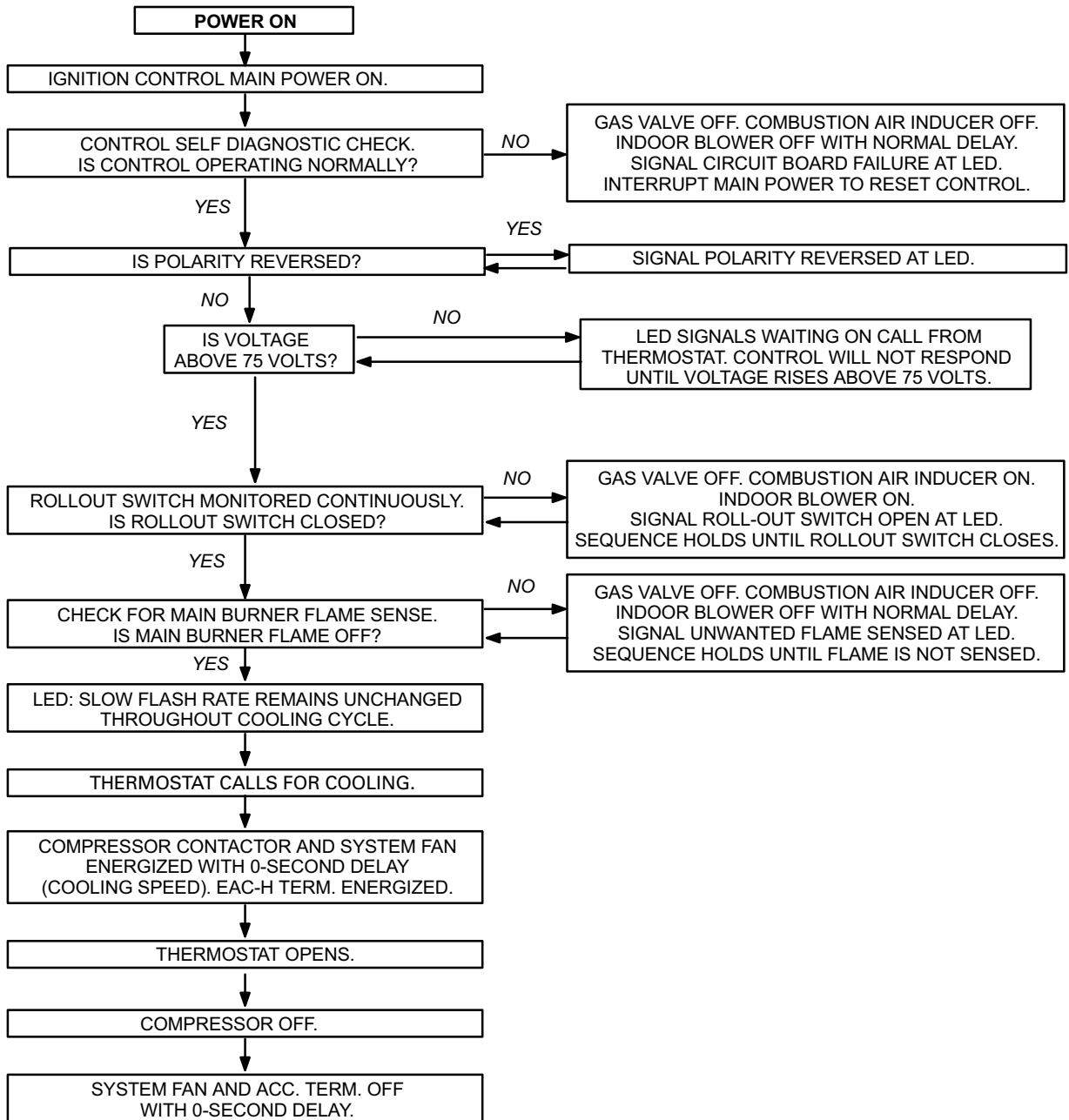

SURELIGHT CONTROL CONTINUOUS HEAT SPEED FAN SEQUENCE OF OPERATION

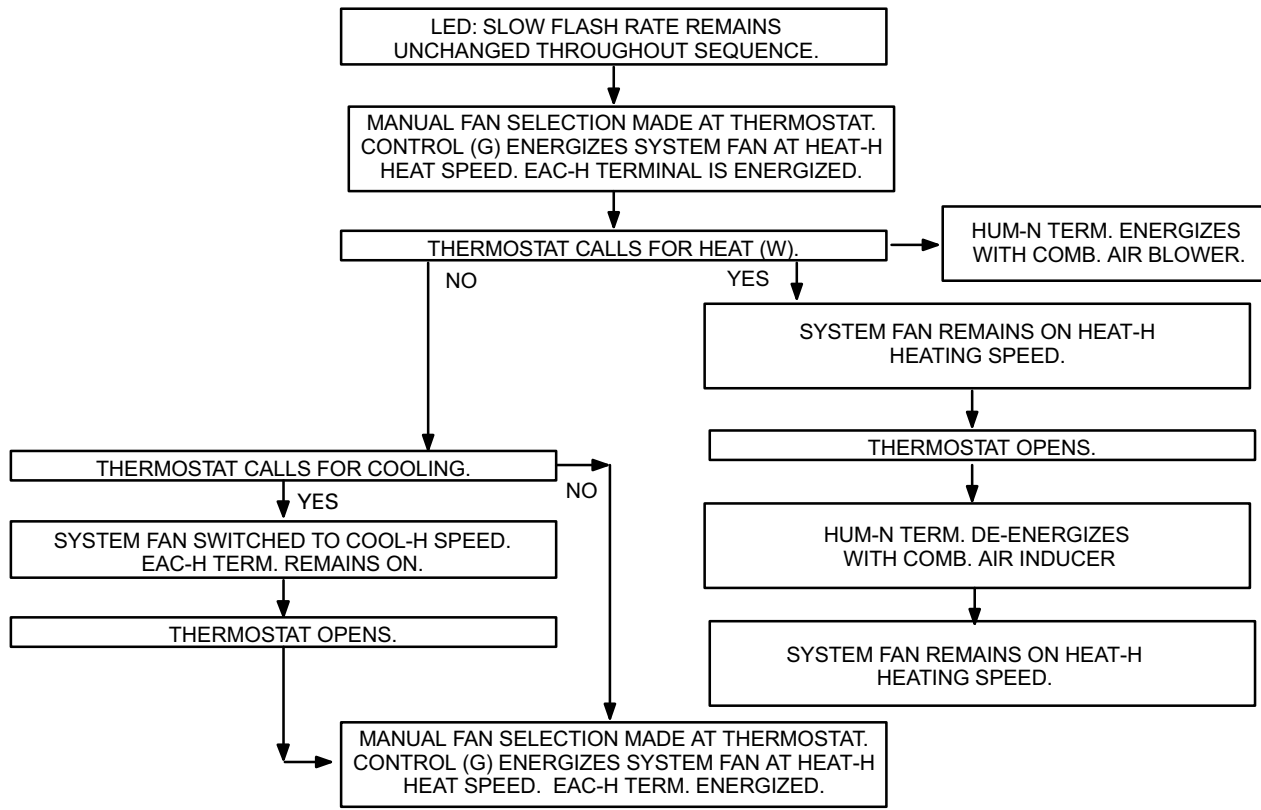

VIII-Troubleshooting-SureLight Control

SURELIGHT - TROUBLE SHOOTING GUIDE

UPON INITIAL POWER UP, REMOVE ALL THERMOSTAT DEMANDS TO THE UNIT

PROBLEM: 1 UNIT FAILS TO OPERATE IN THE COOLING, HEATING, OR CONTINUOUS FAN MODE		
Condition	Possible Cause	Corrective Action / Comments
<p>1.1</p> <p>- Both diagnostic lights fail to light up.</p> <p>LED#1-Off LED#2-Off</p>	<p>1.1.1</p> <p>Main voltage 120V not supplied to unit.</p>	<p>ACTION 1 - Check 120V main voltage. Determine cause of main power failure.</p>
	<p>1.1.2</p> <p>Miswiring of furnace or improper connections.</p>	<p>ACTION 1 - Check for correct wiring of 120V to power make up box and transformer. ACTION 2 - Check 24V wiring to control board.</p>
	<p>1.1.3</p> <p>Blown fuse</p>	<p>ACTION 1 - Replace fuse. ACTION 2 - If fuse still blows, check for short.</p>
	<p>1.1.4</p> <p>Door interlock switch failure.</p>	<p>ACTION 1 - Check that door switch is activated when door is closed. ACTION 2 - Check wire connections to switch, replace loose connectors. ACTION 3 - Check continuity of switch in closed position. Replace if defective.</p>
	<p>1.1.5</p> <p>Transformer Failure.</p>	<p>ACTION 1 - Check that transformer output is 24V. Replace if defective.</p>
	<p>1.1.6</p> <p>Failed control board.</p>	<p>ACTION 1 - If all the above items have been checked, replace board.</p>
<p>1.2</p> <p>- Diagnostic lights flash the roll-out code.</p> <p>LED#1-On, LED#2-Slow Flash</p>	<p>1.2.1</p> <p>Roll-out switch open.</p>	<p>ACTION 1 - Manually reset the roll-out switch by pushing the top button. ACTION 2 - Determine the cause of the roll-out switch activation before leaving furnace.</p>
	<p>1.2.2</p> <p>Roll-out switch failure.</p>	<p>ACTION 1 - Check continuity across roll-out switch. Replace roll-out switch if switch is reset but does not have continuity.</p>
	<p>1.2.3</p> <p>Miswiring or improper connections at roll-out switch.</p>	<p>ACTION 1 - Check wiring connections to switch.</p>
	<p>1.2.4</p> <p>12 pin connector failure</p>	<p>ACTION 1 - Check 12-pin connector for proper connection to control board. ACTION 2 - Check continuity of the multi plug pin.</p>
<p>1.3</p> <p>- On initial power-up the comb. air inducer does not energize. - Diagnostic lights flash the reverse polarity code.</p> <p>LED#1-Fast Flash, LED#2-Slow Flash.</p>	<p>1.3.1</p> <p>120V main power polarity reversed.</p>	<p>ACTION 1 - Check the 120V has line and neutral correctly input into control. ACTION 2 - Reverse the line and neutral at the 120V field connection.</p>
<p>1.4</p> <p>- On initial power up the combustion air inducer does not energize. - Diagnostic lights flash normal power on operation.</p> <p>LED#1-Slow Flash LED#2-Slow Flash</p>	<p>1.4.1</p> <p>Open combustion air inducer motor circuit.</p>	<p>ACTION 1 - Check for 120V to combustion air inducer. If no power, check wire and connections.</p>
	<p>1.4.2</p> <p>Failed combustion air inducer motor.</p>	<p>ACTION 1 - If power is present at blower, replace blower.</p>

PROBLEM 1: UNIT FAILS TO OPERATE IN THE COOLING, HEATING, OR CONTINUOUS FAN MODE

Condition	Possible Cause	Corrective Action / Comments
<p>1.5</p> <p>- Diagnostic lights flash the improper main ground.</p> <p>LED#1-Alternating Fast Flash LED#2-Alternating Fast Flash</p>	<p>1.5.1</p> <p>Improper ground to the unit.</p>	<p>ACTION 1 - Check that the unit is properly ground.</p> <p>ACTION 2 - Install a proper main ground to the unit</p>
	<p>1.5.2</p> <p>4-Pin connector is improperly attached to the circuit board.</p>	<p>ACTION 1 - Check 4-pin connector for proper installation. Correctly insert connector into control.</p>
	<p>1.5.3</p> <p>Line voltage is below 75V.</p>	<p>ACTION 1 - Check that the line voltage is above 75V. Determine cause of voltage drop and supply correct voltage to the control.</p>
	<p>1.5.4</p> <p>Open ignitor circuit.</p>	<p>ACTION 1 - Check for correct wiring and loose connections in the ignitor circuit. Check multi-plug connections for correct installation.</p>
	<p>1.5.5</p> <p>Broken or failed ignitor.</p>	<p>ACTION 1 - Unplug ignitor and read resistance across ignitor. If resistance does not read between 10.9 and 19.7 ohms, replace the ignitor.</p>

PROBLEM 2: UNIT FAILS TO FIRE IN THE HEATING MODE, COMBUSTION AIR BLOWER DOES NOT ENERGIZE

Condition	Possible Cause	Corrective Action / Comments
<p>2.1</p> <p>- Unit operates with a cooling or continuous fan demand.</p> <p>- Combustion air inducer will not start with a Heating demand.</p> <p>- Diagnostic lights flash the limit failure mode.</p> <p>LED#1-Slow Flash, LED#2-On</p>	<p>2.1.1</p> <p>Primary or secondary (if equipped) limit open.</p>	<p>ACTION 1 - Check continuity across switch(es). Switches reset automatically upon cool down.</p> <p>ACTION 2 - Check for restrictions on blower inlet air (including filter) and outlet air. Determine cause for limit activation before placing unit back in operation.</p>
	<p>2.1.2</p> <p>Miswiring of furnace or improper connections at limit switch(es).</p>	<p>ACTION 1 - Check for correct wiring and loose connections. Correct wiring and/or replace any loose connections.</p>
<p>2.2</p> <p>- Unit operates with a cooling and continuous fan demand.</p> <p>- Combustion air inducer will not start with a Heating demand.</p> <p>- Diagnostic lights flash the pressure switch failure code.</p> <p>LED#1-Off, LED#2-Slow Flash</p>	<p>2.2.1</p> <p>Miswiring of furnace or improper connections to combustion air inducer.</p>	<p>ACTION 1 - Check for correct wiring and loose connections. Correct wiring and/or replace any loose connections.</p>
	<p>2.2.2</p> <p>Pressure switch stuck closed.</p>	<p>ACTION 1 - Check that the pressure switch is open without the combustion air inducer operating. Replace if defective.</p>

PROBLEM 2: UNIT FAILS TO FIRE IN THE HEATING MODE, COMBUSTION AIR INDUCER DOES NOT ENERGIZE (CONT.).

Condition	Possible Cause	Corrective Action/Comments
<p align="center">2.3</p> <ul style="list-style-type: none"> - Unit operates with a cooling and continuous fan demand. - Combustion air inducer will not start with a Heating demand. - Diagnostic lights flash the pressure switch failure code 2.5 minutes after heating demand. <p>LED#1-Off, LED#2-Slow Flash</p>	<p>2.3.1</p> <p>Miswiring of furnace or improper connections to combustion air inducer.</p>	<p>ACTION 1 - Check for correct wiring and loose connections. Correct wiring and/or replace any loose connections.</p>
	<p>2.3.2</p> <p>Combustion air inducer failure.</p>	<p>ACTION 1 - If there is 120V to combustion air inducer and it does not operate, replace combustion air inducer.</p>

PROBLEM 3: UNIT FAILS TO FIRE IN THE HEATING MODE, COMBUSTION AIR BLOWER ENERGIZES, IGNITOR IS NOT ENERGIZED.

Condition	Possible Cause	Corrective Action/Comments
<p align="center">3.1</p> <ul style="list-style-type: none"> - Unit operates with a cooling and continuous fan demand. - Combustion air inducer energizes with a heating demand. - Diagnostic lights flash the pressure switch failure code 2.5 minutes after heating demand. <p>LED#1-Off LED#2-Slow Flash</p>	<p>3.1.1</p> <p>Pressure switch does not close due to incorrect routing of the pressure switch lines.</p>	<p>ACTION 1 - Check that the pressure switch lines are correctly routed. Correctly route pressure switch lines.</p>
	<p>3.1.2</p> <p>Pressure switch does not close due to obstructions in the pressure lines.</p>	<p>ACTION 1 - Remove any obstructions from the the pressure lines and/or taps.</p>
	<p>3.1.3</p> <p>Pressure switch lines damaged</p>	<p>ACTION 1 - Check pressure switch lines for leaks. Replace any broken lines.</p>
	<p>3.1.4</p> <p>Condensate in pressure switch line.</p>	<p>ACTION 1 - Check pressure switch lines for condensate. Remove condensate from lines. Check that the condensate lines are located correctly.</p>
	<p>3.1.5</p> <p>Pressure switch does not close due to a low differential pressure across the pressure switch.</p>	<p>ACTION 1 - Check the differential pressure across the pressure switch. This pressure should exceed the set point listed on the switch.</p> <p>ACTION 2 - Check for restricted inlet vent. Remove all blockage.</p> <p>ACTION 3 - Check for proper vent sizing and run length. See installation instructions.</p>
	<p>3.1.6</p> <p>Wrong pressure switch installed in the unit, or pressure switch is out of calibration.</p>	<p>ACTION 1 - Check that the proper pressure switch is installed in the unit. Replace pressure switch if necessary.</p>
	<p>3.1.7</p> <p>Miswiring of furnace or improper connections at pressure switch.</p>	<p>ACTION 1 - Check for correct wiring and loose connections. Correct wiring and/or replace any loose connections.</p>
	<p>3.1.8</p> <p>Pressure switch failure.</p>	<p>ACTION 1 - If all the above modes of failure have been checked, the pressure switch may have failed. Replace pressure switch and determine if unit will operate.</p>

PROBLEM 4: UNIT FAILS TO FIRE IN THE HEATING MODE, COMBUSTION AIR BLOWER ENERGIZES, IGNITOR IS ENERGIZED.

Condition	Possible Cause	Corrective Action/Comments
<p align="center">4.1</p> <ul style="list-style-type: none"> - Unit operates with a cooling and continuous fan demand. - Combustion air inducer energizes with Heating demand. - Ignitor is energized but unit fails to light. <p>LED#1-Alternating Slow Flash LED#2-Alternating Slow Flash</p>	<p align="center">4.1.1</p> <p>Check that gas is being supplied to the unit.</p>	<p>ACTION 1 - Check line pressure at the gas valve. Pressure should not exceed 13" WC for both natural and propane. Line pressure should read a minimum 4.5" WC for natural and 8.0"WC for propane.</p>
	<p align="center">4.1.2</p> <p>Miswiring of gas valve or loose connections at multi-pin control amp plugs or valve.</p>	<p>ACTION 1 - Check for correct wiring and loose connections. Correct wiring and/or replace any loose connections.</p>
	<p align="center">4.1.3</p> <p>Defective gas valve or ignition control.</p>	<p>ACTION 1 - Check that 24V is supplied to the gas valve approximately 35 seconds after heat demand is initiated. ACTION 2 - Replace the valve if 24V is supplied but valve does not open. ACTION 3 - Replace the control board if 24V is not supplied to valve.</p>

PROBLEM 5: BURNERS LIGHT WITH A HEATING DEMAND BUT UNIT SHUTS DOWN PREMATURELY

Condition	Possible Cause	Corrective Action/Comments
<p align="center">5.1</p> <ul style="list-style-type: none"> - Burners fire with a heating demand. - Burners light but unit shuts off prior to satisfying T-stat demand. - Diagnostic lights flash the pressure switch code. <p>LED#1-Off LED#2-Slow Flash</p>	<p align="center">5.1.1</p> <p>Low pressure differential at the pressure switch.</p>	<p>ACTION 1 - Check for restricted exhaust vent. Remove all blockage. ACTION 2: Check for proper vent sizing. See installation instructions.</p>
	<p align="center">5.2</p> <ul style="list-style-type: none"> - Combustion air inducer energizes with a heating demand. - Burners light but fail to stay lit. - After 5 tries the control diagnostics flash the watchguard burners failed to ignite code. <p>LED#1-Alternating Slow Flash LED#2-Alternating Slow Flash</p>	<p align="center">5.2.1</p> <p>Sensor or sensor wire is improperly installed.</p>
	<p align="center">5.2.2</p> <p>Sensor or sensor wire is broken.</p>	<p>ACTION 1 - Check for a broken sensor. ACTION 2 - Test continuity across the sense wire. If wire or sensor are damaged replace the component.</p>
	<p align="center">5.2.3</p> <p>Sensor or sensor wire is grounded to the unit.</p>	<p>ACTION 1 - Check for resistance between the sensor rod and the unit ground. ACTION 2 - Check for resistance between the sensor wire and the unit ground. ACTION 3 - Correct any shorts found in circuit.</p>
	<p align="center">5.2.4</p> <p>Control does not sense flame.</p>	<p>ACTION 1 - Check the microamp signal from the burner flame. If the microamp signal is below 0.20 microamps, check the sensor rod for proper location or contamination. ACTION 2 - Replace, clean, or relocate flame sensor rod. If rod is to be cleaned, use steel wool or replace sensor. DO NOT CLEAN ROD WITH SAND PAPER. SAND PAPER WILL CONTRIBUTE TO THE CONTAMINATION PROBLEM. NOTE: Do not attempt to bend sensor rod. ACTION 3 - Check that there is proper ground to burner box. Repair as necessary.</p>

**PROBLEM 5: BURNERS LIGHT WITH HEATING DEMAND BUT UNIT SHUTS DOWN
PREMATURELY (CONT.)**

Condition	Possible Cause	Corrective Action/Comments
<p align="center">5.3</p> <ul style="list-style-type: none"> - Combustion air inducer energizes with a heating demand. - Burners light. - Roll-out switch trips during the heating demand. - Diagnostic lights flash roll-out failure. <p>LED#1-On LED#2-Slow Flash</p>	<p align="center">5.3.1</p> <p align="center">Unit is firing above 100% of the nameplate input.</p>	<p>ACTION 1 - Check that the manifold pressure matches value listed on nameplate. See installation instructions for proper procedure. ACTION 2 - Verify that the installed orifice size match the size listed on the nameplate or installation instructions. ACTION 3 - Check the input rate to verify rate matches value listed on nameplate.</p>
	<p align="center">5.3.2</p> <p align="center">Gas orifices leak at the manifold connection.</p>	<p>ACTION 1 - Tighten orifice until leak is sealed. NOTE: Be careful not to strip orifice threads. ACTION 2 - Check for gas leakage at the threaded orifice connection. Use approved method for leak detection (see unit instructions).</p>
	<p align="center">5.3.3</p> <p align="center">Insufficient flow through the heat exchanger caused by a sooted or restricted heat exchanger.</p>	<p>ACTION 1 - Check for sooting deposits or other restrictions in the heat exchanger assembly. Clean assembly as outlined in instruction manual. ACTION 2 - Check for proper combustion. See NO TAG Heating System Service Checks section NO TAG.</p>
	<p align="center">5.3.4</p> <p align="center">Burners are not properly located in the burner box.</p>	<p>ACTION 1 - Check that the burners are firing into the center of the heat exchanger openings. Correct the location of the burners if necessary.</p>
<p align="center">5.4</p> <ul style="list-style-type: none"> - Combustion air inducer energizes with a heating demand. - Burners light roughly and the unit fails to stay lit. - Diagnostic lights flash watchguard flame failure. <p>LED#1-Alternating Slow Flash LED#2-Alternating Slow Flash</p>	<p align="center">5.4.1</p> <p align="center">Poor Venting</p>	<p>ACTION 1 - Check vent pipe and remove any obstructions ACTION 2 - Check for correct exhaust vent installation. See instructions</p>
	<p align="center">5.4.2</p> <p align="center">Improper burner cross-overs</p>	<p>ACTION 1 - Remove burner and inspect the cross-overs for burrs, or any restriction or if crossover is warped. Remove restriction or replace burners.</p>
	<p align="center">5.4.3</p> <p align="center">Burrs in gas orifices</p>	<p>ACTION 1 - Remove gas orifices and inspect. Remove any burrs that are present or replace orifice.</p>
<p align="center">5.5</p> <ul style="list-style-type: none"> - Combustion air inducer energizes with a heating demand. - Burners light. - Diagnostic lights flash watch guard flame failure. - NOTE" Unit might go into 60 minute Watchguard mode depending on intermittent nature of sensor signal. <p>LED#1-Alternating Slow Flash LED#2-Alternating Slow Flash</p>	<p align="center">5.5.1</p> <p align="center">Loose sensor wire connection causes intermittent loss of flame signal.</p>	<p>ACTION 1 - Check that the sensor is properly located. ACTION 2 - Check that the sense wire is properly attached to both the sensor and the control. Pay extra attention to the pin connectors.</p>
	<p align="center">5.5.2</p> <p align="center">Poor ground to burner box</p>	<p>ACTION 1 - Check for proper ground and repair as necessary.</p>

PROBLEM 6: CONTROL SIGNALS LOW FLAME SENSE DURING HEATING MODE

Condition	Possible Cause	Corrective Action/Comments
6.0 - Unit operates correctly but the diagnostic lights flash low flame sense code. LED#1-Slow Flash LED#2-Fast Flash	6.1.1 Sensor rod is improperly located on the burner.	ACTION 1 - Check the sensor rod for proper location on the burner. Properly locate the sensor rod or replace if rod cannot be located correctly.
	6.1.2 Sensor rod is contaminated.	ACTION 1 - Check sensor rod for contamination or coated surface. Clean the sensor rod with steel wool or replace sensor. DO NOT USE SAND PAPER TO CLEAN ROD. SAND PAPER WILL CONTRIBUTE TO THE CONTAMINATION PROBLEM.

PROBLEM 7: INDOOR BLOWER FAILS TO OPERATE IN COOLING, HEATING, OR CONTINUOUS FAN MODE

Condition	Possible Cause	Corrective Action/Comments
7.0 - Indoor blower fails to operate in continuous fan, cooling, or heating mode.	7.1.1 Miswiring of furnace or improper connections at control or indoor blower motor.	ACTION 1 - Correct wiring and/or replace any loose connections. Check for correct wiring and loose connections.
	7.1.2 120V is not being supplied to the indoor air blower or blower motor failure.	ACTION 1 - Check for 120V at the various calls for indoor blower by energizing "Y", "G", and "W" individually on the low voltage terminal strip. Note that when "W" is energized, the blower is delayed 45 seconds. If there is 120V to each motor tap but the blower does not operate, replace the motor.
	7.1.3 Defective control board	ACTION 1 - If there is not 120V when "Y", "G", or "W" is energized, replace the control.
	7.1.4 Defective run capacitor	ACTION 1 - Replace capacitor

PROBLEM 8: RF STATIC DURING TIME FOR IGNITION

Condition	Possible Cause	Corrective Action/Comments
8.0 - AM radio interference.	8.1.2 Ignitor operation	ACTION 1 - Call Technical Support, Dallas.