



Installation, Start-Up and Service Instructions

CONTENTS

	Page
SAFETY CONSIDERATIONS	1
GENERAL	1,2
INSTALLATION	2-14
Step 1 – Complete Pre-Installation Checks	2
• UNPACK UNIT	
• INSPECT SHIPMENT	
Step 2 – Select Location	2
Step 3 – Mount Mounting Bracket on Wall	5
Step 4 – Connect Refrigerant Piping	5
Step 5 – Connect Condensate Drain Line	11
Step 6 – Make Electrical Connections	12
Step 7 – Make Connections to Outdoor Unit	13
• COOLING-ONLY SYSTEMS	
• HEAT PUMP SYSTEMS	
Step 8 – Install Fan Coil Unit Onto Mounting Bracket	13
START-UP	14-17
40QN Control System	14
After Extended Shutdowns	15
Seasonal Changeovers	15
To Turn The Unit On and Off	15
Adjusting Airflow	15
Operating Mode Memory	15
Automatic Operation (Auto) Mode	15
Operating Fault Diagnosis	15
Microprocessor Control Operation	15
CLEANING AND MAINTENANCE	18,19
Lubrication	18
To Install or Replace Remote Controller Batteries	18
To Set the Current Time	19
To Remove and Clean or Replace Air Filters	19
• TO REMOVE AIR FILTERS	
• TO CLEAN OR REPLACE FILTERS	
To Clean Indoor Unit Front Panel	19
To Clean Indoor Coil	19
To Clean Outdoor Coil (Outdoor Unit)	19
Cleaning Condensate Drains	19
SERVICE	20
Diagnostic Codes	20
System Tests	20
• THERMISTOR TESTS	
• THERMISTORS	
• COMPRESSOR FAILURE	
• REVERSING VALVE FAILURE (38BK Only)	
System Safeties and Interlocks	20
• INDOOR FAN FAILURE	
• COMPRESSOR SHORT-CYCLING PROTECTION	
• INDOOR COIL FREEZE PROTECTION (Cooling or Dehumidification Mode Only)	
• INDOOR COIL HIGH-TEMPERATURE PROTECTION (Heat Pump Systems Only)	
TROUBLESHOOTING	20-26
START-UP CHECKLIST	CL-1,CL-2

SAFETY CONSIDERATIONS

Installing and servicing air-conditioning equipment can be hazardous due to system pressure and electrical components. Only trained and qualified service personnel should install or service air-conditioning equipment.

Untrained personnel can perform basic maintenance, such as cleaning and replacing filters. All other operations should be performed by trained service personnel. When working on air conditioning equipment, observe precautions in literature and on tags and labels attached to unit.

Follow all safety codes. Wear safety glasses and work gloves. Use quenching cloth for brazing operations. Have fire extinguisher available. Read these instructions *thoroughly*. Consult local building codes and National Electrical Code (NEC) for special installation requirements.

⚠ WARNING

Before installing or servicing system, always turn off main power to system. There may be more than one disconnect switch. Turn off indoor fan coil power if applicable. Electrical shock can cause personal injury.

GENERAL

The Carrier 40QNH heat pump high wall fan coil units (Fig. 1) come with supplemental electric heat. If your application requires heating, heat pump units must be used, both outdoors and indoors. See Table 1 for recommended system combinations.

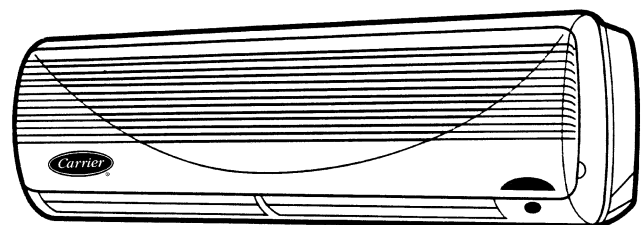

Fig. 1 — Typical 40QNH High Wall Fan Coil Unit

Table 1 — System Combinations for Indoor and Outdoor Units

SYSTEM	INDOOR UNIT	OUTDOOR UNIT
High Wall Cooling Only	40QNB018 40QNB024	38HDC,L018 38HDC,L024
	(2) 40QNB018 (4) 40QNB018 40QNB024, (2) 40QNB018 (2) 40QNB024	38HDS024* 38HDS048* 38HDS048* 38HDS048*
High Wall Heat Pump	40QNH018 40QNH024	38BK018 38BK024

*Multi-split systems can accommodate up to 4 fan coil units of various types with one condensing unit. The combinations listed in this table are those which use only high-wall units (not in combination with any other type of fan coil unit). Refer to system presale literature or Price Pages for more details.

NOTE: Numbers in () indicate quantities of more than 1. See Fig. 1 for 40QN high wall fan coil unit.

INSTALLATION

The 40QNB high wall fan coil unit is installed with either the 38HDC,HDL condensing or 38HDS multi-split condensing outdoor unit, and the 40QNH unit is installed with the 38BK heat pump outdoor unit. Refer to Table 1 to make sure the correct indoor unit(s) is installed with the correct outdoor unit.

Installation instructions for the 40QN fan coil units are contained in this manual. Refer to this manual for proper installation of the complete system. Note that the 38HDC, HDL, and BK outdoor units are shipped with installation and service instructions for basic installation of the outdoor section. Be sure to make the modifications in Make Connections to Outdoor Unit section on page 13 of this literature, so that the outdoor unit will operate properly with the 40QN control system. Be sure the unit will be operated within the application guidelines shown in Table 2. When installing the 38HDC, HDL, HDS, or BK unit, note that for cooling operation below 55 F (38HDC, HDL, BK), it is necessary to equip the outdoor unit with the low ambient control accessory. The low ambient control is standard on 38HDS units.

To install this system, you will need:

- 40QNB or QNH fan coil unit(s)* with standard wireless remote controller
- 38HDC, HDL, HDS, or BK outdoor unit
- low-ambient (38HDC, HDL, BK) or winter start (38HDS) kit (if required for your application)

* More than one fan coil unit may be used with the 38HDS multi-split units. Refer to 38HDS system Price Pages for full details.

NOTE: Refrigerant pipe, drain pipe, wire, etc., are also required to install unit and are field supplied.

Be sure you have the required parts before beginning installation. The 40QN unit utilizes a microprocessor control system to deliver optimum levels of comfort and efficiency. Be sure to follow these instructions carefully to obtain proper functioning of the unit.

Step 1 — Complete Pre-Installation Checks

UNPACK UNIT — Store unit in the original packaging until it is moved to the final site for installation. When removing unit from carton, lift by its 4 corners. Also, note that there is a plastic bag containing mounting screws taped to the mounting bracket.

INSPECT SHIPMENT — Upon receipt of shipment check unit (Fig. 1) for damage. Forward claim papers directly to the transportation company. Manufacturer is not responsible for damage incurred in transit.

Table 2 — Application Ranges

COOLING MODE			
Maximum		Minimum	
Indoor Unit	Outdoor Unit	Indoor Unit	Outdoor Unit
95 F DB 71 F WB	115 F DB	67 F DB 57 F WB	55 F DB* 0° F DB†
HEATING MODE (38BK Systems Only)			
Maximum		Minimum	
Indoor Unit	Outdoor Unit	Indoor Unit	Outdoor Unit
80 F DB 71 F WB	75 F DB 65 F WB	55 F DB	0° F DB

LEGEND

DB — Dry Bulb
WB — Wet Bulb

*38HDC, HDL and BK systems only.
†38HDS systems only.

NOTE: Unit may be equipped with a low-ambient control (HDC, HDL, BK) or winter start kit (HDS) that will allow operation down to -20 F.

Check all items. See Table 3. If any item is missing notify your Carrier distributor. To prevent loss or damage, leave all parts in original packages until installation.

Step 2 — Select Location — Consult local building codes and NEC for special installation requirements.

There are several ways the unit may be installed to different types of wall construction. These instructions do not cover all installation methods. As a typical installation, these instructions focus primarily on mounting the unit to wall studs in new construction. See Fig. 2 for unit dimensions and Fig. 3 for required clearances. Plan your installation carefully before you begin. Listed below are some guidelines that should be followed when determining location for the unit.

1. Center unit (horizontally) on the wall selected.
2. Place the unit so it faces normal location of room occupants.
3. Allow sufficient space for airflow clearance, wiring, refrigerant piping, and servicing unit. See Fig. 2 and 3.
4. Select walls that are:
 - a. Strong enough to support weight of the unit.
 - b. Accessible to convenient condensate drainage.
 - c. Free of obstacles that may block air circulation to the fan coils.
 - d. Outside walls (if possible) to make piping easier.
5. Place top of fan coil unit as high on the wall as possible making sure the unit is at least 10 in. down from ceiling to permit proper air intake. Also, make sure that the unit is not placed directly over anything to prevent filter removal or block airflow.
6. Make sure units are easily accessible to electrical power.
7. Refrigerant piping can enter the unit through the prepunched holes. Refrigerant piping can run up or down along the wall, to the right or left along the wall, straight through the wall, or into the wall (Fig. 4). Once the piping is through the wall, it can run inside walls, in ceilings, between floors, or straight to the outside. See Fig. 5 for maximum line lengths.

NOTE: Run refrigerant piping as directly as possible, and avoid any unnecessary turns or bends.

8. Condensate piping can be directed through the inside wall to an approved drain, or directed straight outside.

NOTE: The piping hole for condensate line must be made at a downward slope to ensure proper drainage. See Mount Mounting Bracket on Wall Section on page 5 for details.

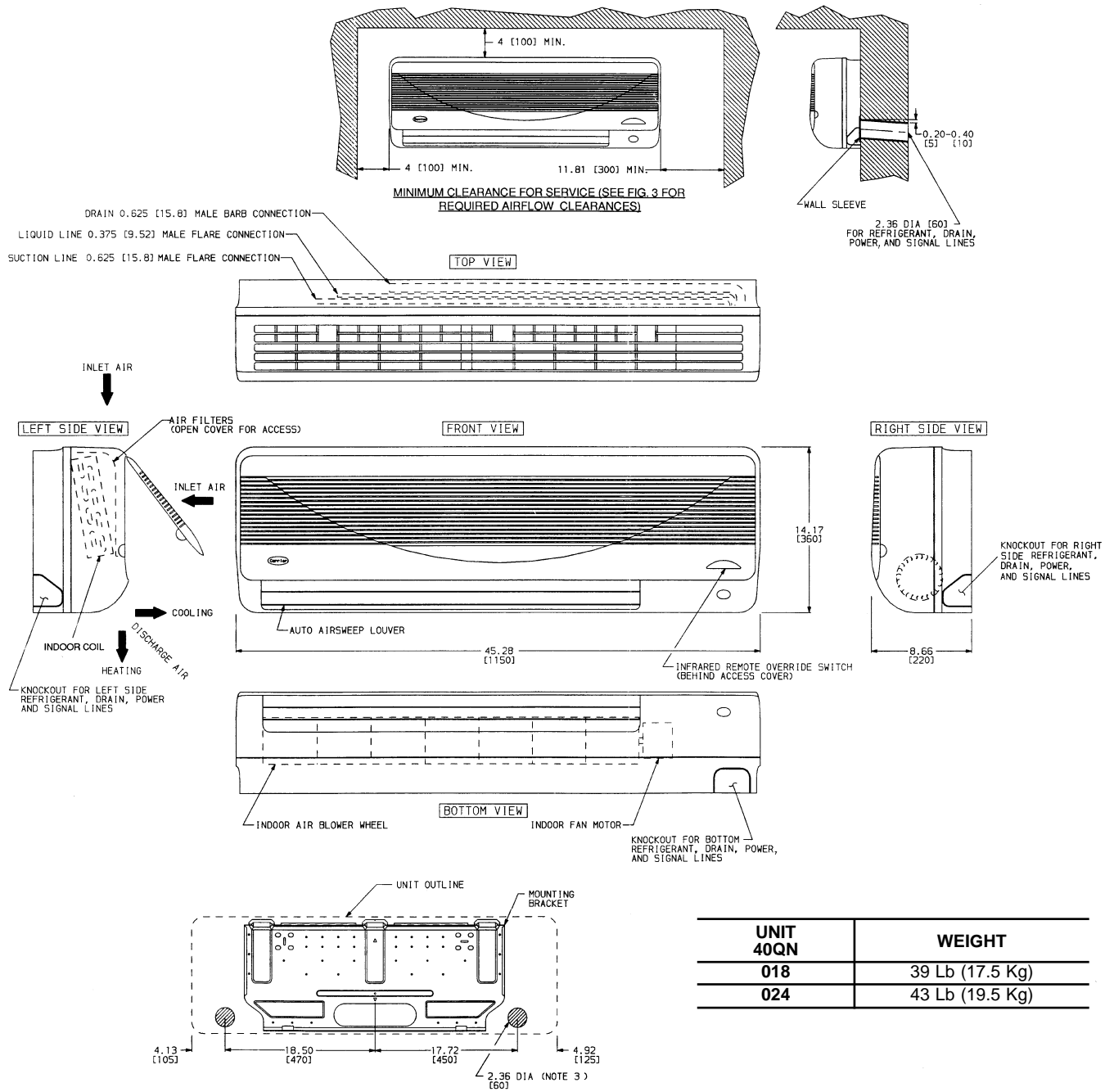

1. Dimensions in () are in millimeters.
2. Direction of airflow.
3. Refrigerant, drain, and power connections may be made in unit rear, bottom, left side, or right side.
4. Refrigerant is metered by AccuRater™ device in the fan coil unit on 38HDC, HDL and BK applications. A thermostatic expansion valve is used in the outdoor unit on 38HDS applications. Insulate both refrigerant lines on 38HDS and BK applications.
5. The 4" top and left side clearances are absolute minimums. Clearances of 10" are recommended.
6. Do not insert a trap in condensate drain line. The drain is internally trapped.

Fig. 2 — 40QN Dimensional Drawing

Table 3 — High Wall Unit Package Contents

ITEM	QUANTITY
Unit Mounting Template	1
Unit Mounting Bracket	1
1-in. Lag Screws For Unit Mounting	8
Hollow Wall Anchor Bolts For Unit Mounting	5
Wall Sleeve With Wall Cap	1
Infrared Wireless Remote Control Assembly	1
AAA Batteries (For Remote Control)	2
Remote Control Mounting Bracket	1
3/8-in. Lag Screws For Remote Mounting Bracket	2
35 ft Long High Voltage Power Wiring (2-wire with ground)	1
35 ft Long Low Voltage Thermistor Wiring (3-wire)	1
AccuRater® Body And Piston (018 and 024 Cooling Only Units)*	1
Biflow Filter Drier	1
Owner's Manual	1
Installation Instructions	1
Warranty Registration Card	1

*For heat pumps: additional heating AccuRater body and piston shipped with outdoor unit.

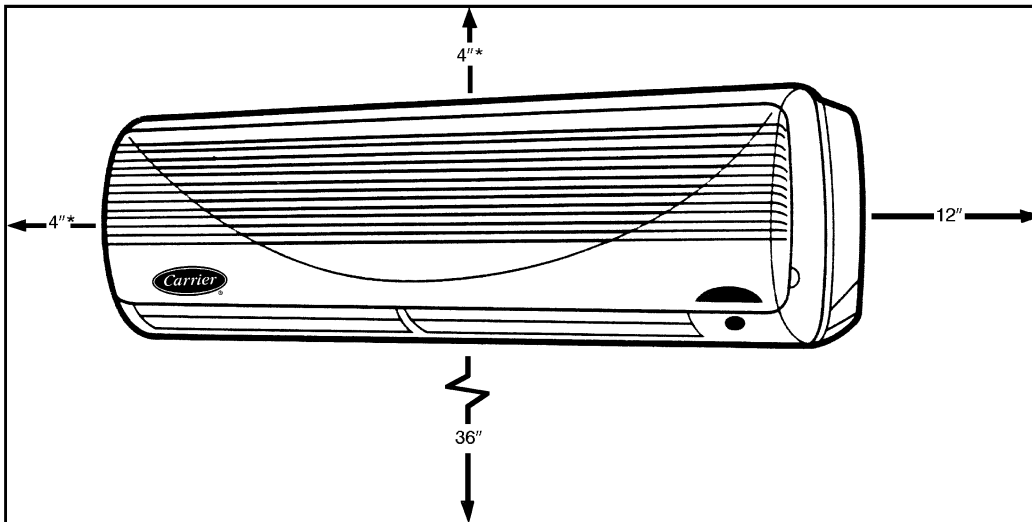

*A clearance of 4" is the absolute minimum. A clearance of 10" is recommended.

NOTE: Remove unit front cover for control box access.

Fig. 3 — Minimum Required Clearances

POSSIBLE PIPING DIRECTIONS

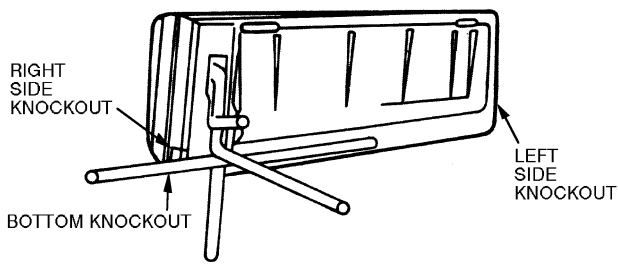

PREPUNCHED HOLES

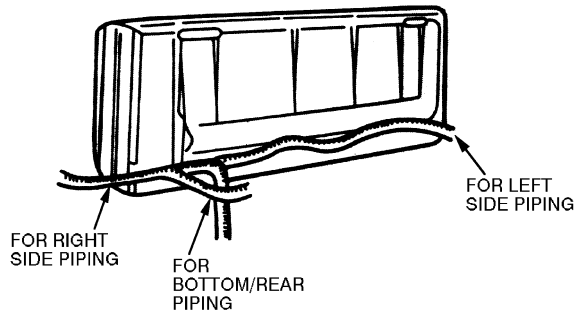
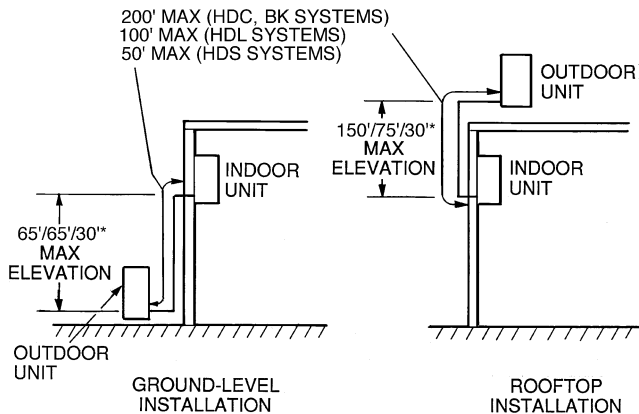

Fig. 4 — Refrigerant Piping



*38HDC, 38BK/38HDL/38HDS systems.

Fig. 5 — Maximum Line Lengths

Step 3 — Mount Mounting Bracket on Wall

1. Decide how refrigerant will be piped. If necessary, knock out the appropriate pre-punched holes (Fig. 4) on unit for piping and electrical connections.
2. Remove bracket from fan coil unit by pulling it down from fan coil unit bottom as shown in Fig. 6.
3. Using a carpenter's level, fasten mounting brackets *into the studs in the wall* at least 10 in. away from the ceiling with the 8 screws provided. Always be sure to insert screws into the top 2 holes indicated in Fig. 6. Make sure the attached bracket will support a 200 lb vertical load. For a masonry wall, anchor shields can be used to attach bracket to the wall.

4. Temporarily hang unit on bracket to check location and level.

CAUTION

If mounting bracket is not mounted level, the indoor section will be mounted unevenly, and condensate drainage water may drip onto the floor. Also, a gap between the bracket and the wall may result in vibration and noise from the indoor section.

5. Mark and cut condensate and piping holes.

- a. For piping through the wall, mark the wall below the condensate connection and cut a 2½-in. hole into the wall at either point “A” or point “B” in Fig. 7.

NOTE: The 2½-in hole must be made at a downward slope to ensure proper condensate drainage. See Fig. 8. Slope condensate line at a minimum pitch of ¼ in. per foot of line. The condensate line cannot be run up for upper piping connections – only refrigerant lines may be run up.

- b. Push the wall sleeve (factory supplied with the unit) through the 2½-in. wall opening.

Step 4 — Connect Refrigerant Piping —

Fan coil units may be connected to the outdoor units using field-supplied refrigerant grade piping. Refer to Tables 4A-4F for the correct size piping. The length of refrigerant pipe depends on the unit placement and building structure; run pipes as directly as possible. For piping requirements over 50 ft of total run, or more than 25 ft of lift, consult the long line application guidelines available in the product presale literature, or contact your local representative. For the 38HDS024 unit, the maximum pipe length is 50 ft.

CAUTION

The 40QNB,QNH unit is shipped with a factory holding charge of R-22. DO NOT BURY MORE THAN 36 IN. OF REFRIGERANT PIPE IN THE GROUND. If any section of pipe is buried, there must be a 6-in. vertical rise to the valve connections on the outdoor unit. If more than the recommended length is buried, refrigerant may migrate to the cooler, buried section during extended periods of unit shutdown, causing refrigerant slugging and possible compressor damage at start-up.

Use the following instructions to connect piping.

1. Install insulation. Insulate **all** refrigerant lines on heat pumps and 38HDS systems to prevent condensation. It is extremely important that all refrigerant lines and the AccuRater® metering device be insulated on heat pumps. On 38HDC, HDL cooling only units, the liquid line may be left uninsulated. Use any acceptable heat resistant closed-cell foam insulation (minimum ¾-in. wall thickness). When insulating piping, cap ends and slide insulation over the piping. Insulation can also be cut and placed over piping.
2. Run liquid and gas refrigerant piping.
 - a. Run pipes as directly as possible, and avoid any unnecessary turns and bends.
 - b. Suspend refrigerant pipes so that the insulation is not damaged and vibrations are not transmitted to the structure.
 - c. Leave slack in the refrigerant pipe between the structure and the unit to absorb vibrations.

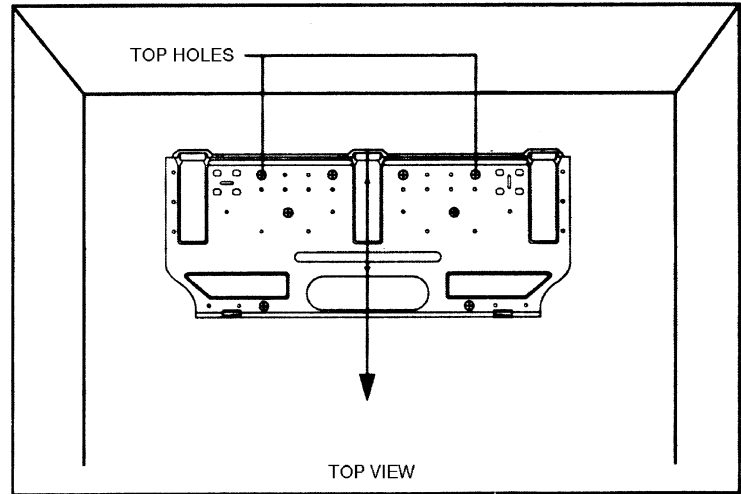
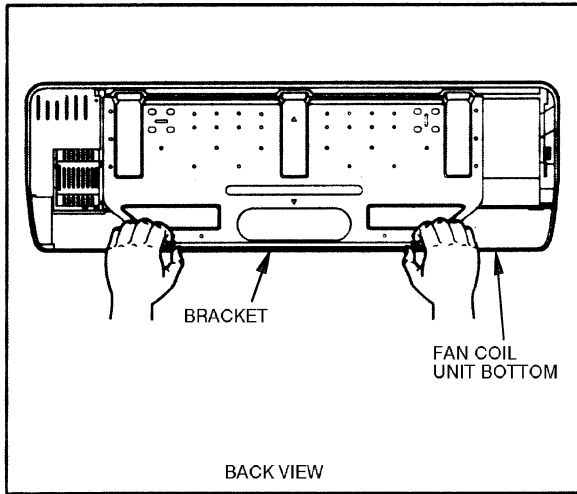
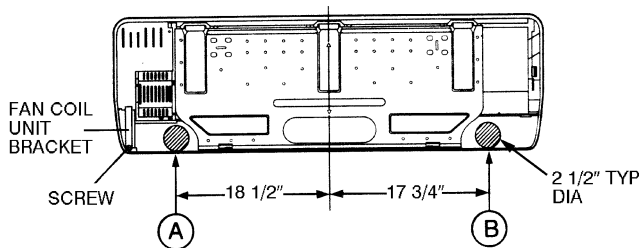

Fig. 6 — Bracket Mounting



NOTE: Use either point "A" or point "B."

Fig. 7 — Wall Hole Location for Rear Piping

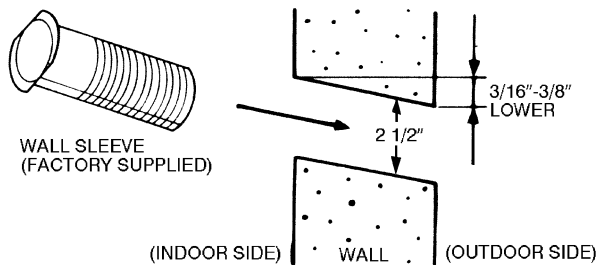

Fig. 8 — Piping Hole

d. Install factory-supplied flare connection and AccuRater metering device in liquid line at the fan coil unit on 38HDC, HDL and 38BK systems (Fig. 9). Make sure the arrow on the metering device body points **AWAY FROM** the fan coil unit. Use Table 5 to verify that the correct piston for your system has been shipped with the unit.

NOTE: No AccuRater® device is installed on 38HDS systems. The 38HDS systems have a TXV (thermostatic expansion valve) in the condensing unit for refrigerant metering and control.

e. On heat pump installations, install factory-supplied piston in the AccuRater metering device located in the service valve on the outdoor unit (Fig. 10). Make sure Teflon seal on the piston faces toward the outdoor unit. Use Table 5 to verify the correct piston for your system has been shipped with the unit. Refer to 38BK installation instructions for more details.

f. Install a liquid line filter drier near the outdoor unit (38HDC, HDL and 38BK). On heat pump systems, a bi-flow filter drier must be used. **DO NOT** install a filter drier in 38HDS systems.

3. Insulate and caulk wall openings to reduce air infiltration and refrigerant pipe vibrations on structure.
4. Evacuate piping, if necessary. If either refrigerant piping or the indoor coil is exposed to atmospheric conditions, it must be evacuated to 1000 microns to eliminate contamination and moisture in the system.

Table 4A — Physical Data — 38HDC Condensing Units

UNIT 38HDC	018	024
NOMINAL CAPACITY (Tons)	1½	2
OPERATING WEIGHT (lb)	150	154
REFRIGERANT TYPE Control (Cooling) Factory Charge (lb)	R-22 AccuRater® Piston at Fan Coil Unit 3.6	4.8
COMPRESSOR TYPE Model Oil (Recharge) (oz) Crankcase Heater (Watts) Accumulator	Tecumseh Reciprocating AW5517G 30 19 Yes	Copeland Scroll ZR23K1 25 None
OUTDOOR FAN Rpm Diameter (in.)...No. of Blades Pitch (Degrees) Motor Hp Nominal Air Cfm	Propeller, Direct Drive 850 18...3 25 ¼ 1720	850 18...3 27 ⅛ 1720
OUTDOOR COIL Face Area (sq ft)...No. of Rows Fins/in.	Copper Tube, Aluminum Fin 6.1...1.5 15	6.1...2 15
CONTROLS High-Pressure (psig) Cut-in Cutout Low-Pressure (psig) Cut-in Cutout Fusible Plug Control Voltage*	320 ± 20 426 ± 7 22 ± 5 7 ± 3 210 F 24	
REFRIGERANT LINES Connection Type Liquid Line OD (in.) Vapor Line OD (in.) Maximum Length (ft) Maximum Lift Fan Coil (Above Outdoor) (ft) Maximum Lift Fan Coil (Below Outdoor) (ft)	Sweat ¾ ¾ 200 65 150	¾ ⅝ 200 65 150

*24 v and a minimum of 40 va is provided in the fan coil unit.

Table 4B — Physical Data — 38HDL Condensing Units

UNIT 38HDL	018	024
NOMINAL CAPACITY (Btuh)	18,000	24,000
UNIT OPERATING WEIGHT (lb)	130	136
COMPRESSOR Type Model Oil (oz) Initial/Recharge	Hermetic Copeland Scroll ZR18KC-PFV 25/21	Copeland Scroll ZR24KC-PFV 25/21
OUTDOOR FAN Rpm Diameter (in.)-No. of Blades Fan Pitch (Deg) Motor Hp Nominal Airflow (cfm)	Propeller Type, Direct Drive, Horizontal 850 18-3 25 ¼ 1720	850 18-3 27 ⅛ 1720
OUTDOOR COIL Face Area (sq ft)...No. of Rows Fins per inch	Copper Tube, Aluminum Plate Fin 6.1...1 20	6.1...1.5 20
CONTROL PRESSURESTAT Low Pressure Cut-out (psig) Cut-in. (psig) Fusible Plug	Settings 7 ± 3 22 ± 5 210 F	
REFRIGERANT LINES Connection Type Maximum Length (ft) Maximum Lift (ft) — Fan Coil (Above Outdoor) Maximum Lift (ft) — Fan Coil (Below Outdoor)	Sweat 100 65 75	

Table 4C — Physical Data — 38HDS Condensing Units

UNIT 38HDS	024	048
NOMINAL CAPACITY (Tons)	2	4
OPERATING WEIGHT (lb)	159	292
REFRIGERANT TYPE Control (Cooling) Factory Charge (lb)* Circuit A Circuit B	R-22 TXV in Condensing Unit	
	5.0 —	5.5 5.5
COMPRESSOR TYPE	Copeland Scroll	
Quantity...Model Oil (Recharge) (oz)	1...ZR23K1 25	2...ZR49K3 53
OUTDOOR FAN Rpm Diameter (in.)...No. of Blades Pitch (Degrees) Motor Hp Nominal Air Cfm	Propeller, Direct Drive	
	850 18...3 27 1/8 1720	850 24...3 24 1/4 3900
OUTDOOR COIL Face Area (sq ft)...No. of Rows Fins/in.	Copper Tube, Aluminum Fin	
	6.1...2 15	12.3...2 15
CONTROLS High-Pressure (psig) Cut-in Cutout Low-Pressure (psig) Cut-in Cutout Fusible Plug Control Voltage	320 ± 20 426 ± 7 22 ± 5 7 ± 3 210 F 24	
REFRIGERANT LINES Connection Type Vapor Supply Line Quantity...OD (in.) Vapor Return Line Quantity...OD (in.) Maximum Length (ft) Maximum Lift Fan Coil (Above Outdoor) (ft) Maximum Lift Fan Coil (Below Outdoor) (ft)	Sweat	
	2...3/8 2...5/8 50 30† 30†	4...3/8 4...5/8 50 30† 30†
EXTERNAL FINISH	Alpine Mist (Beige)	

LEGEND

*Charge is based on 25 ft of interconnecting line.

†Maximum system lift is 30 ft between lowest system component and highest system component.

TXV — Thermostatic Expansion Valve

Table 4D — Physical Data — 40QNB High Wall Fan Coil Units

UNIT 40QNB	018*	024*
NOMINAL CAPACITY (Tons)	1½	2
NOMINAL SIZE (Btuh)	18,000	24,000
OPERATING WEIGHT (lb)	38.5	42.9
MOISTURE REMOVAL RATE (Pints/Hr)	5.6	6.3
FINISH	White	
REFRIGERANT Control (Cooling) System Charge Required (lb)†	R-22 AccuRater® Metering Device	
	4.6	5.3
INDOOR FAN Rpm...Cfm High Rpm...Cfm Medium Rpm...Cfm Low Motor Watts Blowers — No. ...Size (in.)	Direct Drive Centrifugal	
	1120...550 1050...500 950...450 44 2...3.94 x 17.8	1470...570 1370...466 1270...417 49 2...3.94 x 17.8
INDOOR COIL Face Area (sq ft) No. of Rows Fins/in. Circuits	Copper Tube, Aluminum Fin	
	2.56 2 15.9 2	2.56 3 18.1 3
FILTERS (Quantity) Size (in.)	Cleanable (3) 11½ x 17¾	
AIRSWEEP Horizontal Vertical	Manual Automatic	
CONTROLS Remote Controller Freeze Protection Auto. Restart Diagnostics Timer Mode Test Mode Dehumidification Mode Fan Mode Control Voltage	Integrated Microprocessor Wireless Yes Yes Yes 24-Hour Startup/Shutdown Type Yes Yes High/Medium/Low/Auto. 24 v	
REFRIGERANT LINES Connection Type Liquid Line OD (in.) Vapor Line OD (in.)	Male Flare	
	3/8 5/8	3/8 5/8
CONDENSATE DRAIN CONNECTION (in.)	5/8 OD, 7/16 ID	

*Units may only be matched with 38HDC, 38HDL and 38HDS outdoor units.

†Full factory charge shipped in outdoor unit. Charge shown is for smallest system combination and is determined based on 25 ft of line.

Table 4E — Physical Data — 38BK018, 024 Outdoor Heat Pump Units

UNIT	38BK018*	38BK024*
NOMINAL CAPACITY (Tons)	1½	2
OPERATING WEIGHT (lb)	154	167
REFRIGERANT TYPE Control (Cooling) Control (Heating) Factory Charge (lb)†	R-22 AccuRater® Piston at Fan Coil Unit AccuRater Piston at Outdoor Unit 1.5	
COMPRESSOR TYPE Model Oil (Recharge) (oz)	Tecumseh Reciprocating AW5519G 30	
CRANKCASE HEATER (Watts)	19	19
OUTDOOR FAN Rpm Diameter (in.)...No. of Blades Pitch (Degrees) Motor Hp Nominal Air Cfm	Propeller, Direct Drive 850 18...3 25 ¼ 1720	
OUTDOOR COIL Face Area (sq ft)...No. of Coils Fins/in.	Copper Tube, Aluminum Fin 6.1...1.5 15	
CONTROLS High-Pressure (psig) Cutout Cut-in Liquid Line Low-Pressure (psig) Cutout Cut-in Fusible Plug Defrost Method** Accumulator Control Voltage††	320 ± 20 426 ± 7 7 ± 3 22 ± 5 210 F Time and Temperature Defrost Yes 24 v	
REFRIGERANT LINES Connection Type Liquid Line OD (in.) Vapor Line OD (in.) Maximum Length (ft) Maximum Lift (Fan Coil Above) (ft) Maximum Lift (Fan Coil Below) (ft)	Sweat—Suction; Flare—Liquid ¾ ¾ 200 65 150	

*These units may only be used with 40QNE fan coil units.

†These units are shipped with a holding charge only.

**Demand defrost when used with 40QNE fan coil units.

††A 24-v transformer is provided in the fan coil unit; 38BK018 and 024 units have their own transformers.

Table 4F — Physical Data — 40QNH High Wall Fan Coil Units

UNIT 40QNH	018	024
NOMINAL CAPACITY (Tons)	1½	2
NOMINAL SIZE (Btuh)	18,000	24,000
OPERATING WEIGHT (lb)	38.5	42.9
MOISTURE REMOVAL RATE (Pints/Hr)	5.6	6.3
FINISH	White	
REFRIGERANT	R-22	
Control (Cooling)	AccuRater® Piston in Fan Coil	
Control (Heating)	AccuRater Piston in Outdoor Unit	
Charge Required (lb)	4.95	5.1
INDOOR FAN	Direct Drive Centrifugal	
Rpm/Cfm High	1120/530	1470/570
Rpm/Cfm Medium	1050/490	1370/466
Rpm/Cfm Low	950/430	1270/447
Motor Watts	42.3	49
Blowers Quantity...Size (in.)	2...3.94 x 17.8	2...3.94 x 17.8
INDOOR COIL	Copper Tube, Aluminum Fin	
Face Area (sq ft)	2.56	2.56
No. of Rows	2	3
Fins/in.	15.9	18.1
Circuits	2	3
FILTERS	Cleanable	
Quantity...Size (in.)	2...11½ x 17¾	
AIRSWEEP	Manual	
Horizontal	Automatic	
Vertical		
CONTROLS	Integrated Microprocessor	
Remote Controller Options	Wireless	
Diagnostics	Yes	
Defrost Method	Demand Defrost	
Timer Mode	Yes	
Warm Start Feature	Yes	
Test Mode	Yes	
Freeze Protection	Yes	
Dehumidification	Yes	
Auto. Changeover	Yes	
Fan Mode	High/Medium/Low/Auto.	
Auto Restart	Yes	
Control Voltage	24 v (provided)	
REFRIGERANT LINES	Flare	
Connection Type	¾	
Liquid Line OD (in.)	5/8	
Vapor Line OD (in.)	5/8	
CONDENSATE DRAIN CONNECTION (in.)	5/8 OD, 7/16 ID	

*Outdoor unit is shipped with a holding charge. The amount of the charge is determined based on 25 ft of line.

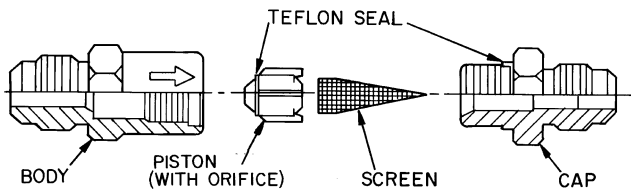

NOTE: Arrow on AccuRater® body points in free flow direction away from the coil.

Fig. 9 — AccuRater Metering Device in Liquid Line (Bypass Type Components); Cooling

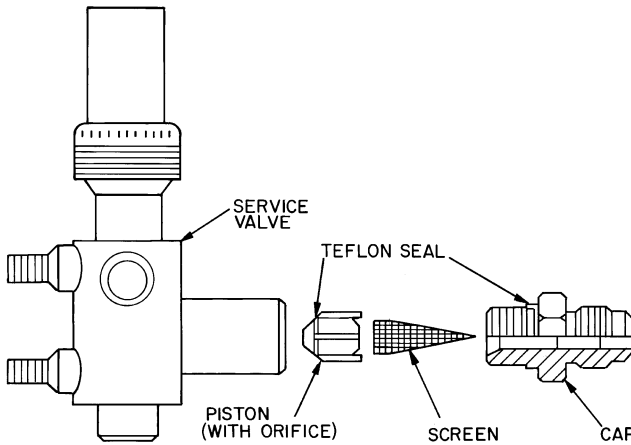

Fig. 10 — AccuRater Metering Device at Service Valve (Bypass Type Components); Heating

Step 5 — Connect Condensate Drain Line —
Observe all local sanitary codes when installing condensate drains.

1. Connect drain line by inserting a 5/8-in. rigid PVC pipe over the drain connection. Refer to Fig. 11.

CAUTION

The drain tube extension must be securely fastened to the condensate drain. Failure to do so can result in condensate water dripping onto the floor.

2. To ensure regular flow of condensate water, the drain pipe should be pitched toward an open drain or sump at a downward slope of at least 1/4-in. per foot. Refer to Fig. 12.

IMPORTANT: Be sure the drain piping has no slack which might form a trap. Do not insert a trap in the drain line; the drain is internally trapped.

3. Insulate condensate drain line(s). Insulate the condensate drain lines that are located in or above an occupied area with a condensate proof material such as polyurethane or neoprene.

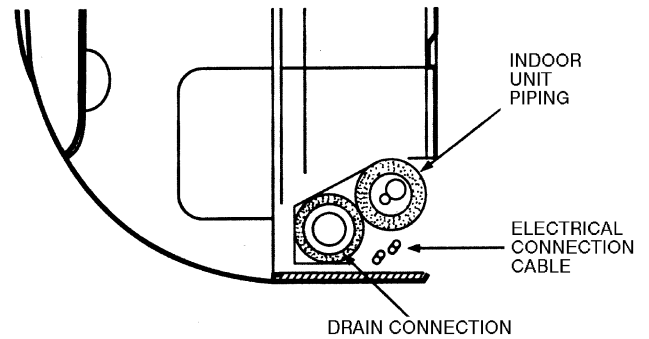

Fig. 11 — Drain Connection (Right Side Shown When Facing Fan Coil Unit)

Table 5 — Required Piston Sizes for AccuRater Metering Device

OUTDOOR UNIT 38	INDOOR UNIT 40QN	INDOOR PISTON	INDOOR PISTON TYPE	OUTDOOR PISTON	OUTDOOR PISTON TYPE	REQUIRED SYSTEM CHARGE (lb)*
HDC, HDL018	B018	49	B	N/A	N/A	4.6
HDC024	B024	57	B	N/A	N/A	5.3
BK018	H018	51	B	47	B	5.0
BK024	H024	59	B	52	B	5.1

LEGEND

N/A — Not Applicable
TXV — Thermostatic Expansion Valve

*Charge amount determined based on 25 ft of line. Check charge for longer lines using superheat method. See 38HDC, HDL and BK installation, start-up, and service instructions for system charging procedures.

NOTE: The 38HDS systems do not use the AccuRater device. The 38HDS systems have a TXV in the condensing unit for refrigerant metering and control.

Step 6 — Make Electrical Connections — Be sure field wiring complies with local building codes and NEC, and unit voltage is within limits shown in Table 6. Refer to Table 7 for units with electric heat.

Contact local power company for correction of improper line voltage.

⚠ WARNING

To avoid personal injury or damage to unit, do not make electrical connections until all power sources are shut down, locked out, and tagged off. Failure to do so could result in personal injury or unit damage.

⚠ CAUTION

Operation of unit on improper line voltage constitutes abuse and could affect warranty. Refer to Table 6 for permissible operating limits. Do not install unit in system where voltage may fluctuate above or below permissible limits.

NOTE: Use type NM power cable only (per NEC; provided for fan coil units only) between disconnect switch and unit.

NOTE: Install branch circuit disconnect per NEC of adequate size to handle unit starting current. Locate disconnect within sight from and readily accessible from unit, per Section 440-14 of NEC. Some codes allow indoor unit to share disconnect with outdoor unit if disconnect can be locked; check local code before installing in this manner. To make electrical connections:

1. Remove the screws holding the front cover of the fan coil unit, and remove front cover. Save screws and screw covers for reinstallation.

2. Remove control box strain relief clamp (see Fig. 13).
3. Remove any factory test leads still connected to the power terminal box. These leads (if applicable) are for factory testing only and cannot be used for power connections.
4. Route the factory-supplied ground and power wires from terminal block 1 (TB1) to the field-supplied disconnect switch.

⚠ WARNING

According to NEC and most local codes, the unit must have an uninterrupted, unbroken ground to minimize personal injury if an electrical fault should occur. The ground may consist of electrical wire or metal conduit when installed in accordance with existing electrical codes. Failure to follow this warning could result in an electric shock, fire, or death.

5. Route factory-supplied line power leads (see Fig. 14) from field-supplied, indoor unit disconnect to the fan coil unit TB1 (see Fig. 14 and 15). Run wire through the strain relief on the control box (see Fig. 13). When routing wire in the fan coil unit, keep the wire away from refrigerant and condensate piping and any sharp edges on the unit.

⚠ CAUTION

Do not short circuit the 40QN transformer – it is fused. The transformer can be short circuited by connecting the wrong wires or by touching a live wire to the side of a grounded control box.

Table 6 — Electrical Data

INDOOR UNIT 40QN	V (Single-Ph, 60 Hz)	OPERATING VOLTAGE*		FAN		WATTS	MCA	MAX FUSE OR HACR TYPE CKT BKR AMPS
		Max	Min	LRA	FLA			
B018	208/230	253	187	3.2	0.53	94	10.9	15
B024								
H018								
H024								

LEGEND

- FLA — Full Load Amps
- HACR — Heating, Air Conditioning, and Refrigeration
- LRA — Locked Rotor Amps
- MCA — Minimum Circuit Amps per NEC Section 430-24
- NEC — National Electrical Code

*Permissible limits of the voltage range at which unit will operate satisfactorily.

Table 7 — Electric Heater Data

INDOOR UNIT	VOLTS-Ph (60 Hz)	INPUT AMPS	kW AT 230 V	MIN WIRE SIZE (AWG)
40QNH018	230-1	7.8	1.8	14
40QNH024	230-1	7.8	1.8	14

LEGEND

- AWG — American Wire Gage

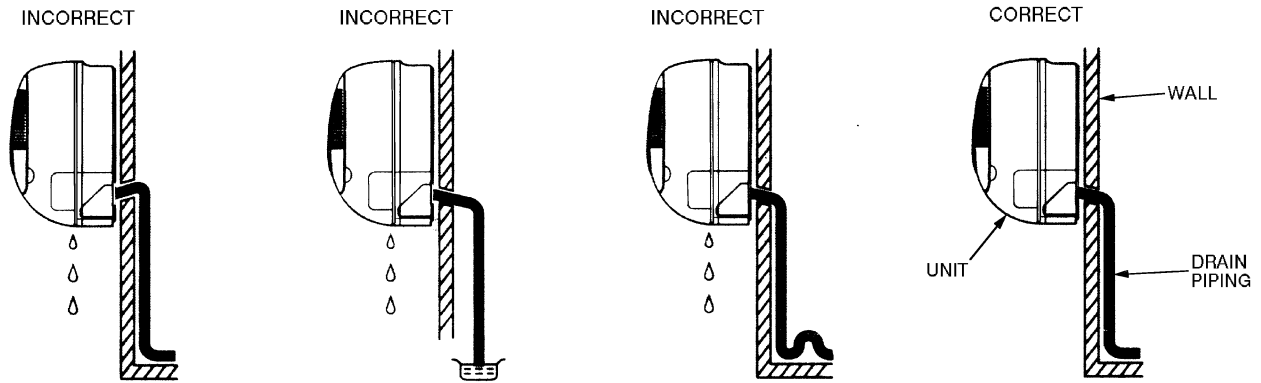

Fig. 12 — Drainage System (Rear Piping Shown)

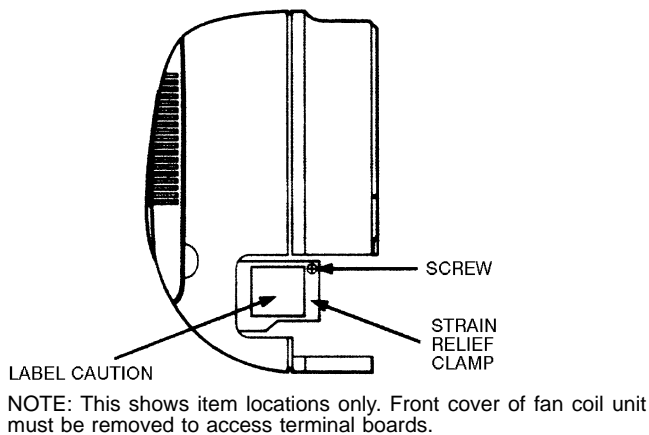

Fig. 13 — Fan Coil Unit Wiring Preparation

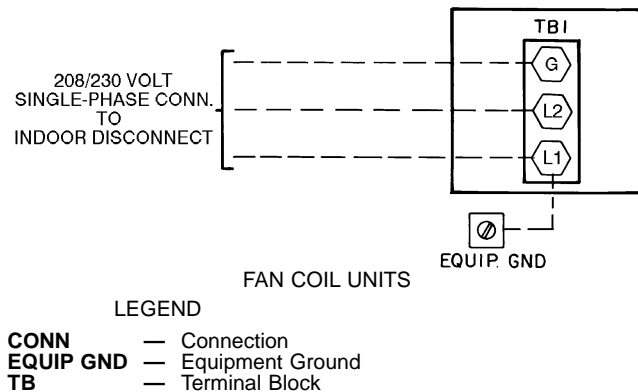

Fig. 14 — Line Power Connections

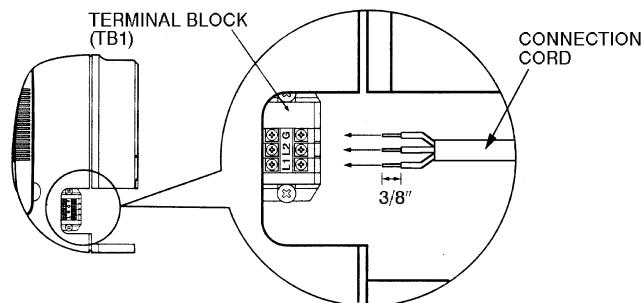

Fig. 15 — High Voltage Connections

Step 7 — Make Connections to the Outdoor Unit

COOLING-ONLY SYSTEMS — To connect the 38HDC, HDL or HDS condensing unit to the fan coil unit(s) so that the system will operate correctly:

Route 2 field-supplied wires of 18-gage AWG (American Wire Gage) thermostat cable between the low-voltage terminal block of the fan coil unit (TB2) and the 38HDC, HDL or HDS unit low-voltage terminal block. Connect the wires between terminals Y and Y and between terminals C and C.

HEAT PUMP SYSTEMS — To connect the 38BK heat pump unit to the fan coil unit so that the system will operate correctly:

IMPORTANT: DO NOT RUN THE THERMISTOR CABLE IN THE SAME CONDUIT AS THE POWER WIRING.

1. One thermistor connection cord with a lead length of 24 ft is shipped with the 40QNH fan coil unit. Run the connection cord from the low-voltage terminal board in the control box in the fan coil unit (TB3) to the heat pump unit. Route the wire carefully so that it will not be damaged.
2. For cooling operation, route 2 field-supplied wires of 18-gage AWG (American Wire Gage) thermostat cable between the low-voltage terminal block of the fan coil unit (TB2) and the 38BK unit low-voltage terminal block. Connect the wires between terminals Y and Y and between terminals C and C.
3. For heating operation, route 3 additional wires of 18-gage AWG thermostat cable between the low-voltage terminal block of the fan coil unit (TB2) and the 38BK unit low-voltage terminal block. Connect the wires between terminals R and R, O and O, and G and G.

Step 8 — Install Fan Coil Unit Onto Mounting Bracket

1. Hook the fan coil unit onto the top of the mounting bracket. See Fig. 16.
2. Snap the fan coil unit onto the mounting bracket as shown in Fig. 16.

IMPORTANT: An audible snapping sound will be heard as the hook on the unit is secured into the hole on the mounting bracket. Be sure unit is correctly mounted.

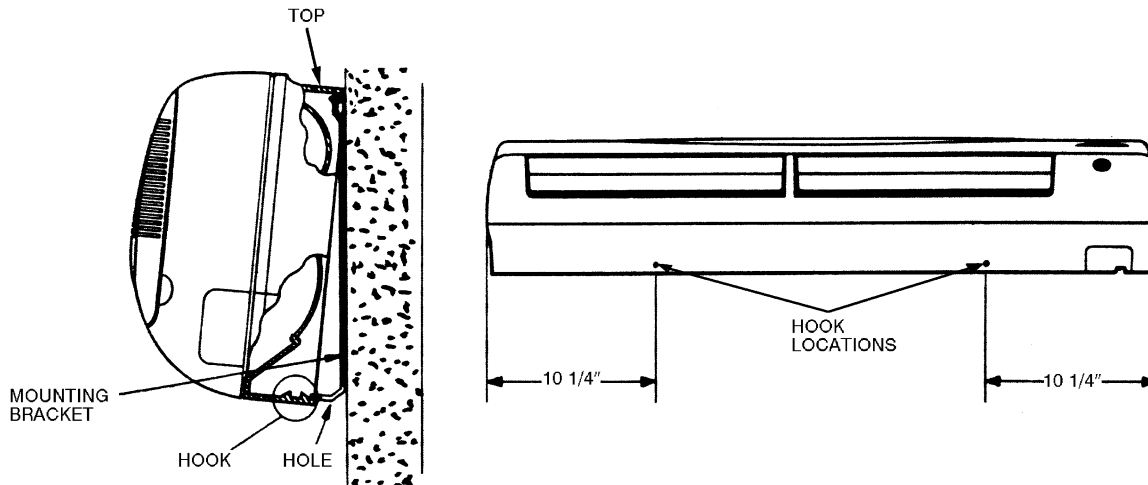

Fig. 16 — Mounting Unit to Bracket

START-UP

Complete the following checks and the Start-Up Checklist on page CL-1 before system start-up. Refer to outdoor unit installation, start-up and service instructions for system start-up procedures and refrigerant charging methods.

1. Check condensate drainage system.
Add water to check the drainage flow. If water does not flow regularly, check the pipe slope or see if there are any pipe restrictions.
2. Make sure that all wiring connections are correct and tight.
3. Make sure that all barriers, covers, and panels are in place.
4. Ensure that the filters have been installed and that the discharge louvers are correctly positioned.

⚠ WARNING

Never operate unit without a filter. Damage to the unit or personal injury may result.

5. If the unit is equipped with a crankcase heater, energize a minimum of 24 hours before starting the unit. To energize crankcase heater only, close indoor unit disconnect, then with the remote controller, set unit in off mode and close the outdoor unit disconnect.
6. Fully backseat (open) the liquid and vapor tube service valves.
7. Unit is shipped with valve stems frontseated and caps factory installed. Replace stem caps after system is opened to refrigerant flow (backseated). Replace caps finger tight.
8. With the remote controller, turn on the unit and operate in each mode (as applicable) for 15 minutes to test for proper operation. Do not operate in cooling mode if outdoor temperature is below 55 F (HDC, HDL, BK) or 0° F (HDS) unless unit is equipped with low ambient control (HDC, HDL, BK) or winter start kit (HDS). Do not operate in heating mode (heat pump systems only) if the outdoor temperature is above 75 F.
9. Test for proper refrigerant charge using the superheat method (HDC, HDL, BK) or subcooling method (HDS).
10. Explain basic system operation to the owner.

40QN Control System — The 40QN unit is equipped with a microprocessor control which operates the system. This control is located in the control box of the fan coil unit, with thermistors located in the fan coil inlet and on the

indoor coil. The 40QNH heat pump fan coil units also have thermistors located on the outdoor coil and in the outdoor air inlet. These thermistors monitor system operation and control the operating mode. To change settings or modes of operation, use the factory-supplied infrared wireless remote controller. This controller allows the fan coil unit to be operated from within the same room without any wire connections to the unit.

WIRELESS REMOTE CONTROLLERS — A wireless remote controller is supplied for system operation of all high wall units. Each battery-operated wireless (infrared) remote controller may be used to control more than one unit. The wireless remote controller has a maximum range of 20 feet. The fan coil unit is equipped with an emergency switch which allows operation if the remote controller malfunctions or is misplaced. Because the controller uses infrared communication, all of the following must be true for the controller to work properly:

1. The power must be on to the fan coil unit.
2. The batteries in the controller must be good.
3. The controller must be within range of and pointed directly at the fan coil unit.
4. The fan coil unit's 3-position switch must be set in the remote position.

The remote controller includes a wall-mounted bracket. To install the bracket, attach bracket to the wall as shown in Fig. 17 using, double-sided tape included in remote controller assembly. Install factory-supplied batteries into the remote controller per To Install or Replace Remote Controller Batteries section on page 18, and place the controller into the bracket so that it will be ready for use.

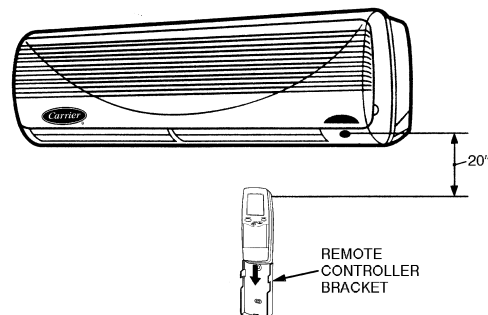

Fig. 17 — Mounting Remote Controller Bracket

After Extended Shutdowns — If the system has been turned off for more than 12 hours, turn on the indoor and outdoor unit disconnect switches to supply power to the system for 12 hours BEFORE starting the system.

Seasonal Changeovers — When changing heat pump system from cooling to heating or heating to cooling, or before starting cooling only system after it has been out of use for the winter season, perform the following steps BEFORE starting the system:

1. Inspect and clean the outdoor unit, particularly the coil.
2. Clean or replace the air filters in the indoor unit.
3. Clean the indoor unit drain pan and drain pipe, and remove any obstructions.
4. Turn on indoor and outdoor unit disconnect switches to supply power to the system 12 hours before starting the system.

To Turn the Unit On and Off — To turn the unit on, press the orange ON/OFF button (See Fig. 18). Unit will start. To stop unit operation, press the ON/OFF button again. Unit will stop. Refer to Owner's Manual enclosed with the fan coil unit for full remote control operating details.

Adjusting Airflow — The airflow direction may be adjusted up and down using the remote controller, and from side to side by manually moving the vents. For cooling only units and heat pump units when in the cooling mode, set the louvers to discharge straight out (parallel to the floor) (see Fig. 19). For the heat pump units operating in heating mode, it is recommended that the air discharge louvers be set to discharge vertically (see Fig. 19).

The swing range shown in Fig. 19 is the range which will provide maximum occupant comfort in each mode. It is recommended that the louvers be positioned within this range (using the remote controller).

NOTE: The full swing range for the mode selected will automatically be used if auto. fan mode is selected.

Operating Mode Memory — After the system is turned off or after a power failure, the system remains in the last operating mode selected. When the system is turned back on, or when power is automatically restored, operation continues in the same operating mode as when power shut down.

Automatic Operation (Auto) Mode — If auto mode is selected, the system automatically switches the operating mode from heating (heat pump system only) to cooling, or from cooling to heating (heat pump system only) depending on the selected temperature.

NOTE: Between the cooling cycle and the heating cycle there is a neutral zone of approximately 2° F above and 2° F below the selected temperature when only the fan is operating.

Operating Fault Diagnosis — The system includes an automatic diagnosis feature which is activated under difficult or unacceptable operating conditions. If such conditions occur, the system stops automatically, the operating fault signal appears (green "UNIT ON" light on the front of the fan coil unit flashes), and an analysis of the system operating conditions is initiated. The system will then be restarted automatically, as soon as normal conditions have been restored, or it will remain off. If the system does not start again, the green "UNIT ON" light will flash an error code.

Microprocessor Control Operation — This system is controlled by a microprocessor designed to give optimum levels of comfort and operating efficiency. The control is located in the 40QN unit. To operate the unit, the factory-supplied remote controller is required.

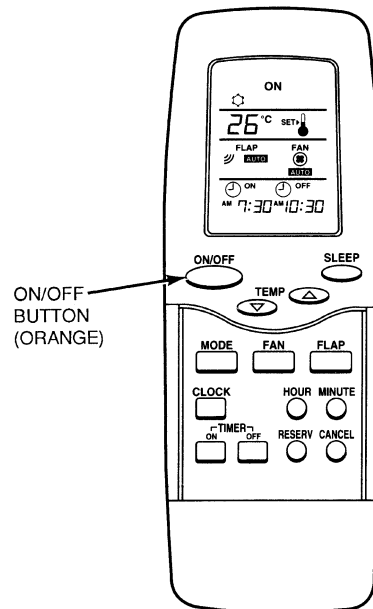
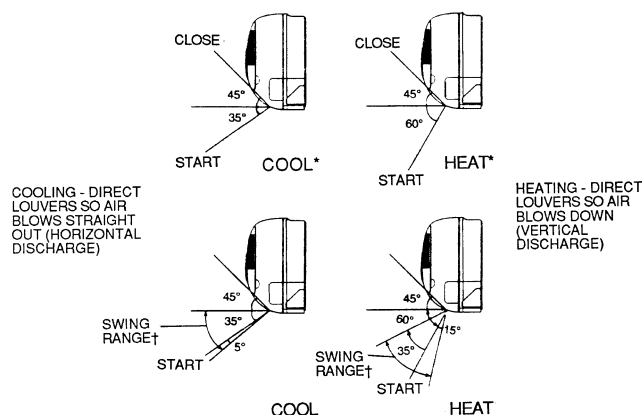

Fig. 18 — Remote Controller



*Potential range.
†Desirable range.

NOTE: Unit is equipped with manual air vents which direct the air from side to side. Up and down louver motion can be selected using the remote controller. For maximum comfort, set louvers within the swing range. See Adjusting Airflow section on this page for more information.

Fig. 19 — Louver Adjustments

There are 9 (QNB systems) or 12 (QNH systems) operating modes (including the off mode) for the unit. Each mode operates as follows:

- Off Mode — When the unit is in the Off mode, all functions (compressor, outdoor fan, indoor fan, and air sweep) are off, except the reversing valve (QNH only), which will stay energized if the unit was last operated in the Cooling mode.
- Air Circulation Mode (Fan Operation Only) — When Air Circulation mode is selected, the indoor fan will operate continuously in the selected speed (high, medium, low, or Auto.). If the Auto. mode is selected, the indoor fan will operate at low speed. The compressor and outdoor fan are off. The reversing valve (QNH only) will remain in the last operating mode.

- **Cooling Mode** — When the Cooling mode is selected, the indoor fan will operate continuously at the selected speed if the speed is high, medium, or low. If the indoor fan is in Auto. mode, the fan will change operating speeds depending on the difference between the room temperature and the set point. The reversing valve (QNH only) will be energized. The compressor cannot run for 3 minutes from the time the system starts up or for 3 minutes from the time the compressor last operated. When the temperature of the room is equal to or greater than the selected temperature, the compressor and outdoor fan will operate until the room temperature is 2° F below the set point, and then shut off. When the room temperature is less than the selected temperature, the compressor and outdoor fan remain off.
- **Maximum Dehumidification Mode** — When the Dehumidification mode is selected, the indoor fan will operate continuously at the selected speed if the speed is high, medium, or low. If the indoor fan is in Auto. mode, the fan will change operating speeds depending on the room temperature. If the room temperature is below the set point, the indoor fan will run at ultra-low speed, and the compressor could run for up to 4 minutes. (Ultra-low speed is a control-driven speed [not user configurable] used to sample the space when the fan would normally be off.) The reversing valve (QNH only) will be energized. The compressor cannot run for 3 minutes from the time the system starts up or for 3 minutes from the time the compressor last operated.

Initial Operation — When the mode is first selected, one of the following occurs:

1. If the room temperature is above or equal to the selected temperature, the unit will operate for 16 minutes, and the compressor and outdoor fan will operate. The indoor fan will operate as in the Cooling mode. After 16 minutes of operation (or when the room reaches 2° F below set point), the unit switches to normal dehumidification operation.
2. If the room temperature is below the selected temperature, the unit will operate for 8 minutes as follows: the compressor and outdoor fan will operate for 3 minutes. The indoor fan will operate in low speed, and 30 seconds after the compressor stops, the indoor fan stops. The unit remains off for 1 minute, and then the indoor fan starts in ultra-low speed for 30 seconds. The unit then switches to normal dehumidification operation.

Normal Operation — One of the following will take place:

1. When the temperature of the room is equal to or greater than the selected temperature (by not more than 3° F), the unit will operate for 8 minutes as follows: the compressor and outdoor fan will operate for 3 minutes. The indoor fan will operate in low speed, and 30 seconds after the compressor stops, the indoor fan stops. The unit remains off for 1 minute, and then the indoor fan starts in ultra-low speed for 30 seconds. The normal dehumidification operation is repeated for the newly sensed room temperature.
2. If the room temperature is equal to or greater than the selected temperature, but not by more than between 4° F and 6° F, the compressor and outdoor fan operate for 4 minutes. The indoor fan will run at ultra-low speed and will stop 30 seconds after the compressor stops. After 3 minutes, the indoor fan runs at ultra-low speed for 30 seconds. The normal dehumidification operation is repeated for the newly sensed room temperature.

3. When the room temperature is equal to or greater than 4° F below the selected temperature, the system operates as follows: The compressor and outdoor fan operate for 3 minutes. The indoor fan will operate at ultra-low speed and will stop 30 seconds after the compressor stops. After 4 or 5 minutes, the indoor fan starts in ultra-low speed for 30 seconds. The normal dehumidification operation is repeated for the newly sensed room temperature. If the room temperature is still 4° F below the selected temperature, the compressor, outdoor fan, and indoor fan remain off. After 7½ minutes, the indoor fan operates at ultra-low speed for 30 seconds. The normal dehumidification operation is repeated for the newly sensed room temperature.

- **Heat Pump Heating Mode (Heat Pump Systems Only)** — When the Heat Pump mode is selected, the indoor fan will operate at the selected speed if the speed is high, medium, or low, unless overridden by the coil temperature (to prevent cold drafts). If the indoor fan is in Auto. mode, the fan will change operating speeds depending on the difference between the room temperature, the set point, and the coil temperature. The reversing valve will be deenergized. The compressor cannot run for 3 minutes from the time the system starts up or for 3 minutes from the time it last operated. When the temperature of the room is 8° F below the selected temperature, the unit will operate in Heat Pump mode until the temperature is 6° F above the selected temperature, or the compressor runs for 40 minutes (whichever comes first). If the temperature of the room is less than 7° F below or equal to the selected temperature, the unit operates in Heat Pump mode until the selected set point temperature plus 2° F is reached.

- **Electric Heat in Heat Pump Heating Mode** — Supplemental electric heat is enabled when the outside air thermistor located in the outdoor unit is below 40 F and the room temperature thermistor is equal to or less than 5.4 F below set point. Electric heat will remain on until 1.8° F above set point, then will turn off. Fan operation will be the same as described previously in the heat pump heating mode.

NOTE: Electric heat control cannot be overridden.

- **Demand Defrost Mode (Heat Pump Systems Only)** — This unit uses a demand defrost system to remove frost from the outdoor coil during heating operation. The indoor and outdoor fans are shut off during Defrost mode. See Fig. 20. For high wall heat pump units, the electric heat is OFF during Defrost mode.

- **Sleep Mode** — The Sleep mode timer turns the unit off when the timer reaches zero minutes. The durations that can be selected are 1, 2, 3 or 7 hours. After the initial 30 minutes, the user set point shifts approximately 1° F warmer. This sequence repeats itself every 40 minutes up to a total of 150 minutes. When Sleep mode is enabled, the display on the remote controller is dimmed.

- **On/Off Timer Mode** — The on/off timer will turn the unit on or off at a user selectable on and off time (this is one time event only). The unit will start in the same mode and at the same selected temperature as when the system shut off. If the room temperature is not within approximately 5° F of the set point 40 minutes before start-up, the unit runs before the user selected on time is reached to achieve the set point temperature at start-up.

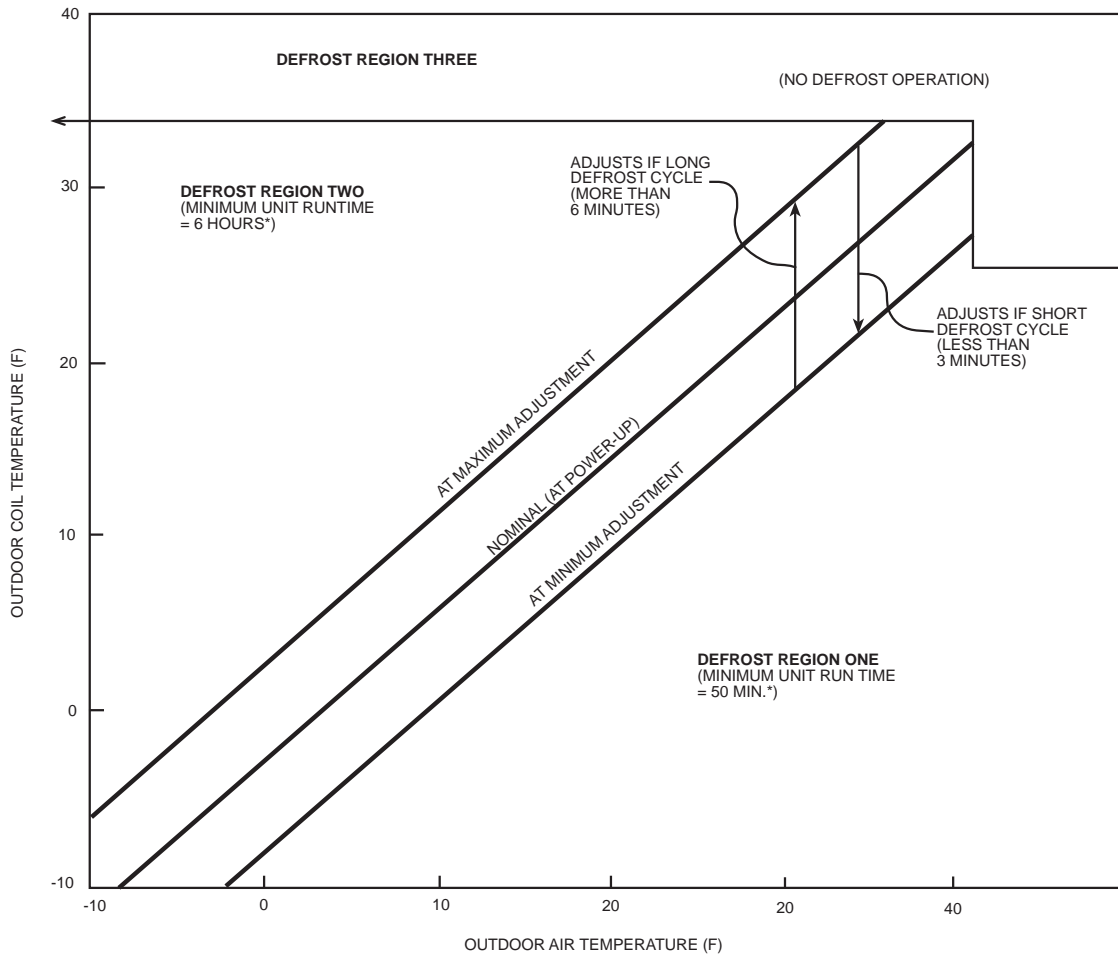

*A defrost will be initiated after 30 minutes of compressor run time if the outdoor coil temperature is less than -4° F.

Fig. 20 — Electronic Control Defrost Regions Map

- Automatic Operation Mode for Cooling Only Systems (38HDC, HDL, and HDS) — The unit samples the air in the room. Based on the room temperature, the unit selects one of the following modes:

1. Cooling Mode — If the room temperature is more than 82.4 F with a preset temperature of 78.8 F.
2. Dry Mode — If the room temperature is more than 75.2 F and less than 82.4 F with a preset temperature of 77 F.
3. Fan Only Mode — If the room temperature is less than 75.2 F.

The preset temperature can be changed by $\pm 4^{\circ}$ F using the remote control.

- Automatic Operation Mode for Heat Pump Systems (38BK) — The operation mode will be determined after 20 seconds of room monitoring (to determine the room temperature and the outdoor air temperature).

- Test Mode — The test mode can be selected by setting the slide switch on the fan coil unit to TEST position. The slide switch is located on the front of the unit as shown in Fig. 21. The fan coil unit will start immediately (there is no compressor time delay when using Test mode) in Cooling mode with an infinitely low set point. The indoor fan speed will be at the high setting, and the swing louvers will be on (moving up and down).

NOTE: The unit cannot be controlled by the remote controller until the slide switch is returned to the REMOTE position.

- Emergency Mode — This mode is only to be used if the remote controller is lost, damaged, or the batteries are discharged. To initiate Emergency mode, manually move the slide switch on the fan coil unit to the EMER position (Fig. 21). The unit is automatically operated in Cooling or Heating (BK units only) mode according to room temperature. Emergency operation settings are as follows:

1. Operation mode: AUTO.
2. Fan Speed: AUTO.
3. Cooling set point: 77 F
4. Timer Mode: Continuous

NOTE: The unit cannot be controlled by the remote controller until the slide switch is returned to the REMOTE position.

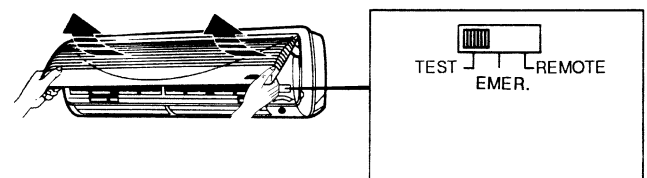

EMER — Emergency Mode

Fig. 21 — Slide Switch

CLEANING AND MAINTENANCE

⚠ CAUTION

To avoid the possibility of electric shock, before performing any cleaning and maintenance operations, always turn off power to the system by pressing the orange ON/OFF button on the remote controller. Turn off the outdoor disconnect switch located near the outdoor unit. If the indoor unit is on a separate switch, be sure it is also disconnected.

For proper system operation, perform the cleaning and maintenance operations in Table 8.

Lubrication — The indoor-fan automatic air sweep motor, and the outdoor-fan motor are factory lubricated and require no oiling.

To Install or Replace Remote Controller Batteries

⚠ CAUTION

Do not drop the remote controller — damage to the device may result. Avoid getting the controller wet.

NOTE: Before replacing the batteries, note that the remote controller signal can be affected if electronic fluorescent lights are installed nearby. The batteries may not need to be

replaced. If you suspect this is the problem, consult your Carrier distributor.

Batteries should be replaced once a year. Use 2 batteries (1.5 v, dc-type, AAA alkaline batteries). Never use old or recharged batteries together with new ones.

To replace batteries:

1. Slide the battery cover off from the back of the remote controller. See Fig. 22.
2. Insert the 2 batteries in accordance with the markings on the remote controller, so that the poles are correct (+ and -).
3. Press the **RST** button using an instrument screwdriver or similar small, pointed tool.
4. Replace the cover securely.

It is time to replace the remote controller batteries when the remote controller function becomes irregular, or the system no longer responds to commands given close to the unit.

When shutting down the system for an extended period of time, it is advisable to *remove* the batteries.

Consult distributor if any other equipment is turned on or shows signs of disrupted operation if you use the wireless remote controller, or if the system is turned on or shows signs of disrupted operation when the remote controller of any other equipment is used.

Table 8 — Cleaning and Maintenance Schedule

TASK	MONTHLY	QUARTERLY	YEARLY
INDOOR UNIT			
Clean Air Filters	X		
Clean Drain Pipe		X	
Clean Condensate Drain Pan			X
Replace Batteries in the Remote Controller			X
Clean Indoor Unit Front Panel		X	
OUTDOOR UNIT			
Clean the Fins From Outside		X	
Open the Unit and Clean Fins Inside			X
Remove Dust From Electrical Parts			X
Check Electrical Connections are Tight			X
Clean Outdoor Fan			X
Check that Outdoor Fan Assembly is Tight			X
Clean Drain Pan		X	

NOTE: Maintenance procedures for the outdoor unit are in the 38HDC, HDL, HDS, and BK installation instructions.

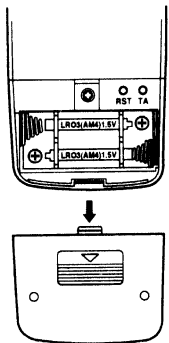

REMOVE COVER

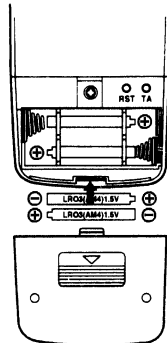

INSERT NEW BATTERIES

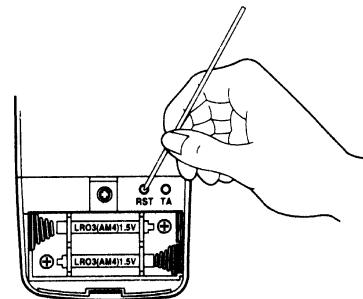

PRESS **RST**

NOTE: Be sure to insert new batteries correctly (as shown).

Fig. 22 — Installing or Replacing Batteries

To Set the Current Time

1. Press the **TA** button (located on the back of the remote controller; see Fig. 23) with an instrument screwdriver or similar small, pointed tool, and the current time indication symbol flashes.

Note that the controller comes preset from the factory set for 6:00 a.m.

2. Set the current time with the hour and minute buttons on the front of the remote controller (see Fig. 22) while the current time indication is flashing. Note that a.m. and p.m. are also indicated as the times are scrolled through.
3. Press **TA** again. The flashing will stop and the current time will be reset to the new setting.

To Remove and Clean or Replace Air Filters

CAUTION

Operating your system with dirty air filters may damage the indoor unit and can also cause reduced cooling performance, intermittent system operation, frost build-up on the indoor coil, and blown fuses. Inspect and clean or replace the air filters *monthly*.

TO REMOVE AIR FILTERS

1. Open fan coil unit front panel (lift). See Fig. 24.
2. Pull the filters down to remove.

TO CLEAN OR REPLACE FILTERS — Filters should be vacuumed and washed with warm water (see Fig. 24). Shake filter to remove any excess water, dry thoroughly, and replace by sliding filter behind front grille until filter snaps in place.

If the filter has begun to break down or is torn, it needs to be replaced. Replacement filters are available through your Carrier distributor.

To Clean Indoor Unit Front Panel — If the front panel of the unit becomes dirty or smudged, wipe the outside of the front panel with a soft dry cloth. If necessary, use a mild liquid detergent and wipe off carefully with a dry cloth.

CAUTION

When cleaning the front panel, NEVER use water hotter than 105 F, and DO NOT pour water onto the fan coil unit. Do not use abrasive or petroleum-based cleaners — damage to unit appearance will result.

To Clean Indoor Coil — To clean the coil, remove indoor unit front panel, and vacuum the coil fins. Use care not to bend or damage fins.

To Clean Outdoor Coil (Outdoor Unit)

WARNING

Some metal parts and sharp fins of outdoor unit coil can cause personal injury during cleaning. Clean coil carefully.

To clean the outdoor coil:

1. Remove any dirt or obstruction from discharge opening.
2. Use a garden hose to spray water on the coil. Debris that collects between coil fins inhibits heat transfer — direct the water spray between coil fins to flush out debris.

Cleaning Condensate Drains — Clean all drains and drain pans at the start of each cooling season. Check the flow by pouring water into the drain.

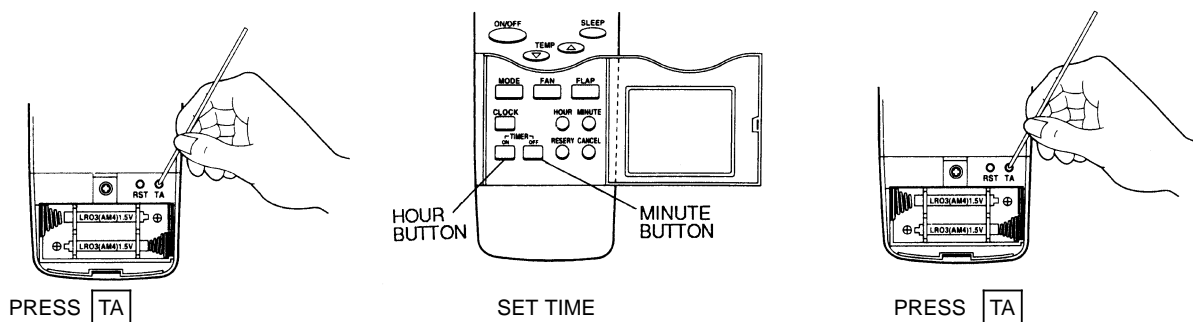

Fig. 23 — Setting The Current Time

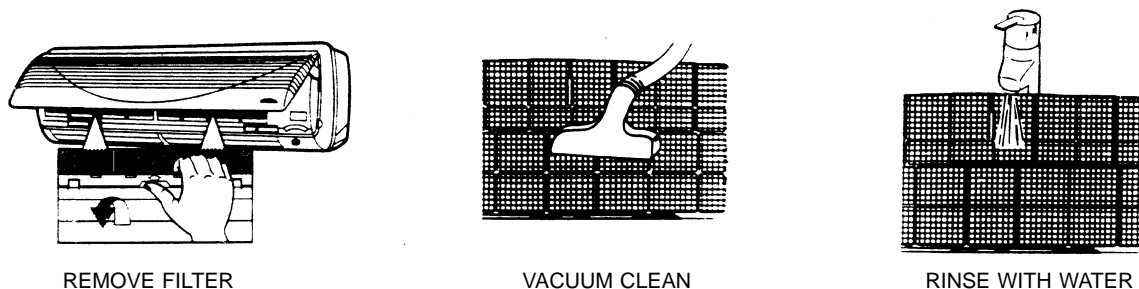

Fig. 24 — Air Filter Maintenance

SERVICE

⚠ WARNING

When servicing unit, turn off all electric power to unit to avoid shock hazard or injury from rotating parts.

⚠ CAUTION

Do not vent refrigerant to atmosphere when servicing unit. Recover refrigerant during system repair or unit removal.

Diagnostic Codes — This unit is equipped with a microprocessor control which continuously monitors the operation of the unit. If an operational fault is detected, a fault is indicated by the flashing of the green “UNIT ON” light on the front of the fan coil unit. A red LED (light-emitting diode) indicator light, located on the control board in the control box of the indoor unit, will emit a flash code which can be used to troubleshoot a system problem. The control will continue to monitor the unit and, if the conditions which cause the fault are cleared, the unit will return to normal operation. If the fault code is present for 5 cycles of the unit, the unit will be locked out and the alarm is indicated by the flashing of the green “UNIT ON” light on the front of the fan coil unit.

To access the LED indicator light, remove the front cover of the unit by removing the 3 screws holding it in place.

If the LED indicator light continuously flashes on for one second, then off for one second, the control is functioning properly and no fault is present. A fast flashing LED indicates that a fault has been detected. Table 9 lists the number of quick flashes and the associated fault. If the system does not operate, and the LED indicator does not flash, either the power to the control board is off, or the control board has failed.

System Tests — System tests listed below are performed continuously by the microprocessor. If a fault is indicated, then the system allows only limited operation until the problem is resolved. If the problem resolves itself, then the code is cleared and operation resumes.

THERMISTOR TESTS — Each thermistor is tested for high limit out of range (shorted condition) and low limit out of range (open condition). If the thermistor is out of range, the fault status indicator comes on and the LED flashes the appropriate fault code.

THERMISTORS — Proper thermistor location and correct temperature sensing are critical to unit operation. Good thermal contact is also required. Thermistor cable assemblies are provided with fan coil units to run between indoor and outdoor units. High-voltage and thermistor cable assemblies should not touch each other, and cable runs may be extended up to 200 feet. With unit running, the thermistor integrity may be checked by measuring the d.c. voltage across the two thermistor connections. Approximate temperature is indicated in Table 10.

Table 9 — System Fault Codes

NO. OF QUICK LED FLASHES	SYSTEM FAULT
2	Room Air Thermistor
3	Indoor Coil Thermistor
4	Outdoor Coil Thermistor*
5	Compressor Malfunction
6	Reversing Valve Malfunction*
7	Outdoor Air Thermistor*
8	Indoor Fan Failure
9	Discharge Air Thermistor

LED — Light-Emitting Diode

*Heat pump systems only.

NOTE: If the LED light continuously flashes on for one second, then off for one second, the control is functioning properly and no fault is present.

COMPRESSOR FAILURE

If the System is in Cooling or Dehumidification Mode — After 5 minutes of operation, if the temperature of the indoor coil is not 4° F less than at the time the call for cooling started, then a compressor failure is indicated on the remote controller LCD display.

If the System is in Heat Pump Heating Mode (38BK only) — After 5 minutes of operation, if the temperature indicated by the outdoor coil thermistor is not 4° F less than at the time the call for heating started, then a compressor failure is indicated.

REVERSING VALVE FAILURE (38BK Only)

If the System is in Cooling or Dehumidification Mode — After 5 minutes of operation, if the temperature at the indoor coil is 4° F more than at the time the call for cooling started, then a reversing valve failure is indicated.

If the System is in Heat Pump Heating Mode — After 5 minutes of operation, if the temperature indicated by the outdoor coil is 4° F more than at the time the call for heating started, then a reversing valve failure is indicated.

System Safeties and Interlocks

INDOOR FAN FAILURE — If the indoor fan rpm shows greater than 800 rpm for 30 seconds with the fan in the off mode, then this test indicates an indoor fan failure. Also, if the indoor fan rpm is greater than 1700 rpm for 30 seconds, then this test indicates an indoor fan failure.

COMPRESSOR SHORT-CYCLING PROTECTION — There is a time delay of 3 minutes between compressor turning off and turning back on.

INDOOR COIL FREEZE PROTECTION (Cooling or Dehumidification Mode Only) — If the indoor coil temperature is less than or equal to 32 F for 10 minutes after the compressor has started, then the compressor and outdoor fan are turned off. The indoor fan continues to run at the user-selected speed until the indoor coil reaches 44 F. At that time, the compressor and outdoor fan will restart.

INDOOR COIL HIGH-TEMPERATURE PROTECTION (Heat Pump Systems Only) — If indoor coil temperature is greater than or equal to 135 F, the outdoor fan shuts down. The outdoor fan will restart automatically when the indoor coil temperature drops to 120 F.

TROUBLESHOOTING

See Table 11 and Fig. 25-28 to assist in troubleshooting the 40QN fan coil units.

Table 10 — 40QN Thermistor Properties*

TEMP (F)	MINIMUM OHMS	NOMINAL OHMS	MAXIMUM OHMS	MINIMUM THERMISTOR VOLTS — DC	NOMINAL THERMISTOR VOLTS — DC	MAXIMUM THERMISTOR VOLTS — DC
-40	303,300	342,700	386,200	4.80	4.82	4.84
-30	211,500	237,276	265,444	4.72	4.75	4.77
-20	149,721	166,689	185,146	4.61	4.65	4.68
-10	107,379	118,776	130,973	4.48	4.52	4.55
0	77,281	85,677	93,867	4.30	4.35	4.40
10	56,567	62,617	68,205	4.09	4.16	4.21
20	42,661	46,302	50,129	3.86	3.92	3.98
30	32,043	34,580	37,220	3.59	3.66	3.72
32	30,300	32,550	35,120	3.53	3.60	3.66
40	24,061	26,118	27,960	3.28	3.36	3.43
50	18,650	19,900	21,180	2.99	3.05	3.11
60	14,402	15,312	16,219	2.67	2.73	2.79
70	11,247	11,883	12,518	2.36	2.42	2.47
80	8,820	9,299	9,779	2.06	2.11	2.16
90	6,846	7,339	7,754	1.76	1.83	1.88
100	5,487	5,829	6,187	1.52	1.57	1.63
110	4,367	4,667	4,976	1.29	1.34	1.40
120	3,502	3,760	4,026	1.09	1.14	1.19
130	2,830	3,051	3,281	0.92	0.97	1.02
140	2,300	2,489	2,687	0.77	0.82	0.87
150	1,880	2,045	2,216	0.65	0.69	0.74
160	1,547	1,688	1,836	0.55	0.59	0.63
170	1,280	1,402	1,531	0.46	0.50	0.53
180	1,065	1,170	1,282	0.39	0.42	0.45
190	890	982	1,078	0.33	0.36	0.39
200	748	828	913	0.28	0.31	0.33
210	631	701	766	0.24	0.26	0.28
212	611	678	751	0.23	0.25	0.28

*Circuit volts = 5 vdc.

Table 11 — Troubleshooting

PROBLEM	POTENTIAL SOURCE	ACTION
Unit does not operate	Circuit breaker has tripped or fuse is blown	Reset the circuit breaker or replace the fuse.
	Power failure	Restart fan coil unit operation when power is restored.
	Voltage is too low	Confirm the available voltage.
Insufficient Cooling	Air filter is blocked with dust	Clean the air filter.
	Temperature is not set properly	Check and reset if necessary.
	Window(s) and/or door(s) are open	Close window(s) and door(s).
	Outdoor unit is obstructed	Remove the obstruction.
	Fan speed is too low	Change the fan speed
	Operation mode is set to fan or auto. mode	Change to cooling operation or reset temperature (using remote controller).
Insufficient Heating*	Air filter is blocked with dust	Clean the air filter.
	Temperature is not set properly	Check and reset if necessary.
	Window(s) and/or door(s) are open	Close window(s) and door(s).
	Outdoor unit is obstructed	Remove the obstruction.
Unit stops during operation	Off timer is operating	Turn off the off timer function.
	Room temperature has reached the programmed set point	Normal unit operation.

*Heat pump systems only.

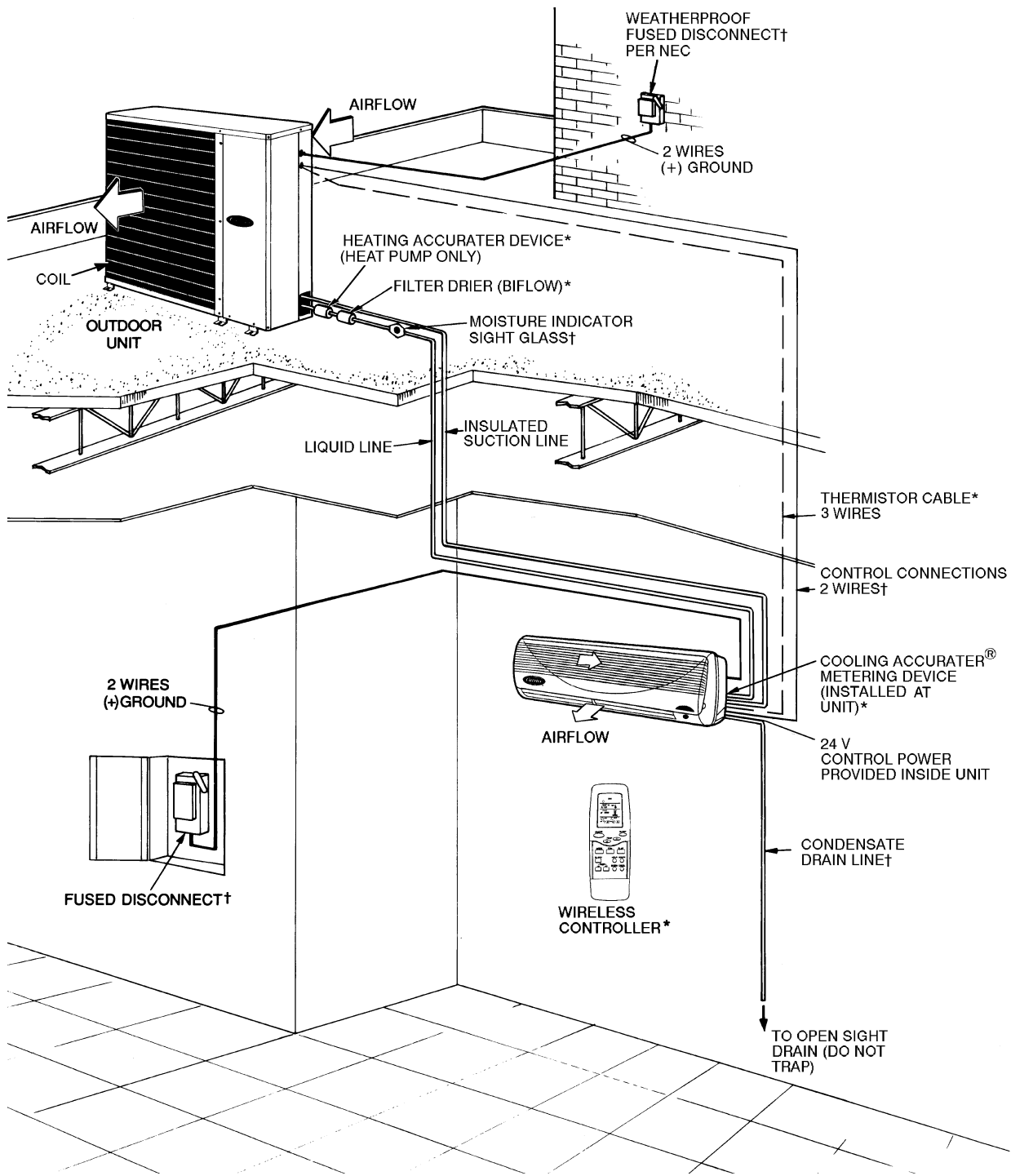

LEGEND









- NEC** — National Electrical Code
- ==== Piping
- Line Voltage
- 24 V
- - - - Thermistor
- *Standard.
- †Field supplied.

NOTES:

1. All piping must follow standard refrigerant piping techniques. Refer to Carrier System Design Manual.
2. All wiring must comply with the applicable local and national codes.
3. Liquid line need not be insulated.
4. Wiring and piping shown are general points-of-connection guides only and are not intended for a specific installation.
5. Insulate condensate drain if installed in a conditioned space.

Fig. 25 — Typical Piping and Wiring — High Wall Systems, 18,000 and 24,000 Btuh

LEGEND AND NOTES FOR FIG. 26-28

AGING	— For the Burn-In Test (short these terminals)	OFR	— Outdoor-Fan Relay
AS, ASS'Y	— Assembly	OL	— Overload
C	— Contactor	PCB	— Printed Circuit Board
CAP	— Capacitor	PTC	— Start Thermistor
CH	— Crankcase Heater	RA Th	— Return Air Thermistor
CLO	— Compressor Lockout	RC	— Resistor Capacitor
CN	— Connector	RCV	— Receiver
COMP	— Compressor	RVS	— Reversing Valve Solenoid
CT	— Current Transformer	SC	— Start Capacitor
EMI	— Electromagnetic Interference	SR	— Start Relay
FL	— Fuse Link	ST	— Start Thermistor
FMC	— Fan Motor Capacitor	STM	— Step Motor
FU	— Fuse	TB	— Terminal Block
GND	— Ground	TG	— Time Guard
HA	— Home Automation	TP	— Thermal Protector
HPS	— High-Pressure Switch	TRAN	— Transformer
HS	— Hall (Rpm) Sensor		Terminal (Marked)
HTR	— Heater		Terminal (Unmarked)
IDC Th	— Indoor-Coil Temperature Thermistor		Splice
IFM	— Indoor-Fan Motor		Terminal Block
JEM-A	— Japan Electric Manufacturing Industry Association		Factory Wiring
K	— Relay		Field Control Wiring
LLPS	— Liquid Low Pressure Switch		Field Power Wiring
LPS	— Low-Pressure Switch		Accessory or Optional Wiring
LS	— Limit Switch		
ODA Th	— Outdoor-Air Thermistor		
ODC Th	— Outdoor-Coil Thermistor		
OFM	— Outdoor-Fan Motor		

1. If any of the original wire furnished must be replaced, it must be replaced with type 90 C wire or its equivalent.
2. Wire in accordance with National Electrical Code (NEC) and local codes.
3. The CLO locks out the compressor to prevent short cycling on compressor overloads and safety devices. Before replacing CLO, check these devices. A minimum one amp turn required to hold contacts closed.
4. Thermistor wiring cable 35 feet long provided with unit.
5. IFM, OFM and compressor have internal thermal protectors.
6. Transformer has a 2 amp thermal fuse on the primary side.

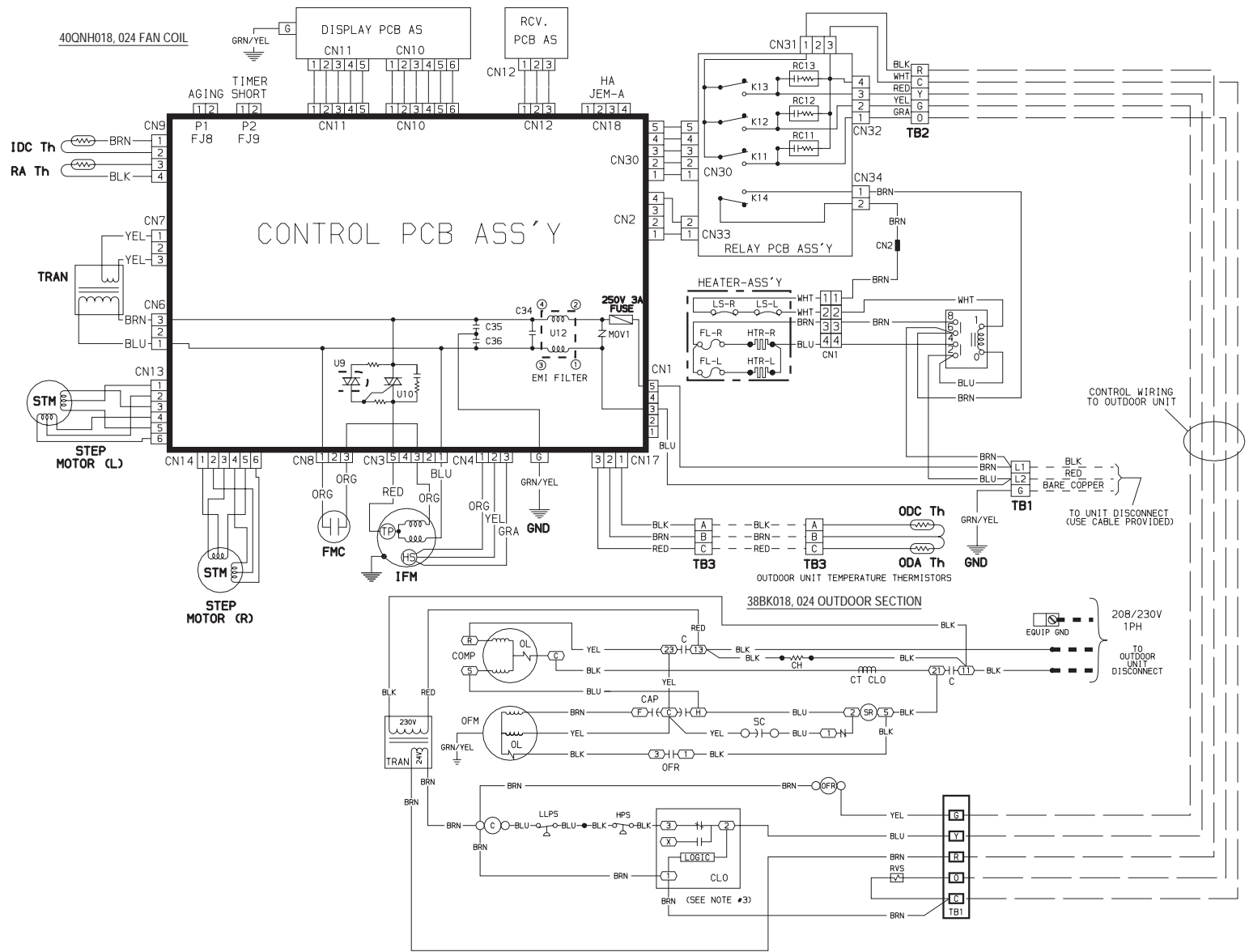

RELAY CHART	
COMPRESSOR	K13
REV. VALVE	K11
OUTDOOR FAN	K12

THERMISTOR EQUIVALENCE		
TEMPERATURE		RESISTANCE
°F	°C	Ω
95	35	6,500
72	22	11,400
32	0	32,500
ALL THERMISTORS ARE IDENTICAL		

Fig. 26 — 40QNH Fan Coil Unit with 38BK Outdoor Heat Pump Unit

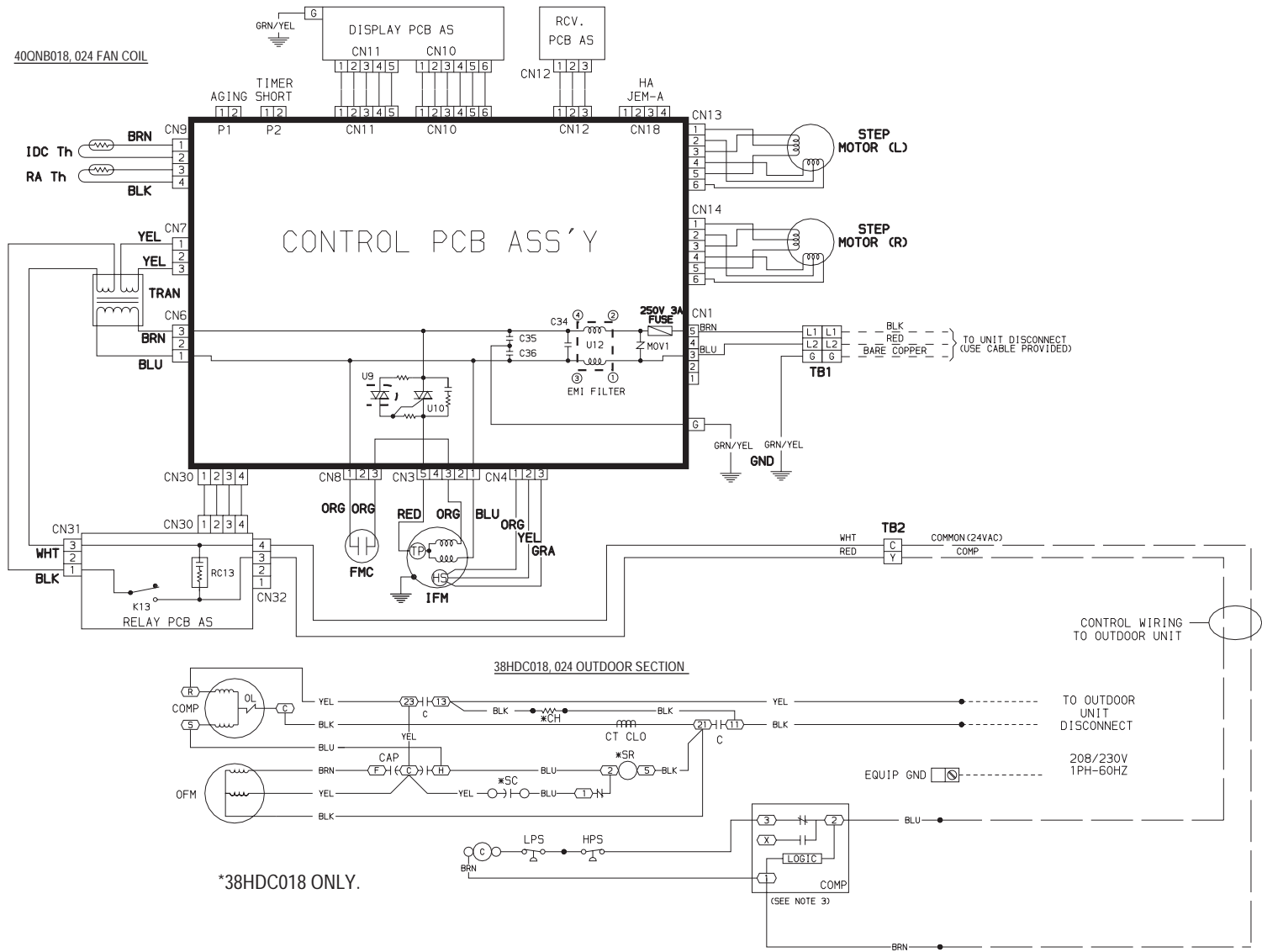
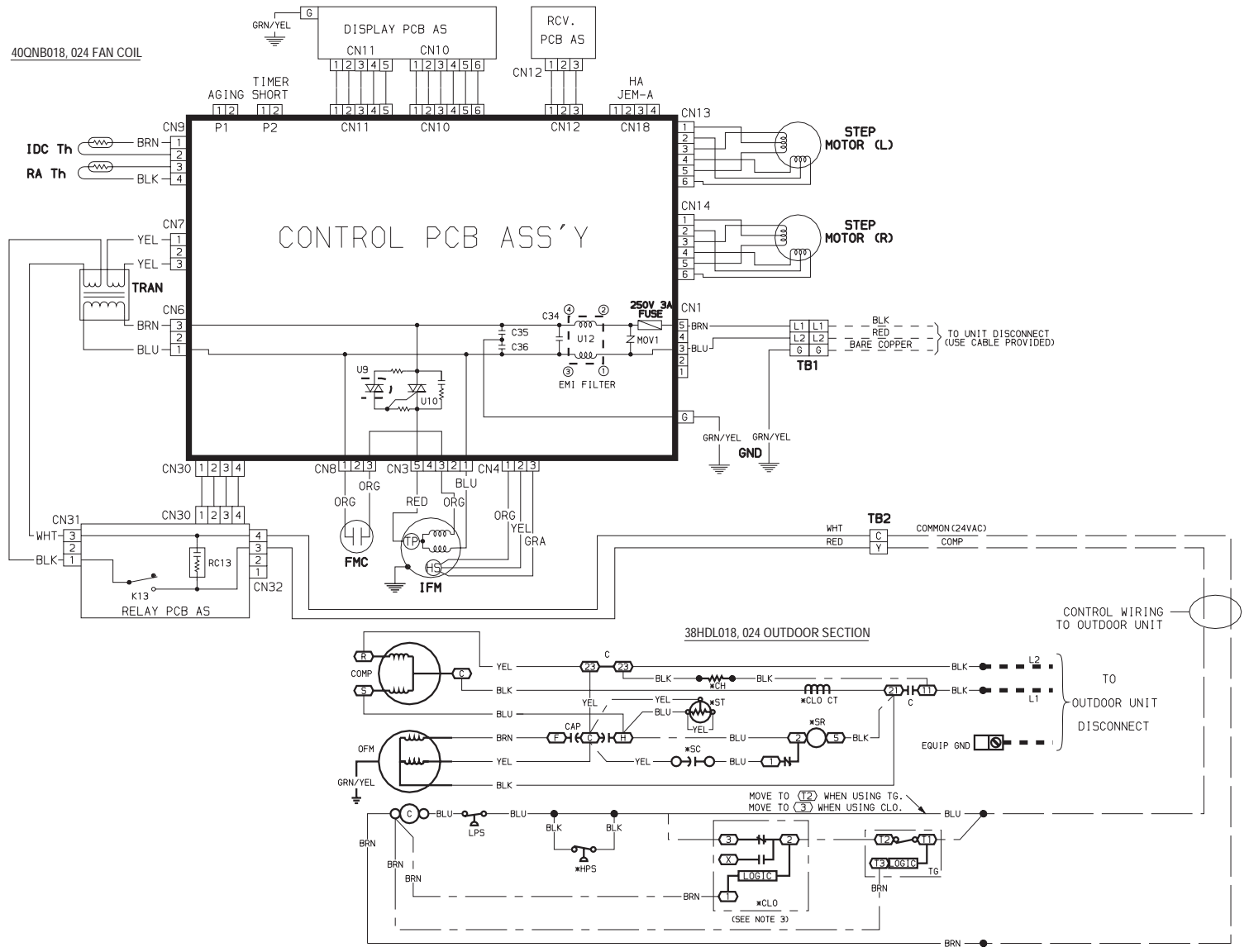
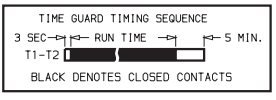

Fig. 27 — 40QNB Fan Coil Unit with 38HDC Cooling Only Outdoor Condensing Unit

Manufacturer reserves the right to discontinue, or change at any time, specifications or designs without notice and without incurring obligations.



RELAY CHART	
COMPRESSOR	K13



THERMISTOR EQUIVALENCE		
TEMPERATURE		RESISTANCE
*F	*C	Ω
95	35	6,500
72	22	11,400
32	0	32,500
ALL THERMISTORS ARE IDENTICAL		

Fig. 28 — 40QNB Fan Coil Unit with 38HDL Cooling Only Outdoor Condensing Unit

START-UP CHECKLIST

I. PRELIMINARY INFORMATION

OUTDOOR UNIT: MODEL NO. _____ SERIAL NO. _____

INDOOR UNIT: MODEL NO. _____ SERIAL NO. _____

ACCESSORIES: _____

PISTONS (38HDC, HDL and 38BK SYSTEMS ONLY): INDOOR SIZE: _____

OUTDOOR SIZE (38BK SYSTEMS ONLY): _____

REFRIGERANT PIPING: EQUIVALENT LINE LENGTH: _____ (IF OVER 50 FT)*

LIFT: FAN COIL ABOVE OUTDOOR UNIT (IF OVER 25 FT)*? _____

FAN COIL BELOW OUTDOOR UNIT (IF OVER 25 FT)*? _____

*APPLIES ONLY TO 38HDC, HDL AND 38BK UNITS USING LONG-LINES APPLICATIONS. MAXIMUM EQUIVALENT LINE LENGTH FOR 38HDS SYSTEMS IS 50 FT. MAXIMUM LIFT ON 38HDS APPLICATIONS IS 30 FT FROM LOWEST SYSTEM POINT TO HIGHEST SYSTEM POINT.

II. PRE-START-UP

INDOOR UNIT (REFER TO OUTDOOR UNIT INSTALLATION INSTRUCTIONS FOR OUTDOOR UNIT PRE-START-UP FUNCTIONS)

IS THERE ANY SHIPPING DAMAGE? _____

IF YES, WHERE? _____

WILL THIS DAMAGE PREVENT UNIT START-UP? _____

CHECK POWER SUPPLY. IS IT 208/230, SINGLE PHASE? _____

HAS GROUND WIRE BEEN CONNECTED? _____

HAS THE CORRECT SIZE FUSE OR HACR BREAKER BEEN PROVIDED? _____

ARE POWER WIRES TO THE UNIT SIZED AND INSTALLED PROPERLY? _____

IS THE DISCONNECT SWITCH INSTALLED IN SIGHT FROM THE UNIT? _____

IS THE LOW-VOLTAGE CABLE (INDOOR TO OUTDOOR UNIT) RUN AND CONNECTED PROPERLY?

HAS CONDENSATE DRAIN BEEN RUN AND SLOPED PROPERLY? _____

IS AIR FILTER(S) IN PLACE? _____

IS UNIT MOUNTED LEVEL? _____

IS COOLING PISTON INSTALLED, THE CORRECT SIZE, AND IN THE CORRECT DIRECTION (38HDC, HDL AND 38BK SYSTEMS ONLY)? _____

IS HEATING PISTON INSTALLED, THE CORRECT SIZE, AND IN THE CORRECT DIRECTION (38BK SYSTEMS ONLY)? _____

III. PIPING

IS A LIQUID LINE SOLENOID INSTALLED IF REQUIRED BY LONG-LINE APPLICATIONS (38HDC, HDL AND 38BK SYSTEMS ONLY)? _____

IS FILTER DRIER INSTALLED AT THE OUTDOOR UNIT (38HDC, HDL AND 38BK SYSTEMS ONLY)? _____

HAVE LEAK CHECKS BEEN MADE AT THE COMPRESSOR, OUTDOOR UNIT, FLARE CONNECTIONS, FILTER DRIERS, AND FUSIBLE PLUGS WITH A LEAK DETECTOR?† _____

†FIELD PIPING AND ALL TUBING CONNECTIONS MUST BE LEAK TESTED BY THE PRESSURE METHOD DESCRIBED IN CARRIER GENERAL TRAINING FOR AIR CONDITIONING MANUAL (GTAC2), MODULE 5. USE R-22 AT APPROXIMATELY 25 PSIG BACKED UP WITH AN INERT GAS TO REACH A TOTAL SYSTEM PRESSURE NOT TO EXCEED 245 PSIG.

START-UP CHECKLIST (cont)

HAS PIPING SYSTEM BEEN EVACUATED TO 1000 MICRONS? _____

HAS SYSTEM CHARGE BEEN WEIGHED IN (IF REQUIRED)? _____

HAVE SERVICE VALVES BEEN FULLY BACKSEATED? _____

CHECK VOLTAGE: IS VOLTAGE WITHIN RANGE SHOWN FOR UNIT (WITH UNIT OPERATING)?
OUTDOOR _____ INDOOR _____

IV. START-UP

IF UNIT HAS A CRANKCASE HEATER, HAS IT BEEN ON FOR 24 HOURS? _____

MEASURE AND RECORD THE:

AIR ENTERING OUTDOOR UNIT: _____ F

AIR ENTERING INDOOR UNIT: _____ F

DISCHARGE LINE TEMPERATURE: _____ F

VAPOR LINE TEMPERATURE: _____ F

MEASURE AND RECORD THE:

VAPOR LINE PRESSURE: _____ PSIG

DISCHARGE PRESSURE: _____ PSIG

CUT ALONG DOTTED LINE

CUT ALONG DOTTED LINE