

53DS-900---060 (R-22)
53DS-900---086 (Puron)

Duct-Free Systems
Cooling Only and Heat Pump Units
Low Ambient Temperature Controller Accessory

Installation Instructions

NOTE: Read and become familiar with these instructions before beginning installation.

SAFETY CONSIDERATIONS

Installing and servicing air-conditioning equipment can be hazardous due to system pressures and electrical components. Only trained and qualified personnel should install or service air-conditioning equipment. When working on air-conditioning equipment, observe the precautions provided in literature, tags, and labels attached to the unit.

Follow all safety codes. Wear safety glasses, protective clothing, and work gloves. Use quenching cloth for brazing operations. Have fire extinguisher available. Read these instructions thoroughly and follow all warnings or cautions included in literature and attached to the unit. Consult local building codes and National Electrical Code (NEC) for special requirements.

Recognize safety information. This is the safety-alert symbol . When you see this symbol on the unit and in instructions or manuals, be alert to the potential for personal injury.

Understand these signal words: DANGER, WARNING, and CAUTION. These words are used with the safety-alert symbol. DANGER identifies the most serious hazards which **will** result in severe personal injury or death. WARNING signifies hazards which **could** result in personal injury or death. CAUTION is used to identify unsafe practices which **may** result in minor personal injury or product and property damage. NOTE is used to highlight suggestions which **will** result in enhanced installation, reliability, or operation.

 WARNING

ELECTRICAL SHOCK HAZARD

Failure to follow this warning could result in personal injury or death.

Before beginning any modification or installation of this kit, be sure the main electrical disconnect is in the OFF position. Ensure power is disconnected to the fan coil unit. On some systems both the fan coil and the outdoor unit may be on the same disconnect. Tag the disconnect switch with a suitable warning label. There may be more than one disconnect.

GENERAL

IMPORTANT: Heat pump models require an isolation relay to prevent fan cycling in heat pump mode. See Table 1 for isolation relay part numbers.

Table 1—Isolation Relay Part Numbers

R-22	Part No.	RCD Part No.	Voltage
38BNQ009/012	HN61KK912	P283-0294	120v
38BCQ018/024	HN61KK912	P283-0294	120v
38BNQ018/036	HN61KK913	P283-0295	240v
R-410a	Part No.	RCD Part No.	Voltage
38QRR/QRF	HN61KK066	P283-0293	24v
538B_R/538Q_R	HN61KK066	P283-0293	24v

Wind baffles are required for all R410a units (18-60k are blow through design) used for low ambient operation. Use factory accessory listed in Table 2.

Wind baffles are not available from the factory for R-22 condensers (draw through design). If wind baffles are required, they need to be field fabricated. Baffles should be located 6" from unit on coil side of condenser (2 sides). Use CAUTION, do not drill into coil

Table 2—Wind Baffle Accessories for R-410A Units

R-410a Models	Wind Baffle Part No.
38HDF/QRF/HDR/RRR018 538E_F/538Q_F018	53DS-900---070
38HDF/HDR024, 38HDF030, 38QRF/RRR024 538E_F/538A_R024 538E_F030, 538Q_F/538B_R024	53DS-900---087
38HDF036, 38QRF030/035/036, 38HDR/RRR030/036 538E_F036 538Q_F030/035/036, 538A_R/538B_R030/036	53DS-900---071
38HDR/RRR048, 060 538A_R/538B_R048, 060	53DS-900---088

Winter Start Control (part number KAAWS0101AAA) is required when low ambient operation (cooling below 55°F) is required for cooling and heat pump models (018-060) that have a low pressure switch.

The Winter Start Control kit uses a time-delay relay to bypass the low-pressure switch for three (3) minutes on start-up. the time delay relay will take the low pressure switch out of the control circuit to allow the system to build pressure eliminating nuisance trips. *Units with low pressure switches: 38HDR/HDF/RRR/QRF and 538A_B/E_F, 538Q_F.*

Crankcase Heater is required for low ambient operation.

NOTE: Some condensers have a Crankcase Heater as standard. Check unit Installation and Service Instructions.

These instructions cover the installation of low ambient temperature controller accessory kit on the duct-free cooling and heat pump condensing units.

The low ambient temperature head pressure controller (HPC) is a fan control device activated by a high cycle rate pressure switch. It is specifically designed for use with duct-free systems, cooling only and heat pump units.

The low ambient temperature controller is designed to maintain a condensing pressure of 200 to 225 psig for BNC/BNQ models and 321 to 362 psig for HDF/HDR and QRF/QRR models by cycling the outdoor-fan motor. No field adjustments or calibrations are required.

All of the components necessary for installing the low ambient temperature controller are included in the package. This kit consists of a pressure switch and installation instructions. When unpacking the accessory, carefully inspect for shipping damage. If damage is evident, return for replacement.

INSTALLATION

STEP 1 —Mount Pressure Switch

1. Place 3 drops of compressor oil in the pressure switch for lubrication. Use oil appropriate for R-22 or R-410a depending on system.
2. Mount the pressure switch as shown in Fig. 1-2.
3. Coil up the excess wire and secure next to the pressure switch.

STEP 2 —Connect Power Wiring

All wiring must comply with local codes and National Electrical Code (NEC) requirements. See Fig. 3-5 for accessory wiring.

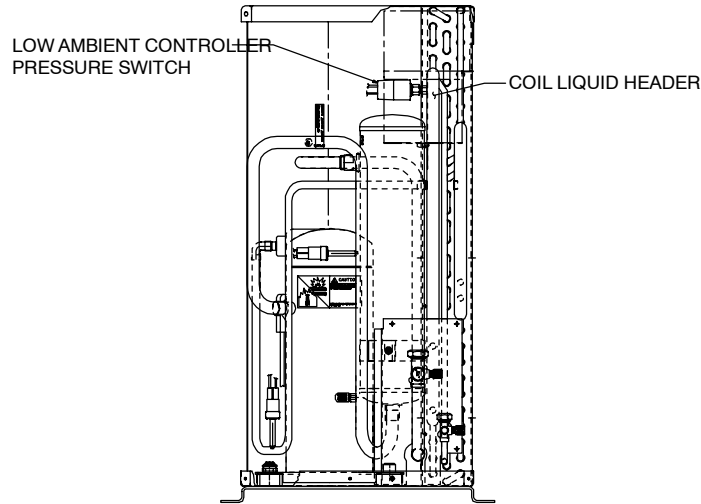

D06005

**Fig. 1 – Low Ambient Control for
38HDF, HDR / 38QRF, QRR, 538A, 538E / 538B, 538Q**

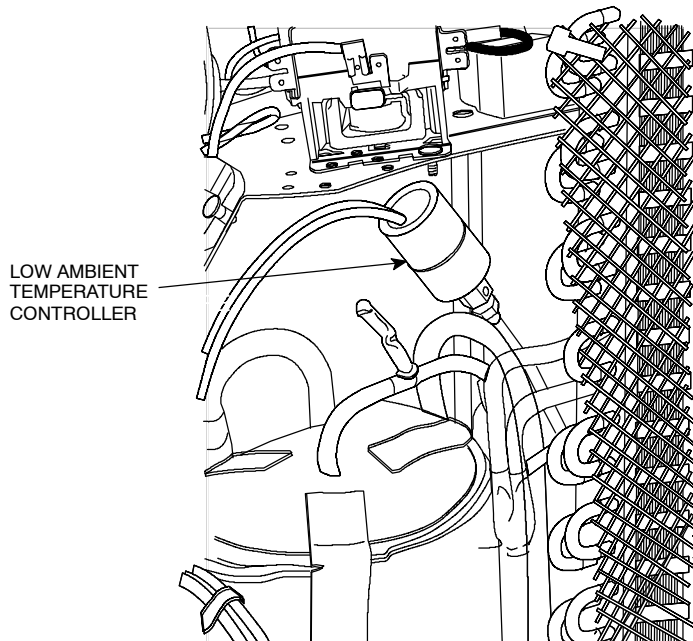

D06001

**Fig. 2 – Low Ambient Temperature Control Location
38BNC/BNQ009-036**

COOLING ONLY MODELS	
Model No.	Wire Color
38BNC009-036	White
38HDF018-036	Black
38HDR018-060	Black
538A Series	Black
538E Series	Black

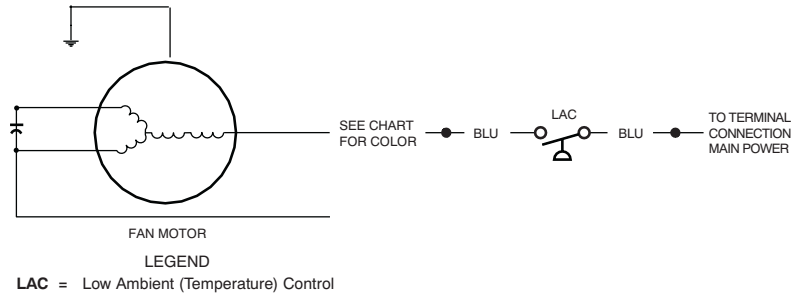

**Fig. 3 – Low Ambient Temperature Control Wiring
Cooling Only Models**

D06002

HEAT PUMP MODELS (Reversing Valve Energized in Cooling)	
Model No.	Wire Color
38QRF018-036	Black
38QRR018-060	Black
538BNR018-060	Black
538QNF018-036	Black

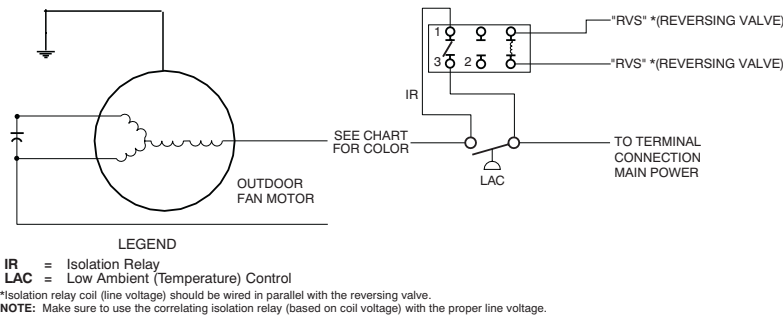

**Fig. 4 – Low Ambient Temperature Control Wiring
Heat Pump Models
(Reversing Valve Energized in Cooling)**

D06004

HEAT PUMP MODELS (Reversing Valve Energized in Heating)	
Model No.	Wire Color
38BNQ9-12 (115v)	Black
38BNQ18-36 (208v)	Black

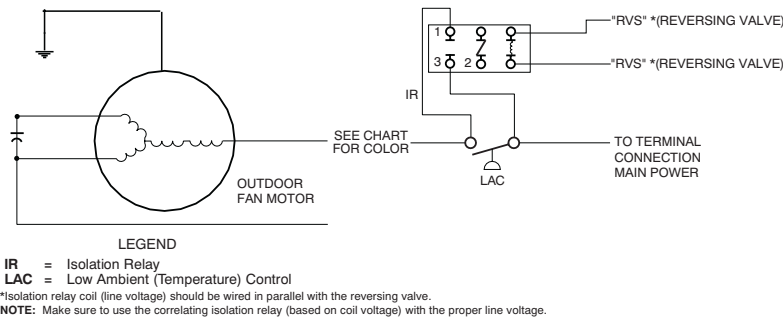

**Fig. 5 – Low Ambient Temperature Control Wiring
Heat Pump Models
(Reversing Valve Energized in Heating)**

D06003

53DS--900-- --060,086

CHECK OPERATION

Before starting the system to check operation of low ambient temperature controller, ensure that the power wiring and location of controller assembly are correct. To check operation of low ambient temperature controller:

1. Turn power on to system.
2. Set thermostat below room temperature.
3. Ensure that there is the standard 3-minute time delay for the microprocessor controlled high wall fan coil systems.
4. Check time delay of installed accessories:
Under-ceiling (40QAC/QAQ) fan coils using the duct-free 24-v thermostat delay settings: 2 or 4 minute delay.

The outdoor-fan motor will not operate until the condensing pressure reaches the control set point of 225 psig for 38BNC/BNQ models or 362 psig for 38QRF-018-036 and 38QRR-018-060 models (± 10 psig). When the set point is reached, the outdoor fan will cycle to maintain the set point condensing pressure.

If the low ambient temperature controller does not operate correctly:

- Ensure that power is being supplied to the system.
- Check condensing pressure: if condensing pressure is below 200 psig for 38BNC/BNQ models or 321 psig for 38QRF-018-036 and 38QRR-018-060 models, the outdoor-fan motor should be off and there should be no voltage across the 2 blue fan power leads coming out of the controller. If condensing pressure is about 225 psig or greater for 38BNC/BNQ models or 362 psig for 38QRF-018-036 and 38QRR-018-060 models, the outdoor-fan motor should be on and will cycle off at around 200 psig for 38BNC/BNQ or 321 psig for 38QRF-018-036 and 38QRR-018-060 models.