



© 2003 Lennox Industries Inc.
Dallas, Texas, USA



CB28UH
Upflow Position
(With Optional Electric Heat)

INSTALLATION INSTRUCTIONS

Merit® CB28UH

UPFLOW HORIZONTAL BLOWER COIL UNITS
504,739M
05/03

TP Technical
Publications

Litho U.S.A.

Table of Contents

CB28UH Series Units	1
General	1
Shipping & Packing List	1
Unit Dimensions	2
Requirements	4
Installation	4
Field Piping Connections	6
Condensate Drain	6
Filters	7
Sealing the Unit	7
Blower Speed Adjustments	7
Electrical	10
System Wiring Diagrams	11

**RETAIN THESE INSTRUCTIONS
FOR FUTURE REFERENCE**

⚠ IMPORTANT

The Clean Air Act of 1990 bans the intentional venting of refrigerant (CFC's and HCFC's) as of July 1, 1992. Approved methods of recovery, recycling or reclaiming must be followed. Fines and/or incarceration may be levied for non-compliance.

⚠ WARNING

Product contains fiberglass wool.

Disturbing the insulation in this product during installation, maintenance, or repair will expose you to fiberglass wool. Breathing this may cause lung cancer. (Fiberglass wool is known to the State of California to cause cancer.)

Fiberglass wool may also cause respiratory, skin, and eye irritation. To reduce exposure to this substance or for further information, consult material safety data sheets available from address shown below, or contact your supervisor.

Lennox Industries Inc.
P.O. Box 799900
Dallas, TX 75379-9900

CB28UH Series Units

The Lennox Merit® CB28UH series blower coil units are designed for installation with optional field-installed electric heat and a matched remote outdoor unit. These units are for indoor installation only.

The CB28UH units are designed for upflow/horizontal positional installations and are shipped (completely assembled) from the factory for upflow and horizontal right-hand discharge.

General

These instructions are intended as a general guide and do not supersede local codes in any way. Consult authorities having jurisdiction before installation.

Check equipment for shipping damage. If you find any damage, immediately contact the last carrier.

Shipping and Packing List

CB28UH Series
Package 1 of 1 contains

1 - Assembled blower coil unit



Upflow Unit Dimensions - inches (mm)

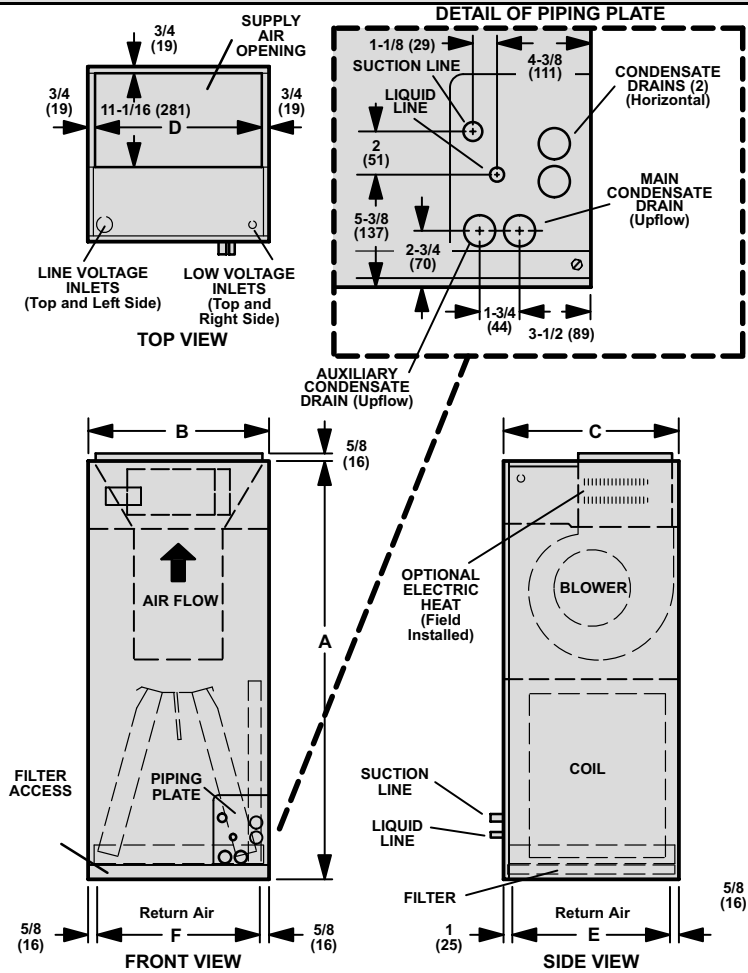

CB28UH UPFLOW POSITION

AUXILIARY DRAIN ON LEFT
MAIN DRAIN ON RIGHT

Model No.	CB28UH-018/024 CB28UH-030		CB28UH-036 CB28UH-042		CB28UH-048 CB28UH-060	
	inch	mm	inch	mm	inch	mm
A	45-1/4	1149	49-1/4	1251	52-1/2	1334
B	16-1/4	413	21-1/4	540	21-1/4	540
C	20-5/8	524	20-5/8	524	22-5/8	575
D	14-3/4	375	19-3/4	502	19-3/4	502
E	19	483	19	483	21	533
F	15	351	20	508	20	508

Torque Table

Part	Recommended Torque	
Blower Motor Bolts	48 in./lbs.	5.42 NM
Blower Set Screw	155 in./lbs.	17.51 NM
Drain Pan Plug	84 in./lbs.	9.49 NM
TXV Chatleff Nuts	20 ft./lbs.	27.11 NM
Sheet Metal	16 in./lbs.	1.80 NM
Machine Screws #10	28 in./lbs.	3.16 NM

Horizontal Left- and Right-Hand Unit Dimensions - inches (mm)

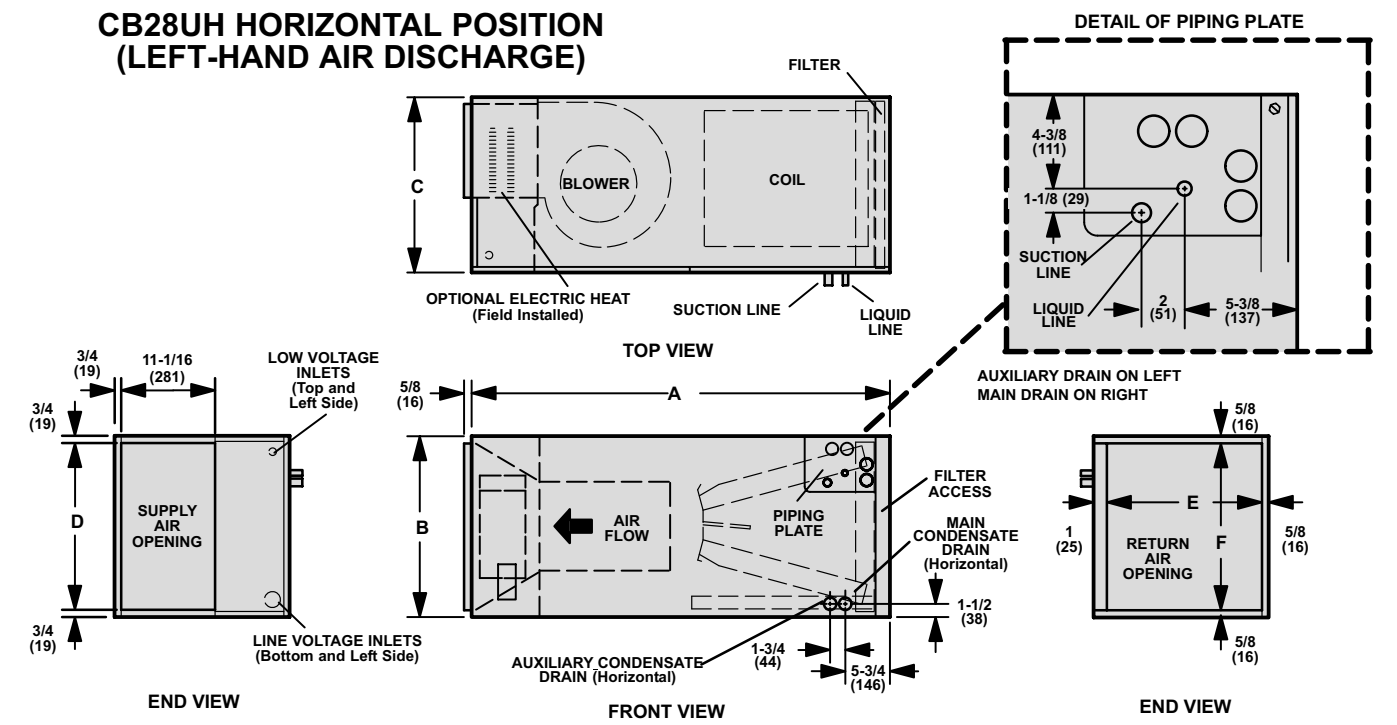
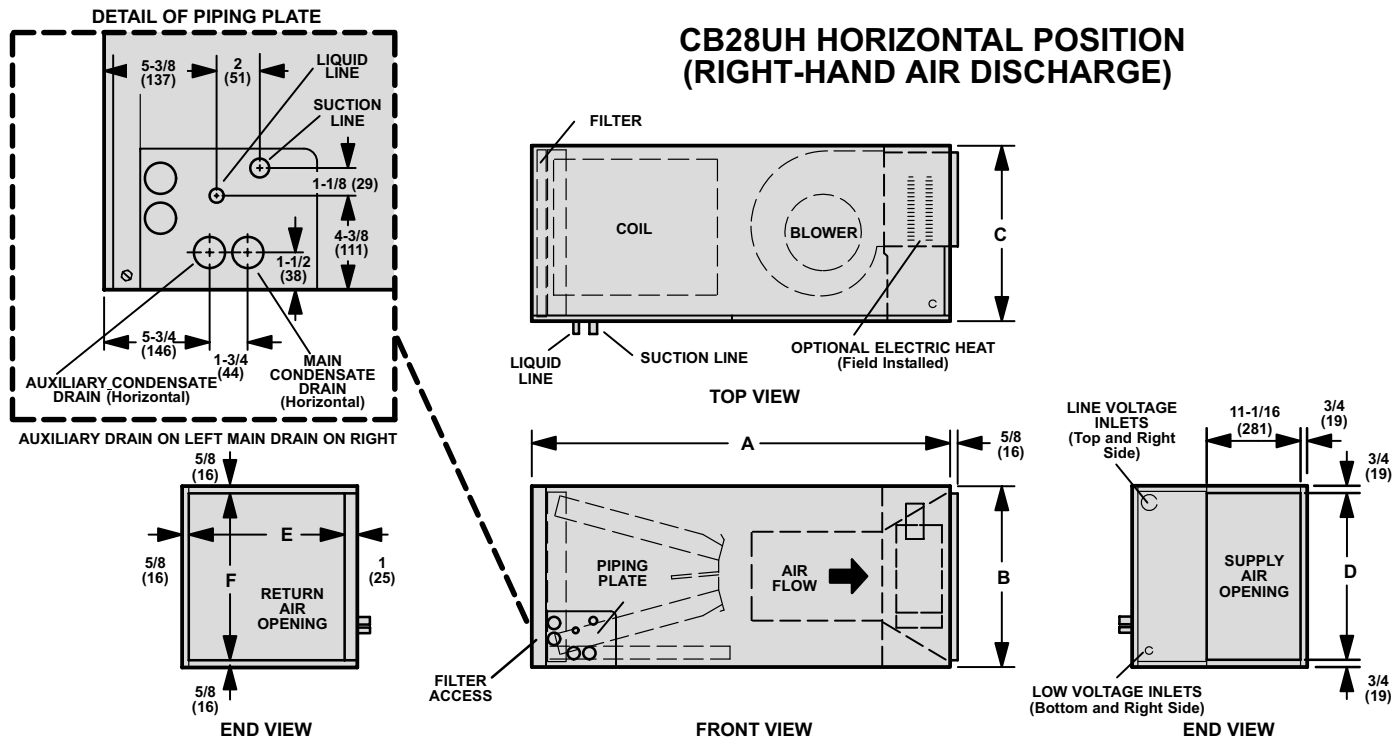

Model No.	A		B		C		D		E		F	
	inch	mm	inch	mm	inch	mm	inch	mm	inch	mm	inch	mm
CB28UH-018/024 CB28UH-030	45-1/4	1149	16-1/4	413	20-5/8	524	14-3/4	375	19	483	15	351
CB28UH-036 CB28UH-042	49-1/4	1251	21-1/4	540	20-5/8	524	19-3/4	502	19	483	20	508
CB28UH-048 CB28UH-060	52-1/2	1334	21-1/4	540	22-5/8	575	19-3/4	502	21	533	20	508

Requirements

Installation of Lennox blower coil units with or without optional electric heat must conform with standards in the National Fire Protection Association (NFPA) "Standard for Installation of Air Conditioning and Ventilation Systems NFPA No. 90A," and "Standard for Installation of Residence Type Warm Air Heating and Air Conditioning Systems NFPA No. 90B," manufacturer's installation instructions and local municipal building codes.

This unit is certified for installation clearances to combustible material as listed on the unit rating plate.

Installation

CB28UH units are factory-configured for upflow or horizontal right-hand discharge installation. For horizontal left-hand discharge, some field modification is required.

⚠ CAUTION

Danger of sharp metallic edges. Can cause injury. Take care when servicing unit to avoid accidental contact with sharp edges.

Upflow Application

- 1 - Remove access panel. Remove corrugated padding from the space between the blower and coil assemblies.
- 2 - To ensure proper operation, remove the horizontal drain pan from units in upflow configurations.
- 3 - Place unit in desired location. Make sure that unit is level. Connect return and supply air plenums as required using sheet metal screws. See figure 1.
- 4 - Mount units that have no return air plenum on a stand at least 14" from the floor for proper air return. Lennox offers an optional upflow unit stand. (45K31 for CB28UH-018, 024, 030; 45K32 for CB28UH-036 through -060.)

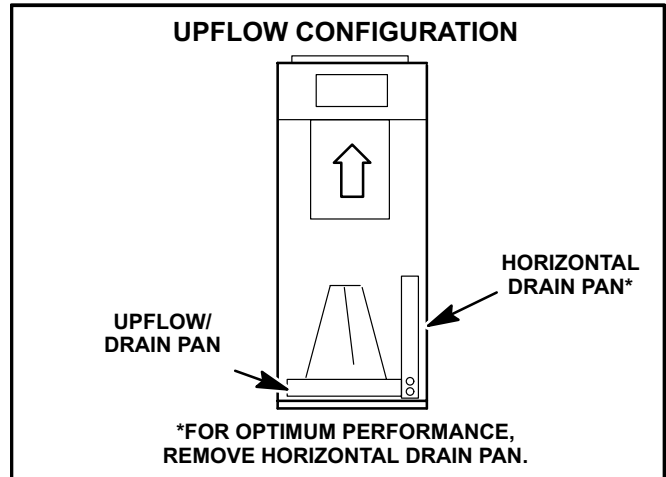

FIGURE 1

Horizontal Right-Hand Discharge Application

- 1 - Remove access panel. Remove corrugated padding from the space between the blower and coil assembly.
 - 2 - No further adjustment is necessary. Set unit so that it is sloped 1/4 inch toward the drain pan end of the unit.
- NOTE - For horizontal applications, an auxiliary drain pan is required. Refer to local codes.*
- NOTE - For horizontal applications in **high humidity areas**, seal around the exiting drain pipe, liquid line and suction line to prevent infiltration of humid air.*

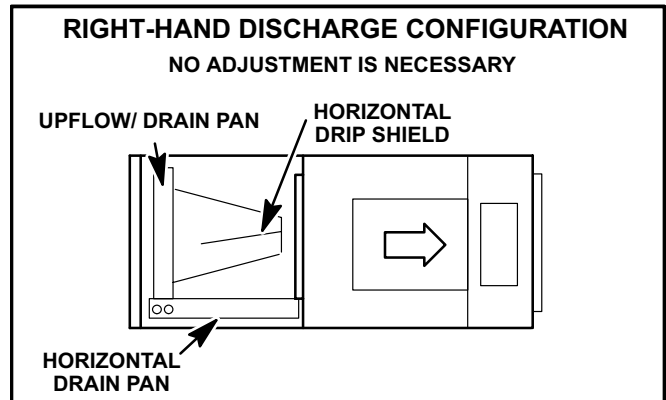

FIGURE 2

3 -If the unit is to be suspended, it must be supported along the entire length of the cabinet. If you use a strap, attach a piece of angle iron or sheet metal to the unit (either above or below) so that the full length of the cabinet is supported. Use securing screws which are no longer than 1/2 inch to avoid damaging the coil or filter. See figure 3. Connect the return and supply air plenums as required using sheet metal screws.

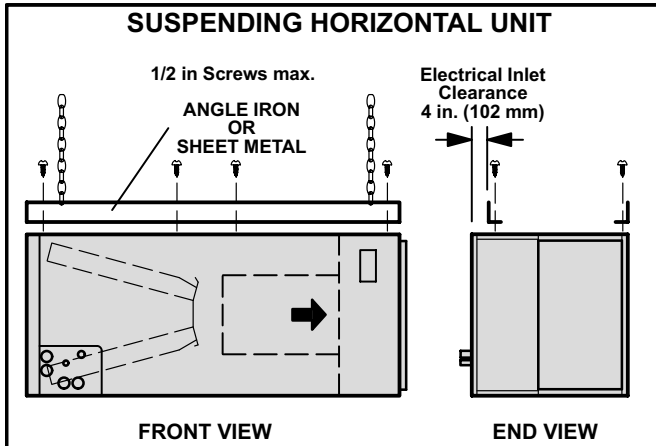

FIGURE 3

⚠ CAUTION

Danger in equipment damage and personal injury. Take care when removing coil assembly from unit installed in right or left-hand applications. Coil may tip into drain pan once clear of cabinet. Support coil when removing.

Horizontal Left-Hand Discharge Application

NOTE - For horizontal applications, an auxiliary drain pan is required. Refer to local codes.

- 1 -Remove access panel. Remove corrugated padding from the space between the blower and coil assembly before operation.
- 2 -Pull coil assembly from unit. Pull off the horizontal drain pan.
- 3 -Remove drain plugs from back drain holes on horizontal drain pan and reinstall them on front holes.
- 4 -Rotate drain pan 180° front to back and install it on the opposite side of coil. Follow the instruction steps with the corresponding numbers in figure 4.
- 5 -Remove screws from top cap. Remove horizontal drip shield screw located in the center of the back coil end seal. See figure 4.
- 6 -Rotate horizontal drip shield 180° front to back.
- 7 -Remove plastic plug from left hole on coil front end seal and reinstall plug in back hole. Re-install horizontal drip shield screw in front coil end seal. Drip shield should drain downward into horizontal drain pan inside coil. See figure 4.

8 -Rotate top cap 180° front to back and align with unused screw holes. Holes must align with front and back coil end plates. Note that top cap has a 45° bend on one side and 90° bend on the other. **The 90° bend must be on the same side as the horizontal drain pan.** See figures 4 and 5.

NOTE - Use extreme care when re-installing screws into coil end plate engaging holes. Misaligned screws may damage coil.

9 -Remove the condensate shield from the right front and install it on the left front as shown in figure 4.

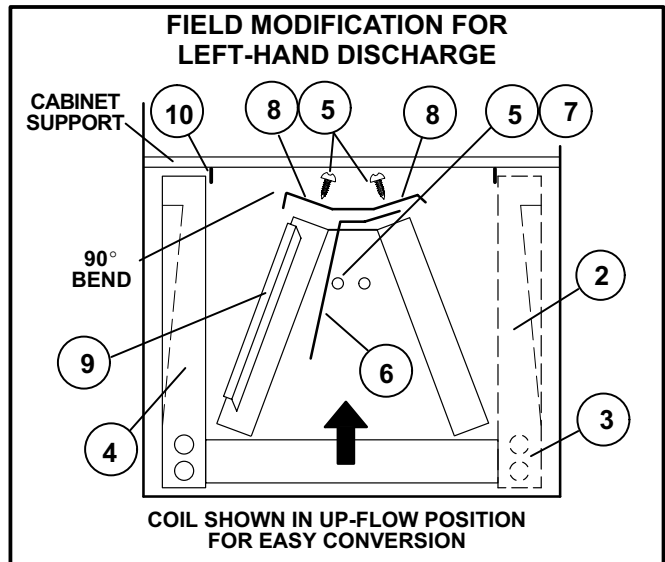

FIGURE 4

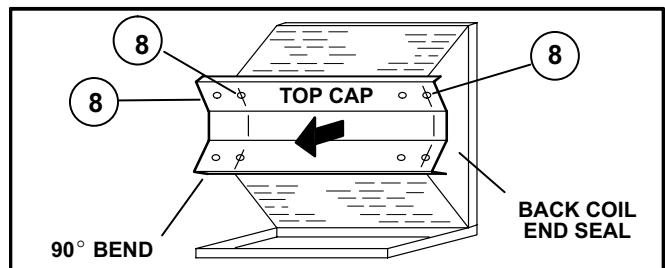

FIGURE 5

10 -From the upflow position, flip cabinet 90° to the left and set into place. Put coil assembly back in place. Secure coil in place by putting the cabinet support rail back in place. See figures 4 and 6.

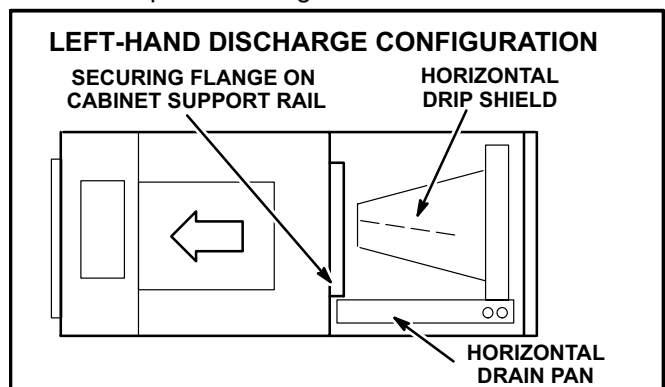

FIGURE 6

NOTE - For horizontal applications in **high humidity areas**, seal around the exiting drain pipe, liquid line and suction line to prevent infiltration of humid air.

- 11 - Knock out drain seal plate from access door. Secure plate to cabinet front flange with screw provided.
- 12 - Flip access door and replace it on the unit.
- 13 - Set unit so that it is sloped 1/4 inch toward the drain pan end of the unit. Connect return and supply air plenums as required using sheet metal screws.
- 14 - If you are going to suspend the unit, the entire length of the cabinet must be supported. If you use a chain or strap, attach a piece of angle iron or sheet metal to the unit (either above or below it), so that the full length of the cabinet is supported. Use securing screws which are no longer than 1/2 inch to avoid damaging the coil or filter. See figure 3. Use sheet metal screws to connect the return and supply air plenums.

Field Piping Connections

All CB28UH coils are equipped with a factory-installed, internally mounted expansion valve. Use Lennox L15 (sweat) series line sets as shown in table 1 or use field-fabricated refrigerant lines. L10 (flare) line sets may be used by cutting off flare nut. Refer to the piping section of the Lennox Unit Information Service Manual for proper size, type and application of field-fabricated lines.

**TABLE 1
REFRIGERANT LINE KITS**

CB28UH UNIT	LIQUID LINE	VAPOR LINE	L15 LINE SETS
-018/-024	3/8 in (8 mm)	5/8 in (16 mm)	L15-26 20 ft. - 50 ft. (6 m - 15 m)
-030/-036	3/8 in (10 mm)	3/4 in. (19 mm)	L15-41 20 ft. - 50 ft. (6 m - 15 m)
-042/-048	3/8 in (10 mm)	7/8 in. (22 mm)	L15-65 30 ft. - 50 ft. (9 m - 15 m)
-060	3/8 in (10 mm)	1-1/8 in. (29 mm)	FIELD FABRICATED

NOTE - CB28UH series evaporators use nitrogen or dry air as a holding charge. If there is no pressure when the rubber plugs are removed, check the coil or line set for leaks before installing. After installation, pull a vacuum on the line set and coil before releasing the unit charge into the system.

- 1 - Use a wet rag to protect TXV bulb (or remove it) when brazing suction line.
- 2 - Be aware of filter access panel when connecting lines. Filter must be accessible.
- 3 - Place heat shield (damp rag) against the piping plate and around the suction line connection. Heat shield

must be in place to guard against damage to the paint.

- 4 - With heat shield in place, sweat in the suction line connection to the line set. After procedure is completed, remove heat shield.
- 5 - Place heat shield against piping plate and around the liquid line connection. Sweat in the liquid line connection to the line set.
- 6 - Refer to instructions provided with outdoor unit for leak testing, evacuating and charging procedures.

Condensate Drain

Connect main condensate drain and route downward to an open drain or sump. Do not connect drain to a closed waste system. Refer to figure 7 for typical condensate trap configuration.

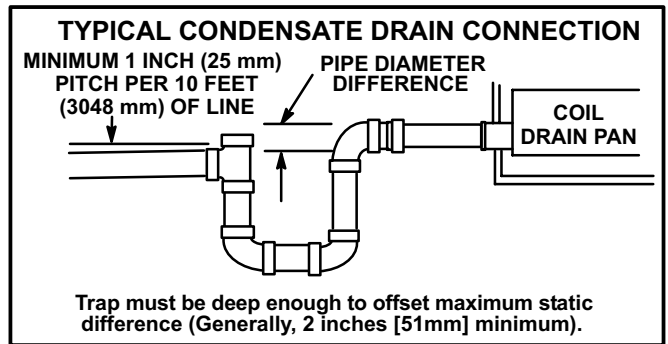

FIGURE 7

It is recommended that the auxiliary drain be connected to a drain line for all units. If auxiliary drain is not connected, it must be plugged with provided cap. See figure 8 for auxiliary and main drain locations.

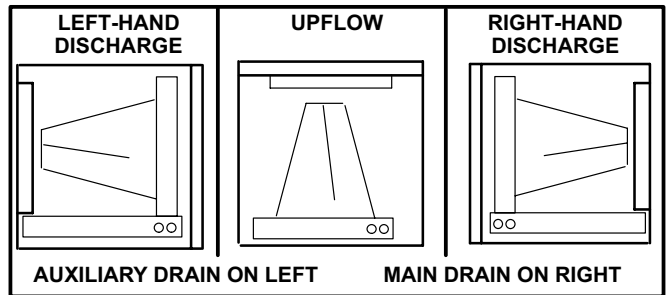

FIGURE 8

The following practices are recommended to ensure condensate removal:

- 1 - Drain piping should not be smaller than the drain connections at drain pan.
- 2 - A trap must be installed in the main drain line.
- 3 - The trap must be deep enough to offset the difference in static pressure between drain pan and atmosphere. Generally, two inches is satisfactory for medium static applications.
- 4 - Horizontal runs must be sloped 1 inch per 10 feet of drain line to offset friction.
- 5 - An open vent in drain line will sometimes be required to prevent vapor lock.

- 6 -Drains should be constructed in a manner to facilitate future cleaning and not interfere with filter access. See figure 7.
- 7 -Auxiliary drain should run to an area where homeowner will notice it draining. Refer to local codes.
- 8 -All drain connections that are not used during installation must be plugged and properly torqued to 7 ft. lbs. to prevent leaks.

Filters

⚠ IMPORTANT

Filter access panel must be in place during unit operation. Excessive warm air entering the unit may result in water blow-off problems.

Each unit includes a factory-installed filter. Note that filter access cover fits over access panel.

Filters should be inspected monthly and must be cleaned or replaced when dirty to assure proper operation.

This unit is equipped with standard throw-away type filters which should be replaced when they become dirty.

To remove filter, take off filter access door, slide filter out of the guides on either side of cabinet, insert new filter and replace the filter access door. See table 2 for replacement filter sizes.

**TABLE 2
FILTER DIMENSIONS**

UNIT MODEL NO.	FILTER SIZE Inches (mm)
CB28UH-018/-024	15 x 20 (381 x 508)
CB28UH-030/-042	20 x 20 (508 x 508)
CB28UH-048/-060	20 x 22 (508 x 559)

Sealing the Unit

It is very important to seal the unit so that warm air is not allowed into the cabinet. Warm air introduces moisture, which results in condensation problems. This is especially important when the unit is installed in an unconditioned area.

Make sure the liquid line and suction line entry points are sealed with either the provided material or with Permagum. Permagum may also be used to seal around the main and auxiliary drains and around open areas of electrical inlets.

Blower Speed Adjustments

Minimum Blower Speeds (With Electric Heaters)

For the minimum allowable speed for the CB28UH series units with electric heat, refer to the ECB29 installation instructions.

Air Volume Adjustment

Blower speed selection is accomplished by changing the taps at the harness connector at the blower motor. Refer to unit wiring diagram in figure 9. Refer to tables 3 through 8 for blower performance data.

**TABLE 3
CB28UH-018/024 BLOWER PERFORMANCE (208/230v)**

External Static Pressure		Air Volume and Motor Watts at Specific Blower Taps								
		Low			Medium			High		
in. w.g.	Pa	cfm	L/s	Watts	cfm	L/s	Watts	cfm	L/s	Watts
.00	0	700	330	245	895	420	310	1030	485	375
.05	10	690	325	240	875	415	305	1010	475	370
.10	25	680	320	235	865	410	300	990	470	365
.15	35	665	315	230	850	400	290	970	460	355
.20	50	655	310	225	830	390	285	955	450	350
.25	60	640	300	220	810	385	280	925	440	345
.30	75	625	295	220	795	375	270	900	425	335
.40	100	595	280	210	750	355	255	850	400	320
.50	125	555	260	195	700	330	240	800	380	305
.60	150	510	240	185	640	300	225	725	340	290
.70	175	395	185	165	----	----	----	620	295	265
.75	185	----	----	----	----	----	----	570	270	255

NOTE - All air data is measured external to unit with air filter in place. Electric heaters have no appreciable air resistance.

**TABLE 4
CB28UH-030 BLOWER PERFORMANCE (208/230v)**

External Static Pressure		Air Volume and Motor Watts at Specific Blower Taps								
		Low			Medium			High		
in. w.g.	Pa	cfm	L/s	Watts	cfm	L/s	Watts	cfm	L/s	Watts
.00	0	1015	480	385	1135	535	410	1230	580	450
.05	10	995	470	375	1120	530	400	1205	570	445
.10	25	980	465	365	1095	515	390	1190	560	440
.15	35	960	455	355	1075	505	380	1165	550	430
.20	50	945	445	345	1050	495	375	1140	540	425
.25	60	925	435	335	1025	485	365	1105	520	415
.30	75	900	425	325	1005	475	355	1080	510	405
.40	100	860	405	305	950	450	335	1025	485	390
.50	125	800	380	285	890	420	315	960	450	370
.60	150	740	350	265	810	385	290	875	415	350
.70	175	670	315	240	735	345	270	790	375	330
.75	185	610	290	225	675	320	255	725	340	315

NOTE - All air data is measured external to unit with air filter in place. Electric heaters have no appreciable air resistance.

**TABLE 5
CB28UH-036 BLOWER PERFORMANCE (208/230v)**

External Static Pressure		Air Volume and Motor Watts at Specific Blower Taps								
		Low			Medium			High		
in. w.g.	Pa	cfm	L/s	Watts	cfm	L/s	Watts	cfm	L/s	Watts
.00	0	935	440	420	1145	540	510	1505	710	655
.05	10	930	440	415	1140	535	500	1485	700	640
.10	25	925	435	410	1130	535	490	1475	695	630
.15	35	915	435	395	1125	530	480	1455	685	615
.20	50	910	430	390	1115	525	475	1435	680	600
.25	60	905	425	380	1110	525	465	1420	670	585
.30	75	900	425	370	1100	520	455	1395	660	570
.40	100	885	415	355	1080	510	430	1350	640	540
.50	125	865	410	335	1060	500	415	1300	615	510
.60	150	845	400	315	1030	485	390	1235	585	480
.70	175	820	390	300	-----	-----	-----	1160	550	455
.75	185	-----	-----	-----	-----	-----	-----	1015	480	425

NOTE - All air data is measured external to unit with air filter in place. Electric heaters have no appreciable air resistance.

**TABLE 6
CB28UH-042 BLOWER PERFORMANCE (208/230v)**

External Static Pressure		Air Volume and Motor Watts at Specific Blower Taps								
		Low			Medium			High		
in. w.g.	Pa	cfm	L/s	Watts	cfm	L/s	Watts	cfm	L/s	Watts
.00	0	1295	610	520	1520	720	595	1775	840	730
.05	10	1275	605	510	1505	710	585	1750	825	720
.10	25	1255	590	495	1480	700	570	1720	810	710
.15	35	1230	580	480	1455	685	555	1690	795	700
.20	50	1215	575	470	1430	675	540	1650	780	685
.25	60	1195	565	455	1405	665	525	1620	765	675
.30	75	1170	555	440	1380	650	515	1595	750	660
.40	100	1125	530	415	1320	625	485	1515	715	635
.50	125	1065	500	385	1260	595	460	1420	670	605
.60	150	1005	475	360	1175	555	425	1325	625	575
.70	175	910	430	330	1075	505	395	1210	570	545
.80	200	-----	-----	-----	-----	-----	-----	900	425	480

NOTE - All air data is measured external to unit with air filter in place. Electric heaters have no appreciable air resistance.

**TABLE 7
CB28UH-048 BLOWER PERFORMANCE (208/230v)**

External Static Pressure		Air Volume and Motor Watts at Specific Blower Taps								
		Low			Medium			High		
in. w.g.	Pa	cfm	L/s	Watts	cfm	L/s	Watts	cfm	L/s	Watts
.00	0	1590	750	665	1790	845	805	2055	970	1005
.05	10	1570	740	660	1770	835	790	2035	960	995
.10	25	1555	735	655	1750	825	785	2005	945	980
.15	35	1530	720	645	1730	815	775	1980	935	970
.20	50	1510	710	640	1710	805	765	1945	920	955
.25	60	1485	700	635	1685	795	755	1915	905	940
.30	75	1460	690	625	1660	785	745	1885	890	930
.40	100	1415	670	615	1610	760	725	1820	860	900
.50	125	1370	645	600	1550	730	705	1750	825	875
.60	150	1310	620	580	1490	705	685	1670	790	845
.70	175	1240	585	560	1405	665	660	1575	745	820
.75	185	1210	570	550	1360	640	645	1520	720	800

NOTE - All air data is measured external to unit with air filter in place. Electric heaters have no appreciable air resistance.

**TABLE 8
CB28UH-060 BLOWER PERFORMANCE (208/230v)**

External Static Pressure		Air Volume and Motor Watts at Specific Blower Taps														
		Low			Medium-Low			Medium			Medium-High			High		
in. w.g.	Pa	cfm	L/s	Watts	cfm	L/s	Watts	cfm	L/s	Watts	cfm	L/s	Watts	cfm	L/s	Watts
.00	0	1570	740	575	1800	850	700	2005	945	825	2135	1005	930	2245	1060	1080
.05	10	1550	730	570	1780	840	690	1980	935	815	2110	995	925	2220	1050	1070
.10	25	1530	725	560	1760	830	680	1950	920	805	2080	985	915	2190	1035	1060
.15	35	1520	715	560	1735	820	670	1930	910	795	2055	970	905	2165	1020	1050
.20	50	1495	705	550	1710	805	660	1910	900	790	2025	955	895	2135	1010	1040
.25	60	1475	695	545	1690	795	655	1880	890	780	1995	940	885	2105	995	1030
.30	75	1460	690	540	1670	785	650	1855	875	770	1965	930	875	2075	980	1020
.40	100	1415	670	530	1615	760	630	1795	850	750	1910	900	855	2005	945	995
.50	125	1370	645	520	1560	735	615	1735	820	730	1850	875	835	1935	910	975
.60	150	1310	620	505	1495	705	595	1670	790	710	1780	840	810	1855	875	950
.70	175	1250	590	490	1425	675	575	1600	755	690	1705	805	785	1780	840	925
.80	200	1175	555	470	1360	640	560	1520	715	665	1620	765	755	1685	795	900
.90	225	1025	485	440	1280	605	545	1420	670	645	1520	715	725	1595	750	875
.95	235	-----	-----	-----	1240	585	535	1365	645	630	1460	690	705	1545	730	860

NOTE - All air data is measured external to unit with air filter in place. Electric heaters have no appreciable air resistance.

Electrical

WARNING

USE COPPER CONDUCTORS ONLY.

Wiring must conform to the current National Electric Code ANSI/NFPA No. 70, or Canadian Electric Code Part I, CSA Standard C22.1, and local building codes. Refer to following wiring diagrams. See unit nameplate for minimum circuit ampacity and maximum overcurrent protection size.

Select the proper supply circuit conductors in accor-

dance with tables 310-16 and 310-17 in the National Electric Code, ANSI/NFPA No. 70 or tables 1 through 4 in the Canadian Electric Code, Part I, CSA Standard C22.1.

This unit is provided with knockout for conduit. Refer to figure 9 for unit schematic wiring diagram.

Separate openings have been provided for 24V low voltage and line voltage. Refer to the dimension illustration for specific location.

WARNING

Run 24V Class II wiring only through specified low voltage opening. Run line voltage wiring only through specified high voltage opening. Do not combine voltage in one opening.

CB28UH Typical Wiring Diagram - Single Phase

FIELD WIRING FOR ECB SERIES UNITS WITHOUT CIRCUIT BREAKERS

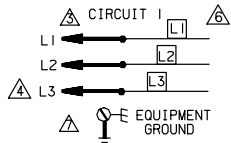

⚠ L3 IS NOT PRESENT ON (P) ELECTRIC HEATERS
 ⚠ THE NUMBER OF CIRCUITS VARY ACCORDING TO HEATER MODEL. REFER TO FAN COIL NAMEPLATE FOR ACTUAL NUMBER EMPLOYED

FIELD WIRING FOR ECB SERIES UNITS WITH CIRCUIT BREAKERS

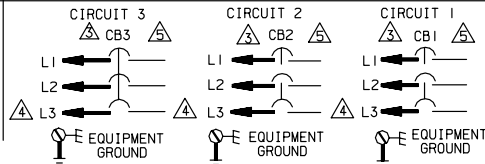

⚠ EQUIPMENT GROUND LOCATED IN INDOOR UNIT
 ⚠ CONNECT POWER WIRES FROM HEATER LABELED L1, L2 ON "P" VOLTAGE UNITS AND L1, L2, L3 ON "Y" VOLTAGE UNITS TO TB2 TERMINAL STRIP IN INDOOR UNIT.

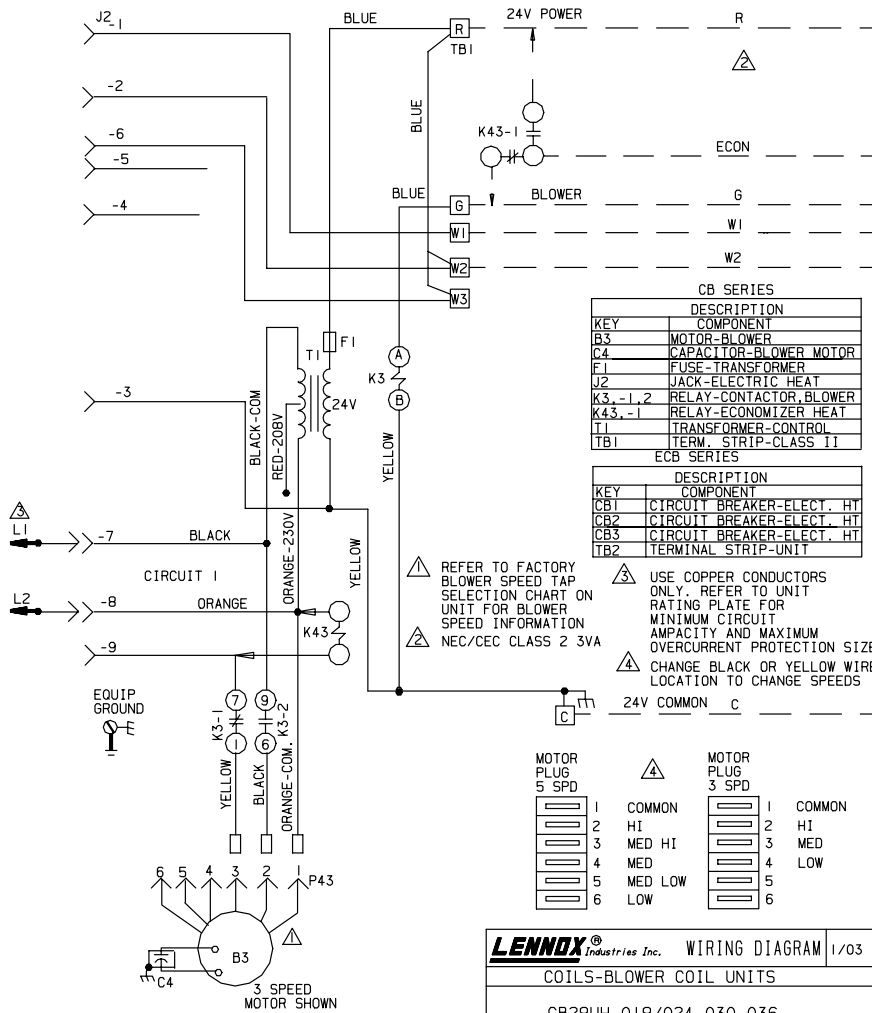

KEY	DESCRIPTION
COMPONENT	
B3	MOTOR-BLOWER
C4	CAPACITOR-BLOWER MOTOR
F1	FUSE-TRANSFORMER
J2	JACK-ELECTRIC HEAT
K3, -1, 2	RELAY-CONTACTOR, BLOWER
K43, -1	RELAY-ECONOMIZER HEAT
T1	TRANSFORMER-CONTROL
TB1	TERM. STRIP-CLASS II

KEY	DESCRIPTION
COMPONENT	
CB1	CIRCUIT BREAKER-ELECT. HT
CB2	CIRCUIT BREAKER-ELECT. HT
CB3	CIRCUIT BREAKER-ELECT. HT
TB2	TERMINAL STRIP-UNIT

⚠ REFER TO FACTORY BLOWER SPEED TAP SELECTION CHART ON UNIT FOR BLOWER SPEED INFORMATION
 NEC/CEC CLASS 2 3VA
 ⚠ USE COPPER CONDUCTORS ONLY. REFER TO UNIT RATING PLATE FOR MINIMUM CIRCUIT AMPACITY AND MAXIMUM OVERCURRENT PROTECTION SIZE.
 ⚠ CHANGE BLACK OR YELLOW WIRE LOCATION TO CHANGE SPEEDS

MOTOR PLUG	5 SPD	4	MOTOR PLUG	3 SPD
1	COMMON	1	COMMON	
2	HI	2	HI	
3	MED HI	3	MED	
4	MED	4	LOW	
5	MED LOW	5		
6	LOW	6		

— LINE VOLTAGE FIELD WIRING
 - - CLASS II VOLTAGE FIELD WIRING

LENNOX Industries Inc. WIRING DIAGRAM 1/03
 COILS-BLOWER COIL UNITS
 CB28UH-018/024, 030, 036, 042, 048, 060-230
 COIL SECTION-
 Supersedes Form No. _____ New Form No. 534, 335W
 © 2003 Litho U.S.A.

FIGURE 9

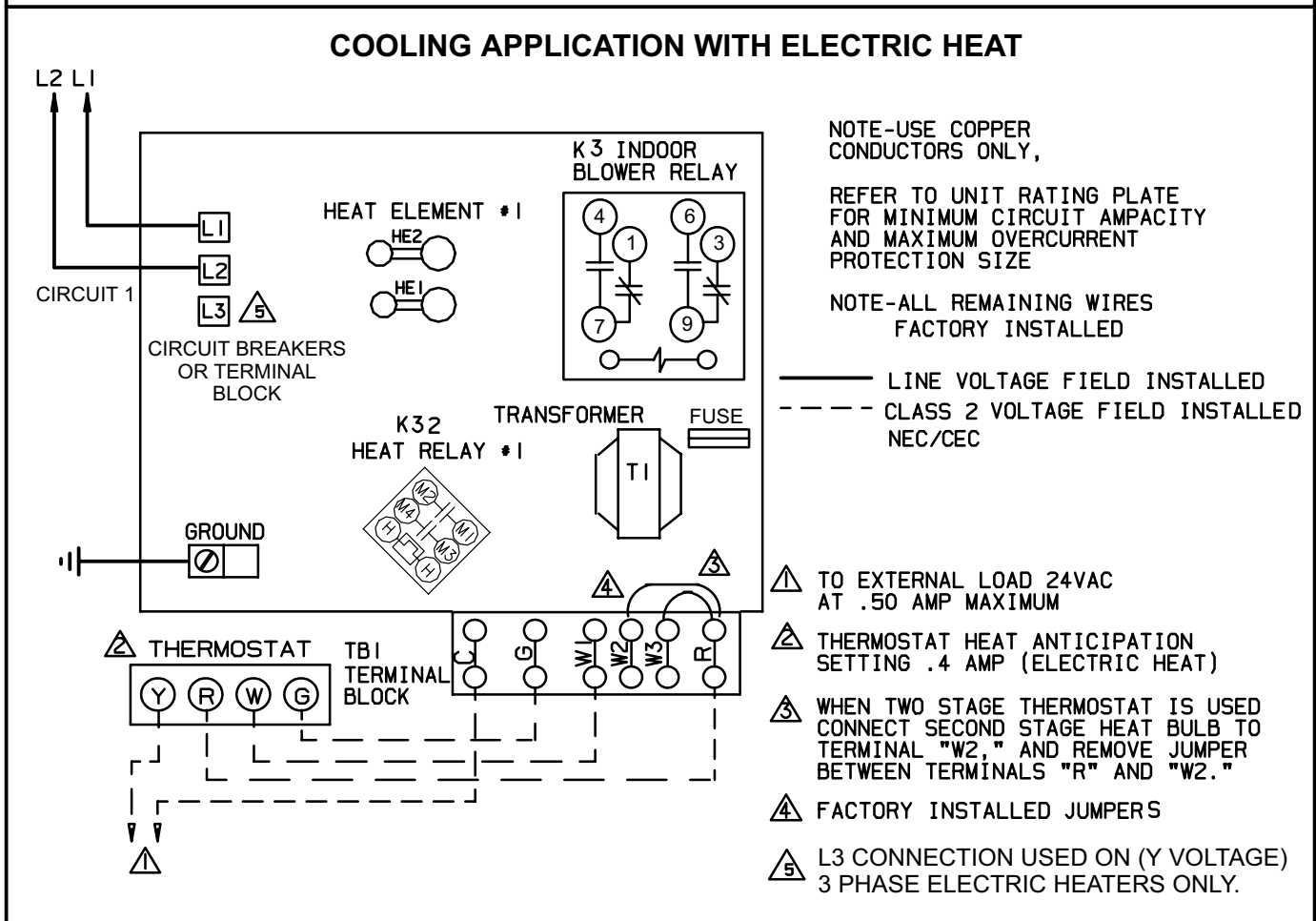
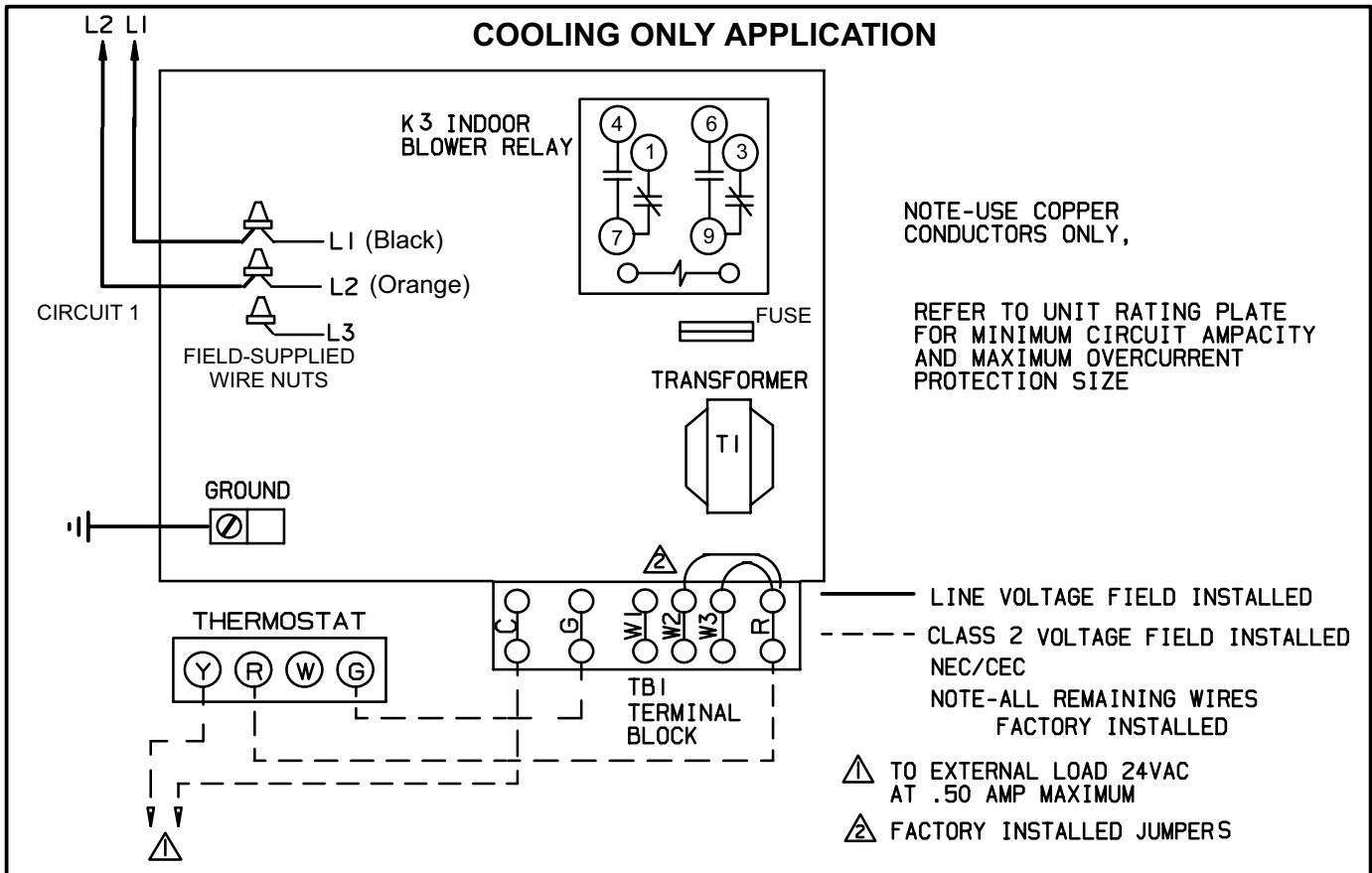

FIGURE 10

HEAT PUMP ONLY APPLICATION

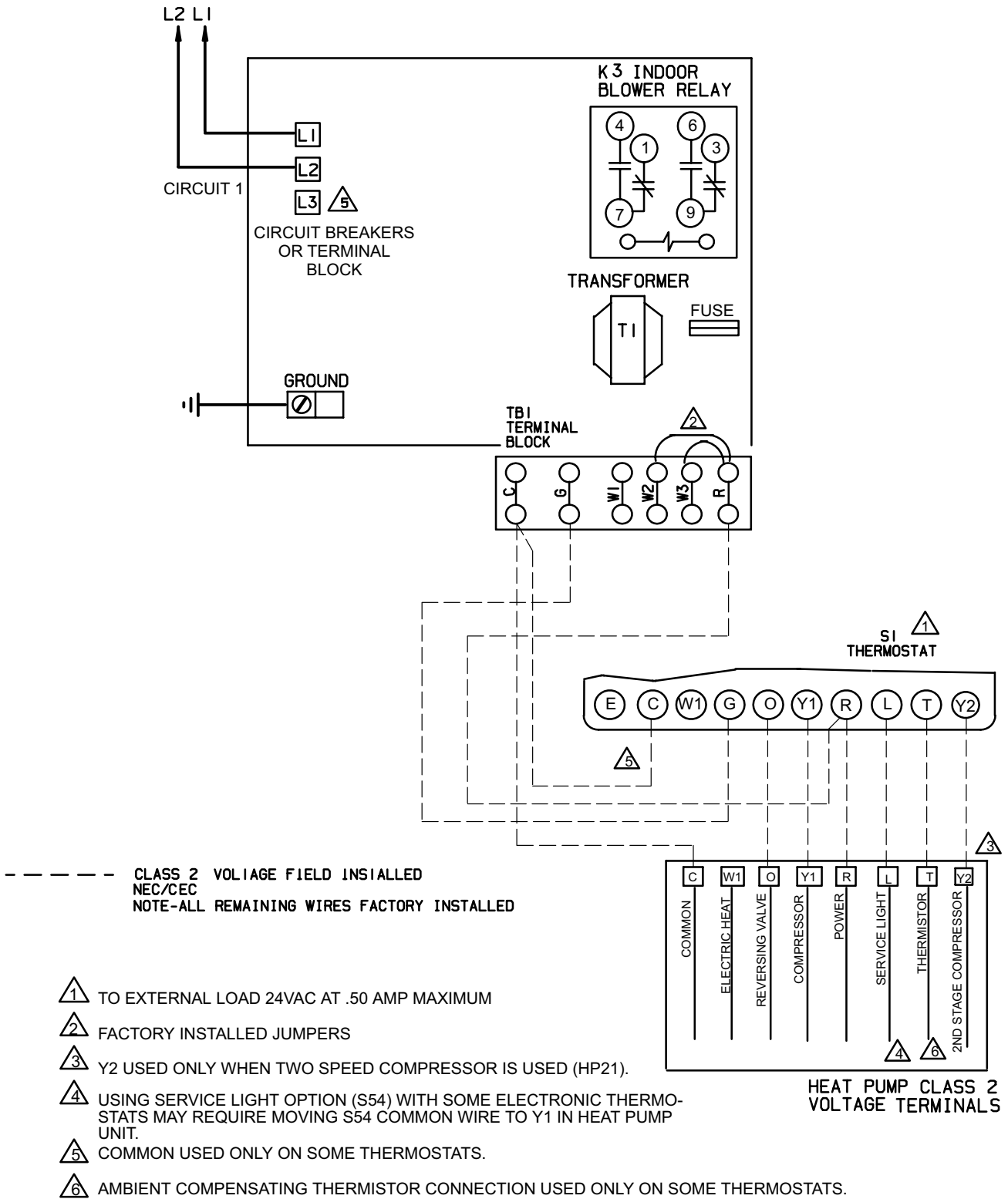

FIGURE 11

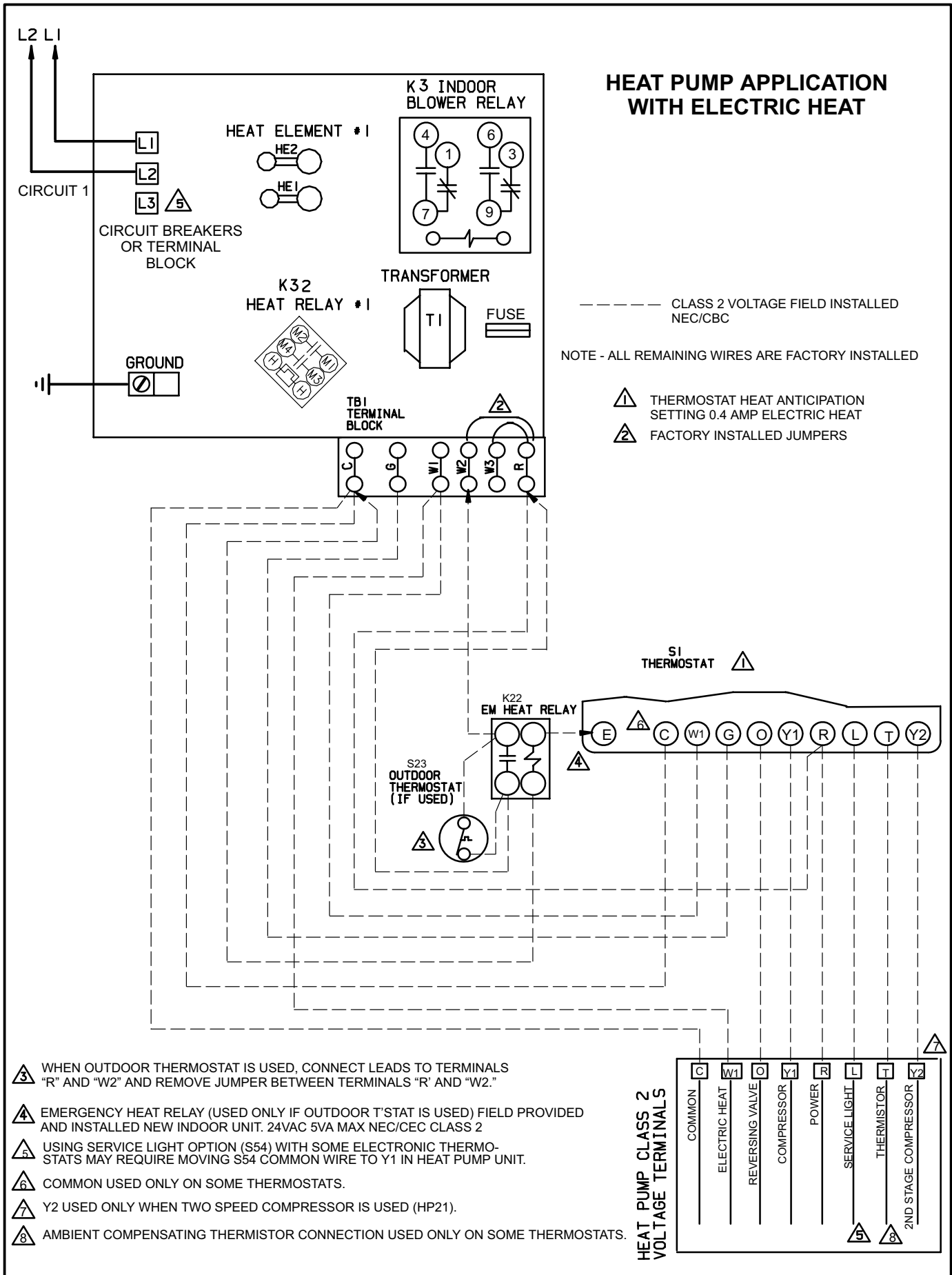

FIGURE 12