

G20 SERIES UNITS

I-INTRODUCTION/APPLICATION

G20 and G20E series units are mid-efficiency gas furnaces manufactured with Duracurvet heat exchangers formed of either cold rolled or aluminized steel. G20 units come in heating capacities of 50,000 to 150,000 Btuh and cooling applications up to 6 tons. Refer to Engineering Handbook for proper sizing.

Units are factory supplied for use with natural gas. A kit is available for conversion to LPG operation. The G20 unit is equipped with a standing pilot. G20E units use an electronic ignition. G20X units use electronic ignition and meet the California Nitrogen Oxides (NO_x) Standards and California Seasonal Efficiency requirements. G20X series units use only natural gas. All units use a redundant gas valve to assure safety shut-off as required by A.G.A.

Featured on G20 series is a burner box damper assembly located on the intake side of the burners. A damper door in the burner box shuts during unit off cycles to retain heat in the unit. A damper prove switch ensures that damper is open before gas valve is energized. Since the G20 furnaces have atmospheric burners there is no induced draft motor. All G20 units use a draft diverter which allows the use of standard single wall vent connectors.

This manual is divided into sections which discuss the major components, electronic ignition module, maintenance and operation sequences.

All specifications in this manual are subject to change.

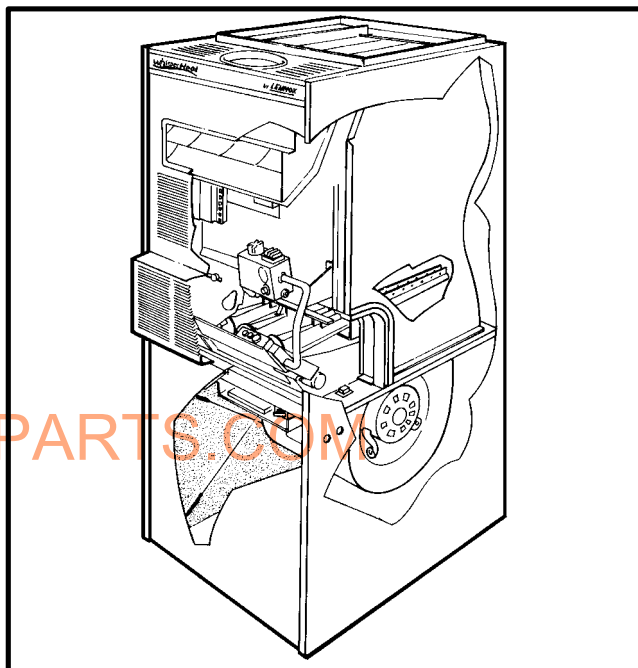

SPECIFICATIONS(continued on next page)

Model No.	G20Q2-50	G20Q3-50	G20Q3-75	G20Q4-75	G20Q3/4-100
Input Btuh	50,000	50,000	75,000	75,000	100,000
Output Btuh	40,000	40,000	59,000	60,000	79,000
*A.F.U.E.	77.0%	77.0%	77.0%	77.0%	78.0%
Flue connection (in. diameter)	4	4	4	4	5
Temperature rise range	25-55	25-55	35-65	25-55	35-65
High static certified by A.G.A.(in wg.)	.50	.50	.50	.50	.50
Gas piping size I.P.S. (in.)	Natural	1/2	1/2	1/2	1/2
	LPG	1/2	1/2	1/2	1/2
Blower wheel nominal diameter x width (in.)	9 x 7	10 x 7	10 x 7	10 x 8	10 x 8
Blower motor hp	1/4	1/3	1/3	1/2	1/2
Tons of cooling (add-on)	1, 1-1/2, 2	2-1/2 or 3	2-1/2 or 3	3-1/2 or 4	3, 3-1/2, 4
Number and size of filters (in.)	(1) 16 x 25 x 1				
**Optional LPG Conversion Kit	LB-62384DA				
Electrical characteristics	120 volts — 60 hertz — 1 phase (less than 12 amps) — All Models				

*Annual Fuel Utilization Efficiency based on D.O.E. test procedures and according to F.T.C. labeling requirements. Isolated combustion system rating for non-weatherized furnaces.
**LPG kit must be ordered extra for field changeover.

SPECIFICATIONS (continued from previous page)

Model No.	G20Q5/6-100	G20Q3-125	G20Q4/5-125	G20Q5/6-150
Input Btuh	100,000	125,000	125,000	150,000
Output Btuh	79,000	100,000	99,000	115,000
*A.F.U.E.	78.0%	77.0%	78.0%	78.0%
Flue connection (in. diameter)	5	6	6	6
Temperature rise range	25-55	70-100	35-65	40-70
High static certified by A.G.A.(in wg.)	.75	.50	.50	.50
Gas piping size I.P.S. (in.)	Natural	1/2	1/2	1/2
	LPG	1/2	1/2	1/2
Blower wheel nominal diameter x width (in.)	12 x 12	10 x 8	12 x 12	12 x 12
Blower motor hp	3/4	1/3	3/4	3/4
Tons of cooling (add-on)	5 or 6	2-1/2 or 3	4 or 5	5 or 6
Number and size of filters (in.)	(1) 20 x 25 x 1			
**Optional LPG Conversion Kit	LB-62384DA			
Electrical characteristics	120 volts — 60 hertz — 1 phase (less than 12 amps) — All Models			

Model No.	◆ G20Q2E-50 ◆ G20Q2X-50	◆ G20Q3E-50 ◆ G20Q3X-50	◆ G20Q3E-75 ◆ G20Q3X-75	◆ G20Q4E-75 ◆ G20Q4X-75	◆ G20Q3/4E-100 ◆ G20Q3/4X-100
Input Btuh	50,000	50,000	75,000	75,000	100,000
Output Btuh	39,000	39,000	59,000	60,000	78,000
*A.F.U.E.	80.0%	80.0%	80.0%	80.0%	80.0%
Output Btuh—"X" models	39,000	39,000	59,000	60,000	78,000
*A.F.U.E.—"X" models	80.0%	80.0%	80.0%	80.0%	80.0%
California Seasonal Efficiency—"X" models	75.1%	74.2%	76.0%	75.3%	76.0%
Flue connection (in. diameter)	4	4	4	4	5
Temperature rise range	25-55	25-55	35-65	25-55	35-65
High static certified by A.G.A.(in wg.)	.50	.50	.50	.50	.50
Gas piping size I.P.S. (in.)	Natural	1/2	1/2	1/2	1/2
	LPG	1/2	1/2	1/2	1/2
Blower wheel nominal diameter x width (in.)	9 x 7	10 x 7	10 x 7	10 x 8	10 x 8
Blower motor hp	1/4	1/3	1/3	1/2	1/2
Tons of cooling (add-on)	1, 1-1/2, 2	2-1/2 or 3	2-1/2 or 3	3-1/2 or 4	3, 3-1/2, 4
Number and size of filters (in.)	(1) 16 x 25 x 1				
**Optional LPG Conversion Kit	LB-62384DB				
Electrical characteristics	120 volts — 60 hertz — 1 phase (less than 12 amps) — All Models				

Model No.	◆ G20Q5/6E-100 ◆ G20Q5/6X-100	◆ G20Q3E-125 ◆ G20Q3X-125	◆ G20Q4/5E-125 ◆ G20Q4/5X-125	◆ G20Q5/6E-150 ◆ G20Q5/6X-150
Input Btuh	100,000	125,000	125,000	150,000
Output Btuh	78,000	95,000	97,000	116,000
*A.F.U.E.	80.0%	79.5%	80.0%	80.0%
Output Btuh—"X" models	78,000	95,000	97,000	116,000
*A.F.U.E.—"X" models	80.0%	79.5%	80.0%	80.0%
California Seasonal Efficiency—"X" models	75.0%	77.0%	76.1%	75.7%
Flue connection (in. diameter)	5	6	6	6
Temperature rise range	25-55	70-100	35-65	40-70
High static certified by A.G.A.(in wg.)	.75	.50	.50	.50
Gas piping size I.P.S. (in.)	Natural	1/2	1/2	1/2
	LPG	1/2	1/2	1/2
Blower wheel nominal diameter x width (in.)	12 x 12	10 x 8	12 x 12	12 x 12
Blower motor hp	3/4	1/3	3/4	3/4
Tons of cooling (add-on)	5 or 6	2-1/2 or 3	4 or 5	5 or 6
Number and size of filters (in.)	(1) 20 x 25 x 1			
*Optional LPG Conversion Kit	LB-62384DB			
Electrical characteristics	120 volts — 60 hertz — 1 phase (less than 12 amps) — All Models			

*Annual Fuel Utilization Efficiency based on D.O.E. test procedures and according to F.T.C. labeling requirements. Isolated combustion system rating for non-weatherized furnaces.
 **LPG kit must be ordered extra for field changeover.
 ◆ Not available with LPG.

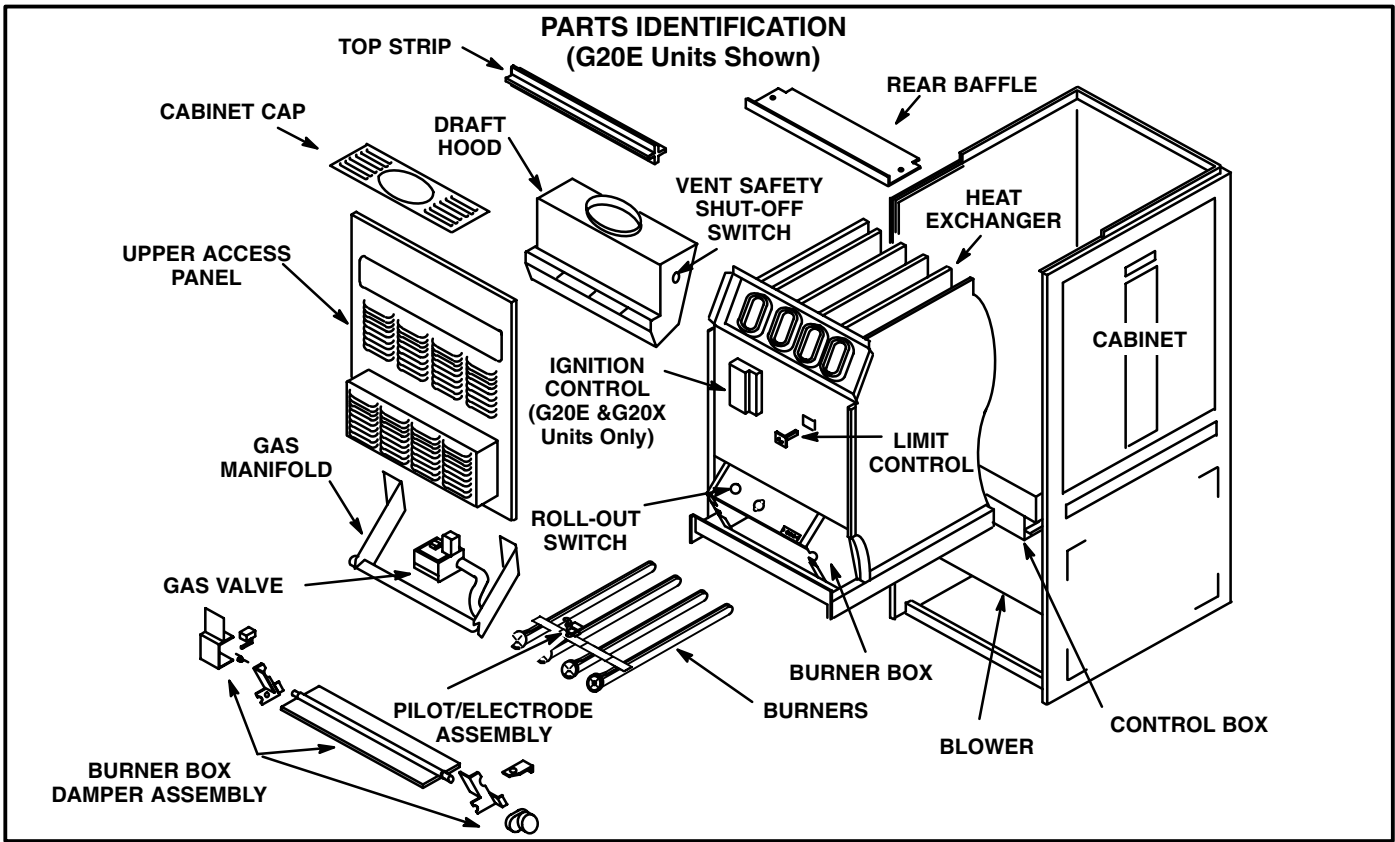

FIGURE 1

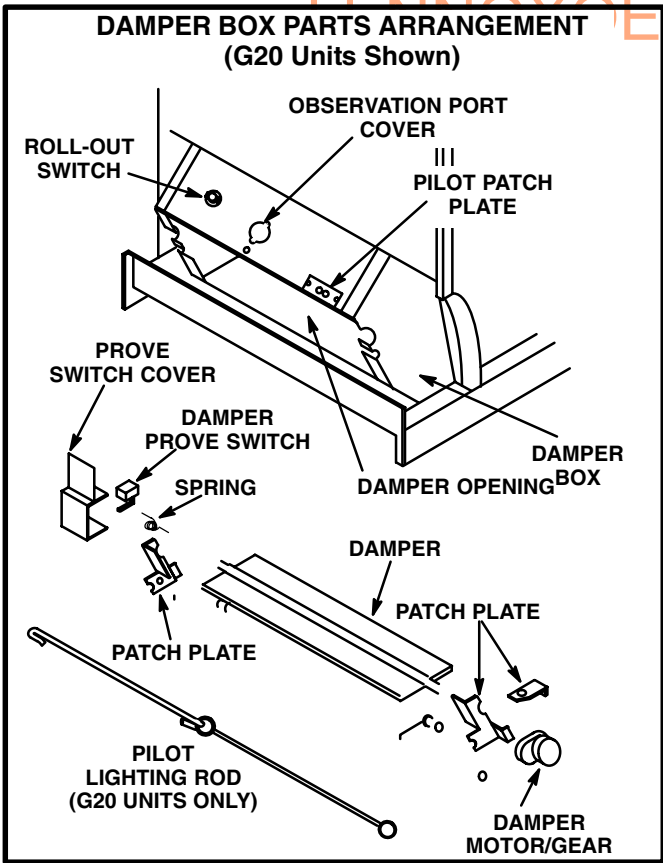

FIGURE 2

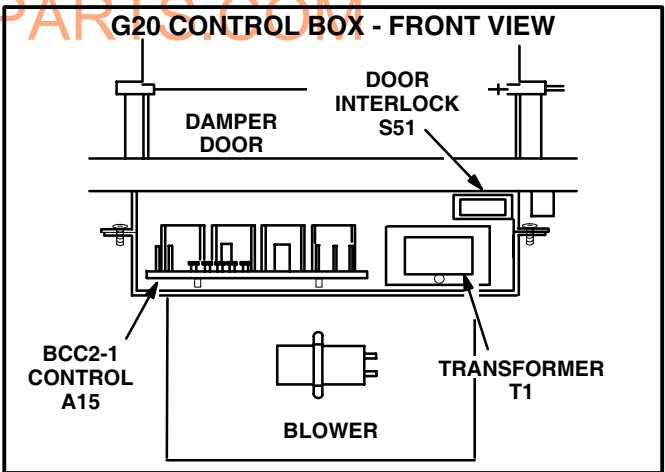

FIGURE 3

II-UNIT COMPONENTS

A-Control Box (Figure 3)

On G20 series units the unit control box is located in the blower compartment between the burner box and the blower housing. The hinged control box can be lowered for service access by removing two securing screws, one located on either side. At the top right corner of the control box is the door interlock switch (S51).

Housed in the control box are the unit transformer (T1) and the BCC2-1 blower control (A15).

1- Control Transformer (T1)

A transformer located inside the control box provides power to the low voltage section of the unit. Transformers on all models are rated 30VA with a 120V primary and a 24V secondary.

2- BCC2-1 through BCC3-2 Blower Control (A15)

All G20 units utilize the BCC blower control. The BCC is a printed circuit board which controls the blower and monitors primary limit and gas valve operation. The control has a non-adjustable, factory preset "on" fan timing. Fan "off" timings are adjustable. The board is divided into two sections, 120 and 24VAC. Line voltage comes into the board on the 120VAC side. See figure 4.

"CAB" and "XFMR" send 120VAC to the damper motor and transformer, respectively. The active cooling and heating blower speed terminals and three dummy "D" terminals are located on the 120VAC side of the BCC. Also located on the 120VAC side of the control are neutral terminals and a terminal for accessories such as an electronic air cleaner. The "HSI" terminal is not used.

24VAC comes from the transformer into terminal "24V" on the 24VAC side of the BCC. Thermostat connections and safety circuit terminals are also located on the 24VAC side of the control. Fan "off" timings may be adjusted by changing the position of a jumper across terminal pins. Thermostat terminal strips on early model BCC boards are removable.

able. Late model boards have permanent thermostat strips.

Blower Speed Taps

Blower speed tap changes are made on the BCC blower control board at the upper right corner. See figure 4. Unused speed taps must be secured to the dummy "D" terminals on the BCC. The active heating tap is connected to the "H" terminal and the active cooling tap is connected to the "A" terminal.

Table 1 shows the blower motor tap colors for each speed. To change a heating speed tap, turn off power, remove existing speed tap from the "H" terminal and place on "D" terminal. Next select new speed wire and place on "H" terminal of the blower control and restore power. Blower speed tap information can also be found on the G20 unit wiring diagram.

TABLE 1

BLOWER SPEED SELECTION			
SPEED	BLOWER MOTOR LEAD		
	Q2-50 Q3-75	Q3-50, Q4-75 Q3/4-100 Q3-125	Q5/5-100 Q4/5-125 Q5/6-150
LOW	RED	RED	RED
MEDIUM LOW	-	YELLOW	YELLOW
MEDIUM	YELLOW	-	BLUE
MEDIUM HI	-	BROWN	BROWN
HIGH	BLACK	BLACK	BLACK

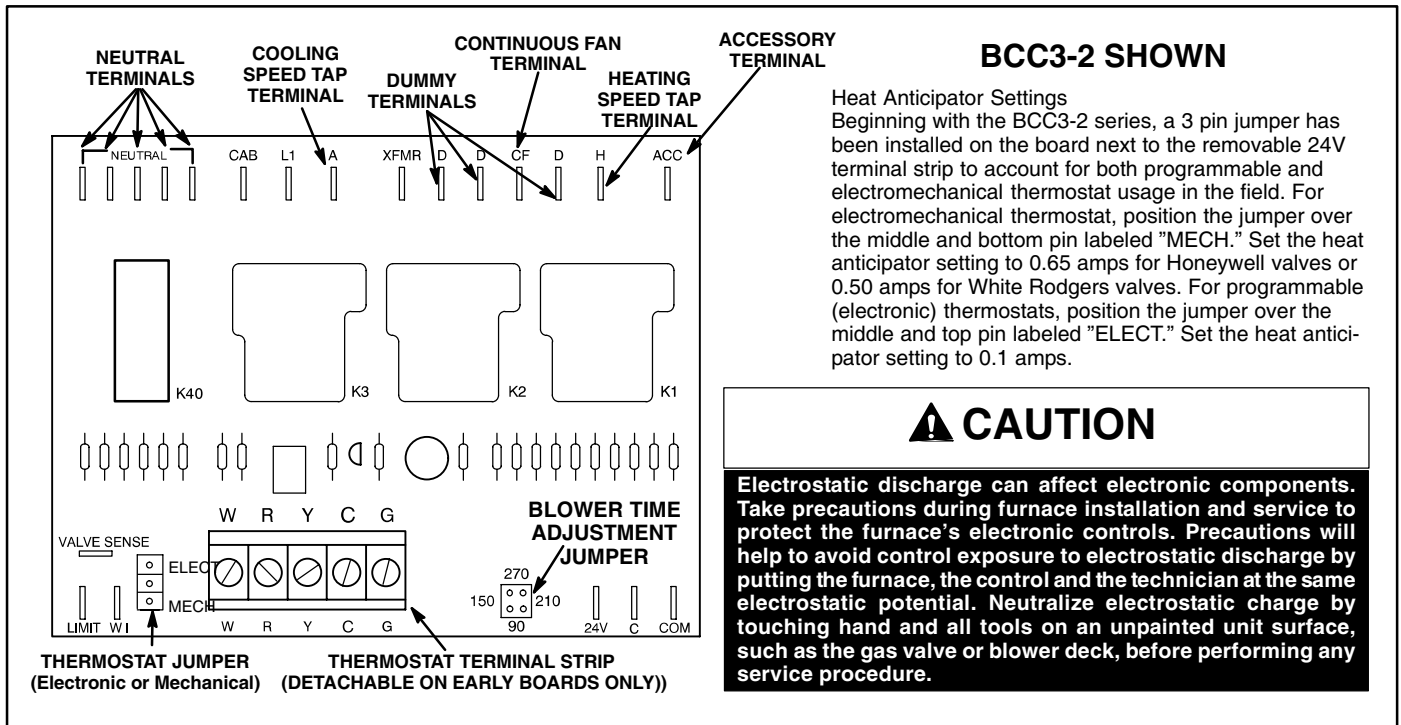

FIGURE 4

Fan Timings

WARNING—MAKE SURE TO DISCONNECT POWER BEFORE CHANGING FAN “OFF” TIMINGS.

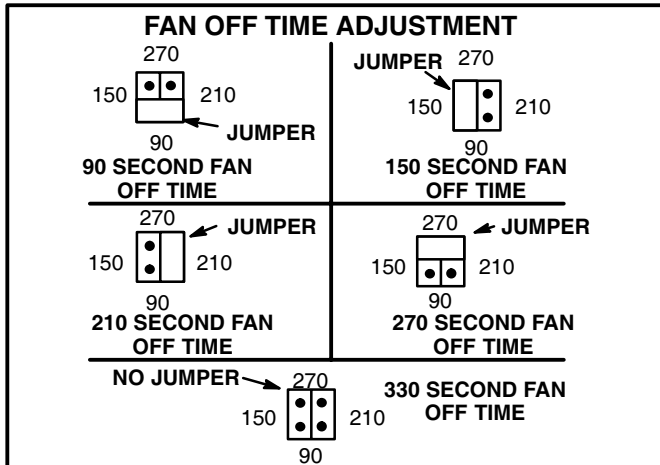

FIGURE 5

NOTE—IF FAN “OFF” TIME IS SET TOO LOW, RESIDUAL HEAT IN HEAT EXCHANGER MAY CAUSE PRIMARY LIMIT S10 TO TRIP RESULTING IN FREQUENT CYCLING OF BLOWER. IF THIS OCCURS, ADJUST BLOWER TO LONGER TIME SETTING.

Fan “off” timings (time that the blower operates after the heat demand has been satisfied) are determined by the arrangement of a jumper across pins on the BCC blower control board. See figure 4. To adjust fan “off” timings, gently disconnect jumper and reposition across pins corresponding with new timing. Fan “on” time is factory set at 45 seconds and is not adjustable.

Figure 5 shows the various fan “off” timings and how jumper should be positioned. Unit is shipped with a factory fan “off” setting of 90 seconds. Fan “off” time will affect comfort and efficiency and is adjustable to satisfy individual applications.

B-Blocked Vent Switch (S62)

The blocked vent switch (S62) is located on the right side of the draft diverter. The switch is a temperature switch that opens when there is excess heat in the draft diverter. Excess heat in the draft diverter can be caused by a blocked vent.

C-Flame Rollout Switch (S47)

The flame rollout switch is mounted on top of the burner box. The switch opens when it senses excess heat due to rollout. Rollout can be caused by a clogged heat exchanger or a blocked flue. To manually reset a tripped switch, push the red reset button.

D-Limit Control (S10)

The primary limit switch (S10) on all G20 units is located in the middle of the heating vestibule wall. When excess heat is sensed in the heat exchanger, the limit switch will open and interrupt the current to the gas valve. If the limit is tripped, the BCC energizes the blower. The limit automatically resets when unit temperature returns to normal. Table 2 gives the temperature at which the limit trips on a temperature rise and then closes on a temperature fall.

TABLE 2

PRIMARY LIMIT TEMPERATURES		
UNIT MODEL NO.	TEMP. RISE	TEMP. FALL
G20Q2-50 Series	140°F ± 5°F	110°F ± 10°F
G20Q3-75 Series G20Q3-50 Series	180°F ± 5°F	150°F ± 8°F
G20Q4-75 Series	175°F ± 5°F	145°F ± 10°F
G20Q3/4-100 Series	180°F ± 5°F	150°F ± 10°F
G20Q5/6-100 Series	250°F ± 5°F	220°F ± 8°F
G20Q3-125 Series	170°F ± 5°F	140°F ± 10°F
G20Q4/5-125 Series	180°F ± 5°F	150°F ± 10°F
G20Q5/6-150 Series	200°F ± 5°F	170°F ± 8°F

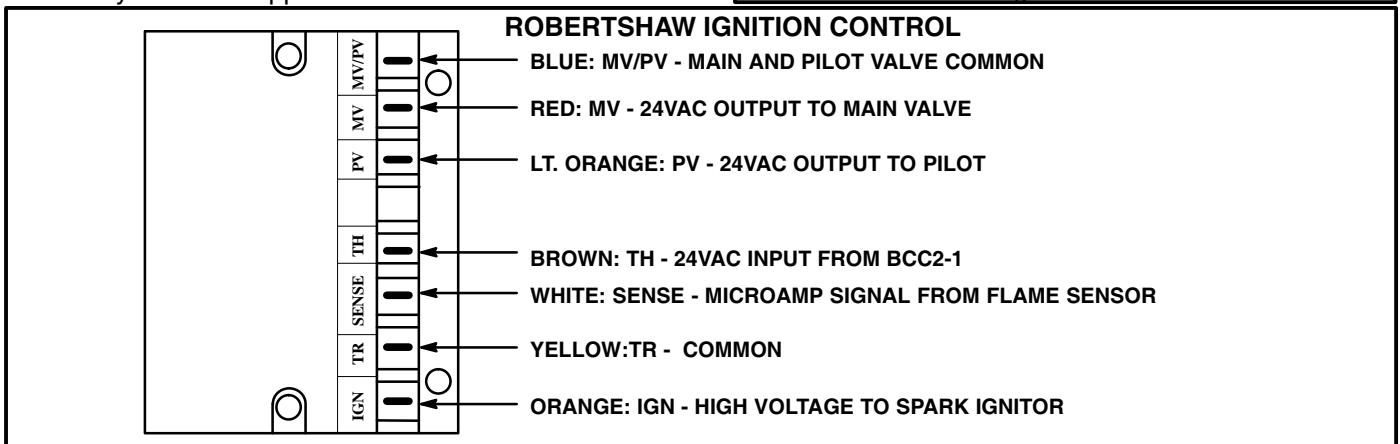

FIGURE 6

E-Robertshaw Electronic Ignition

The Robertshaw electronic ignition is an intermittent ignition control module located on the vestibule panel. See figure 1. When there is a call for heat, the control generates a spark to ignite the pilot, after which the control senses the flame. If the flame current is too weak (less than 1 micro-amp) the control will shutdown and de-energize the gas valve. Flame current should be between 1 and 5 micro-amps. See figure 6.

DANGER—SHOCK HAZARD. SPARK RELATED COMPONENTS CONTAIN HIGH VOLTAGE. DISCONNECT POWER BEFORE SERVICING UNIT. THE IGNITION CONTROL IS NOT FIELD REPAIRABLE. UNSAFE OPERATION MAY RESULT.

F-Gas Valve

The gas valves used on G20 series units have various opening times. The G20E unit with electronic ignition uses a Robertshaw gas valve and the G20 standing pilot unit uses a Honeywell gas valve. See specific sections below. All gas valves are internally redundant to assure safety shut-off. If the gas valve must be replaced, the same type valve must be used.

a-Robertshaw Gas Valve (Figure 7)

The redundant Robertshaw gas valve is used on electronic ignition G20E/G20X series units.

The 24VAC terminals and the gas knob are located on top of the valve. All terminals on the gas valve are connected to wires from the electronic ignition control. The left red wire to terminal "P" energizes the pilot valve. An orange sensing wire from terminal "V" (marked VALVE SENSE) of the BCC2-1 control rides "piggy back" on the "P" terminal connection. The main valve, terminal "M", is energized by the right red wire. The blue wire, terminal "C", is the common for the gas valve.

The inlet pressure tap is located at the top left corner of the valve. The outlet pressure tap is located in the middle of the gas valve in front of the terminal connections. The pilot adjusting screw (left) and the regulator adjustment screw (right) are located at the lower right corner of the valve. Refer to figure 7 for exact location of valve features.

An LPG changeover kit is available from Lennox. The kit includes main and pilot burner orifices, burner air adjustment shutters and a regulating conversion kit.

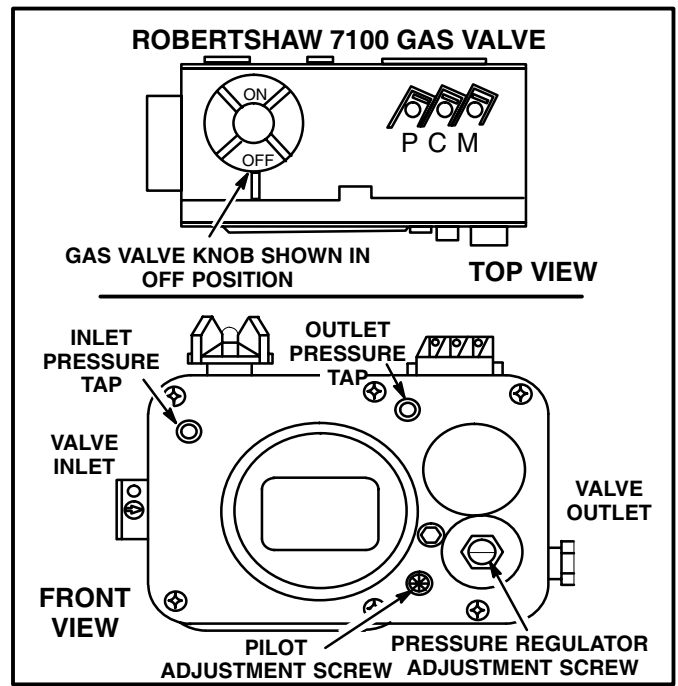

FIGURE 7

b-Pilot Tube, Ignition Wire and Flame Rod

The pilot tube from the gas valve and the flame sensor and ignition wires from the electronic ignition control enter through the top of the burner box to the pilot burner assembly.

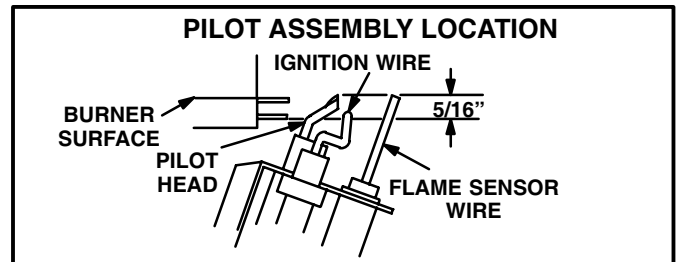

FIGURE 8

Figure 8 shows the clearance between top of the pilot burner head and the top of the main burner surface.

c-Honeywell Gas Valve (Figure 9)

The redundant Honeywell gas valve is used on G20 standing pilot units. The 24VAC terminals marked "TH" and "TR" and the gas knob are located on top of the valve.

An LPG changeover kit is available from Lennox. The kit includes main and pilot burner orifices, burner air adjustment shutters and a regulating conversion kit.

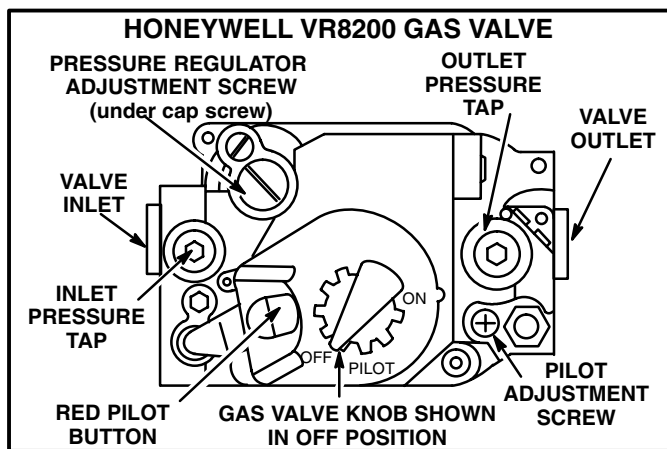

FIGURE 9

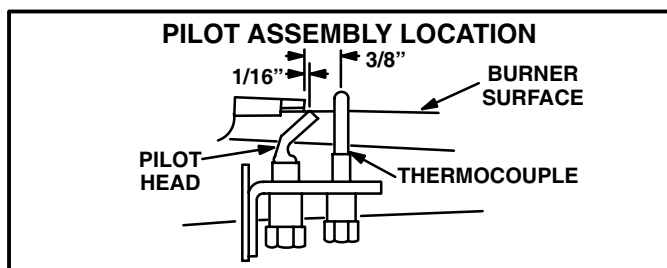

FIGURE 10

d-Pilot Tube and Thermocouple

The pilot tube and thermocouple from the gas valve enter through the top of the burner box to the pilot burner assembly.

Figure 10 shows the clearance relation of the thermocouple and pilot tube to the top of main burner surface.

II-BURNER BOX ASSEMBLY

A-Burner Box / Damper Door

The damper motor is located on the right side of the burner box. On the left side of the burner box, behind a protective plate is the damper prove switch. Refer to figure 2. The top of the burner box top is removable on later units.

When there is a call for heat, the damper motor is energized and damper door opens as the damper motor axle begins to rotate.

B-Damper Prove Switch (S64)

The spring, which is held by a notch in the burner box frame, activates the damper prove switch as the damper door opens. See figure 11. The axle rotates the damper door to open position. As the axle turns, the spring winds backwards to make contact with the damper prove switch.

The protective cover plate is removable (two screws) and the spring may be unclipped for service to the damper door or burner box. Spring must be removed in order to remove the damper door.

After service is complete, the spring must rest snugly in notch for damper prove switch to function properly. Do not force door open, damage to the spring and motor may occur. Take care to open damper door slowly.

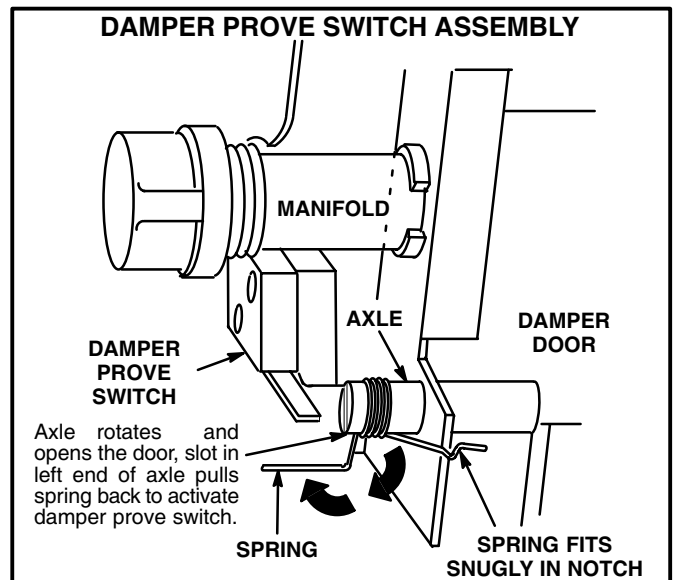

FIGURE 11

III-BLOWER AND FILTER

A-Blower Motors and Capacitors

All G20 units use direct drive blower motors. All motors used are 120V permanent split capacitor motors to ensure maximum efficiency. See table 1 for blower speed tap selection.

B-Filters and Filter Springs

G20 units use a cleanable hogshair-type filter. Holding springs lock filter in place by securing hook in holes provided in unit. All units are factory shipped for side air return. Bottom filter applications for use on G20Q5/6-100, G20 Q3-125, G20Q4/5-125 and G20Q5/6-150 require an optional kit available from Lennox. See figure 12.

IV-MAINTENANCE

At the beginning of each heating season, the system should be checked as follows:

A-Supply Air Blower

- 1- Check and clean blower wheel.
- 2- Motors used on the Lennox G20 series units are permanently lubricated and need no further lubrication.

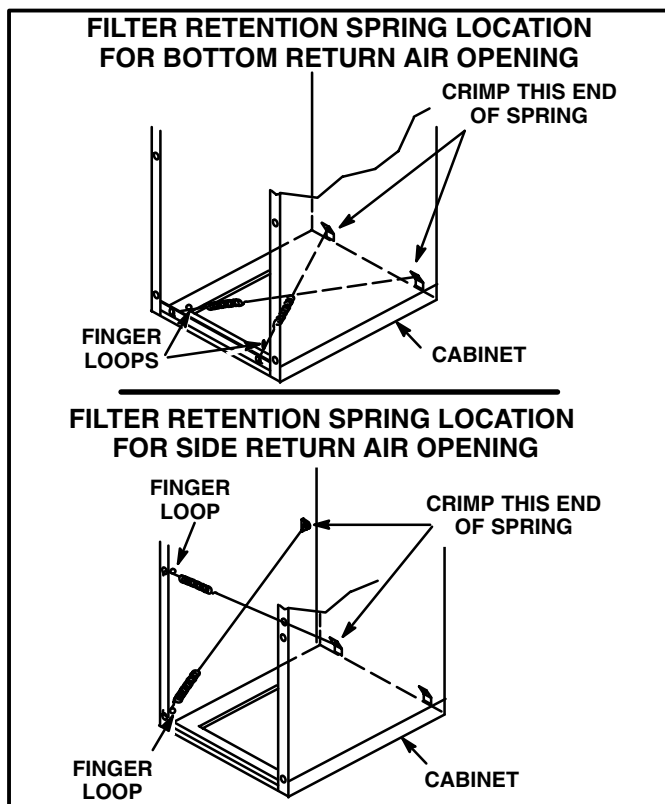

FIGURE 12

B-Filters

- 1- The filter supplied with the G20 series unit can be washed with cold water. Direct water through filters in the opposite direction of air flow. When dry, replace filter and reconnect springs. Refer to figure 12 for spring position.
- 2- Filters must be cleaned or replaced when dirty to assure proper unit operation. Replace with same hogsh-air-type filter material cut to specific measurements for each unit as outlined in the specification table in this manual.

C-Electrical

- 1- Check all wiring for loose connections.
- 2- Check for correct voltage.
- 3- Check amp-draw on blower motor.

V-TYPICAL OPERATING CHARACTERISTICS

A-Temperature Rise

Temperature rise for G20 units depends on unit input, blower speed, blower horsepower and static pressure as marked on the unit rating plate. The blower speed must be set for unit operation within the range of "AIR TEMP. RISE °F" listed on the unit rating plate.

To Measure Temperature Rise:

- 1- Place plenum thermometers in the supply and return air plenums. Locate thermometers in the first horizontal run of the warm air plenum where it will not pick up radiant heat from the heat exchanger.
- 2- Set thermostat to highest setting.
- 3- After plenum thermometers have reached their highest and steadiest readings, subtract the two readings. The difference should be in the range listed on the unit rating plate. If the temperature is too low, decrease blower speed. If temperature is too high, first check the firing rate. Provided the firing rate is acceptable, increase blower speed to reduce temperature. To change blower speed taps see the Blower Speed Taps section in this manual.

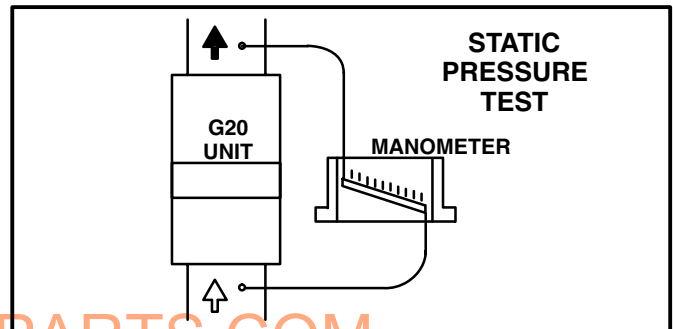

FIGURE 13

To Measure Discharge Static Pressure:

- 1- Measure tap locations as shown in figure 13.
- 2- Punch a 1/4" diameter hole in supply and return air plenums. Insert manometer hose flush with inside edge of hole or insulation. Seal around the hose with permagum. Connect the zero end of the manometer to the discharge (supply) side of the system. On ducted systems, connect the other end of manometer to the return duct as above. For systems with non-ducted returns, leave the other end of the manometer open to the atmosphere.
- 3- With only the blower motor running and the evaporator coil dry, observe the manometer reading. Adjust blower motor speed to deliver the air desired according to the job requirements.
- 4- Seal around the hole when the check is complete.

B-Manifold Pressure

Checks of manifold pressure are made as verification of proper regulator adjustment. Manifold pressure for the G20 can be measured at any time the gas valve is open and is supplying gas to the unit. Normal manifold pressure for natural gas units is 3.5 in. w.c. For LP/propane gas the correct manifold pressure is 9.5 in. w.c.

High Altitude Derate

G20 series units are certified for installations from 0 to 4000 feet (0 to 1219m) above sea level without modification. For installations from 4000 feet to 7500 feet (1219 to 2286m) above sea level, a high altitude kit (44H56) must be installed. The kit contains special flue baffles used to replace factory-installed baffles. No derate is required.

To Measure Manifold Pressure:

CAUTION-For safety, connect a shut-off valve between the manometer and the gas tap to permit shut off of gas pressure to the manometer.

- 1- Connect a test gauge to the outlet pressure tap on the gas valve. Start the unit and allow five minutes for the unit to reach steady state.
- 2- While waiting for the unit to stabilize, notice the flame. The flame should be stable without flashback and should not lift from the burner head. Natural gas should burn blue. L.P. gas should burn mostly blue with some orange streaks.
- 3- After allowing the unit to stabilize for five minutes, record the manifold pressure and compare to the values given above.

CAUTION-Shut unit off and remove manometer as soon as an accurate reading has been obtained. Take care to replace pressure tap plug.

C-Line Pressure

Check gas line pressure with unit firing at maximum rate. A minimum of 4.5 in. w.c. for natural gas or 10.5 in. w.c. for LP/propane gas should be maintained.

D-Flame Signal

A 50 microamp DC meter is needed to check the flame signal on the primary ignition control.

Flame signal or microamp is an electrical current which passes from the ignition control through the sensor electrode during unit operation. The current passes from the sensor through the flame to ground to complete a safety circuit.

To Measure Flame Signal:

- 1- Place the meter in series between the ignition control and sensor wire. Connect the positive (+) lead of the meter to the ignition control sensor connection and the negative (-) lead of the meter to the sensor wire. See figure 14.
- 2- Set thermostat for a heating demand and check the flame signal with the unit operating. For the G20E series, a microamp reading of 1 to 5 microamps DC should occur.

The flame signal may rise above 1 to 5 microamps for the first few seconds after ignition and then level off within the range.

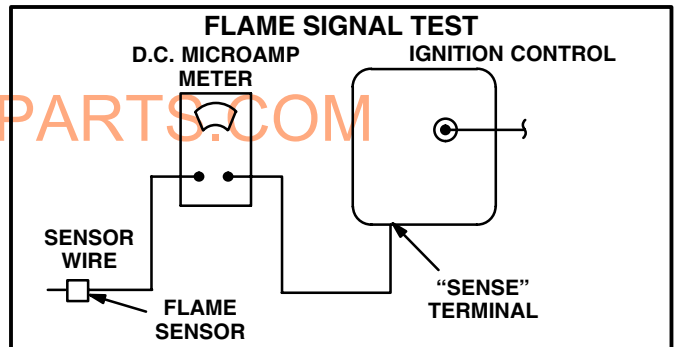
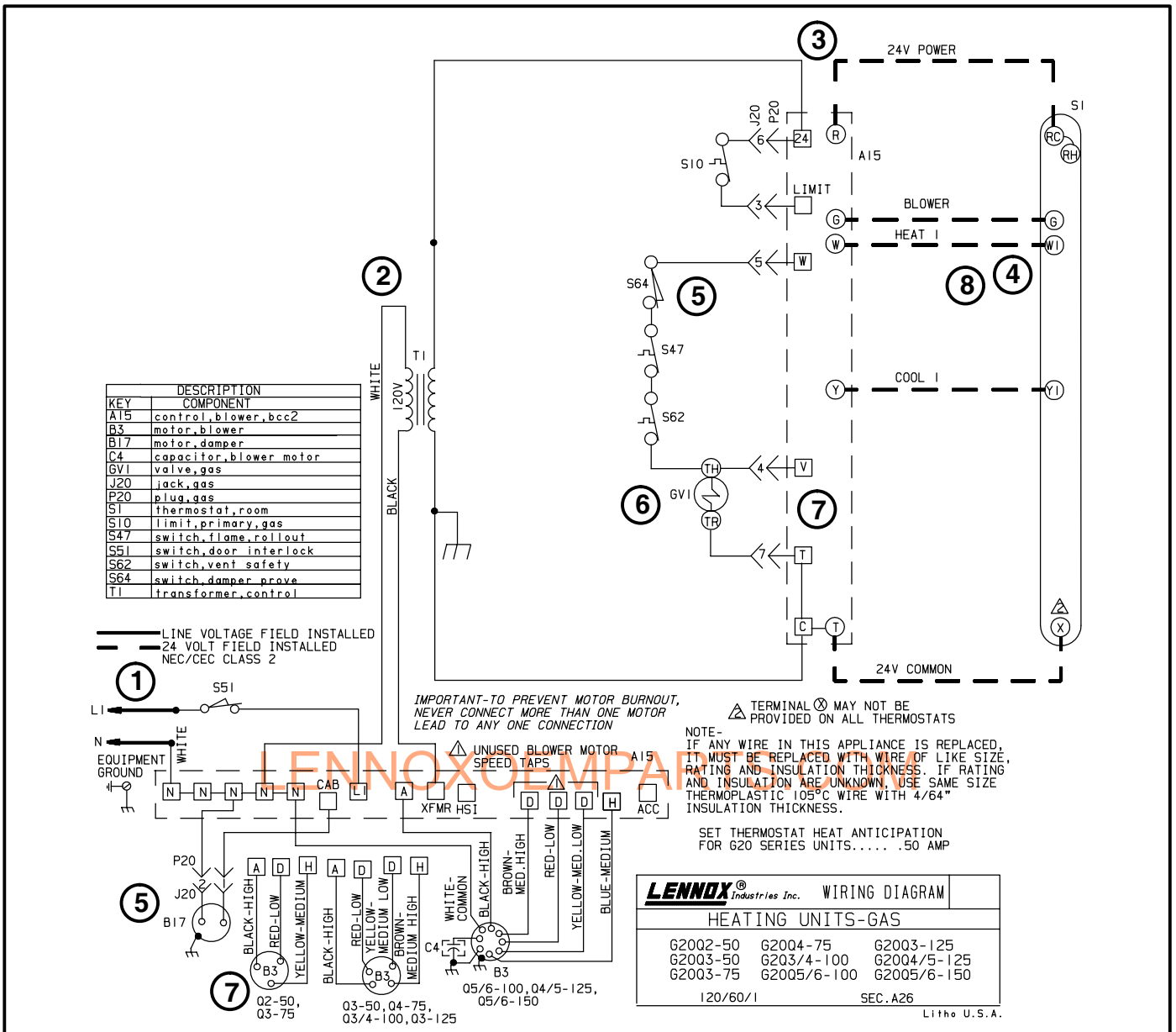
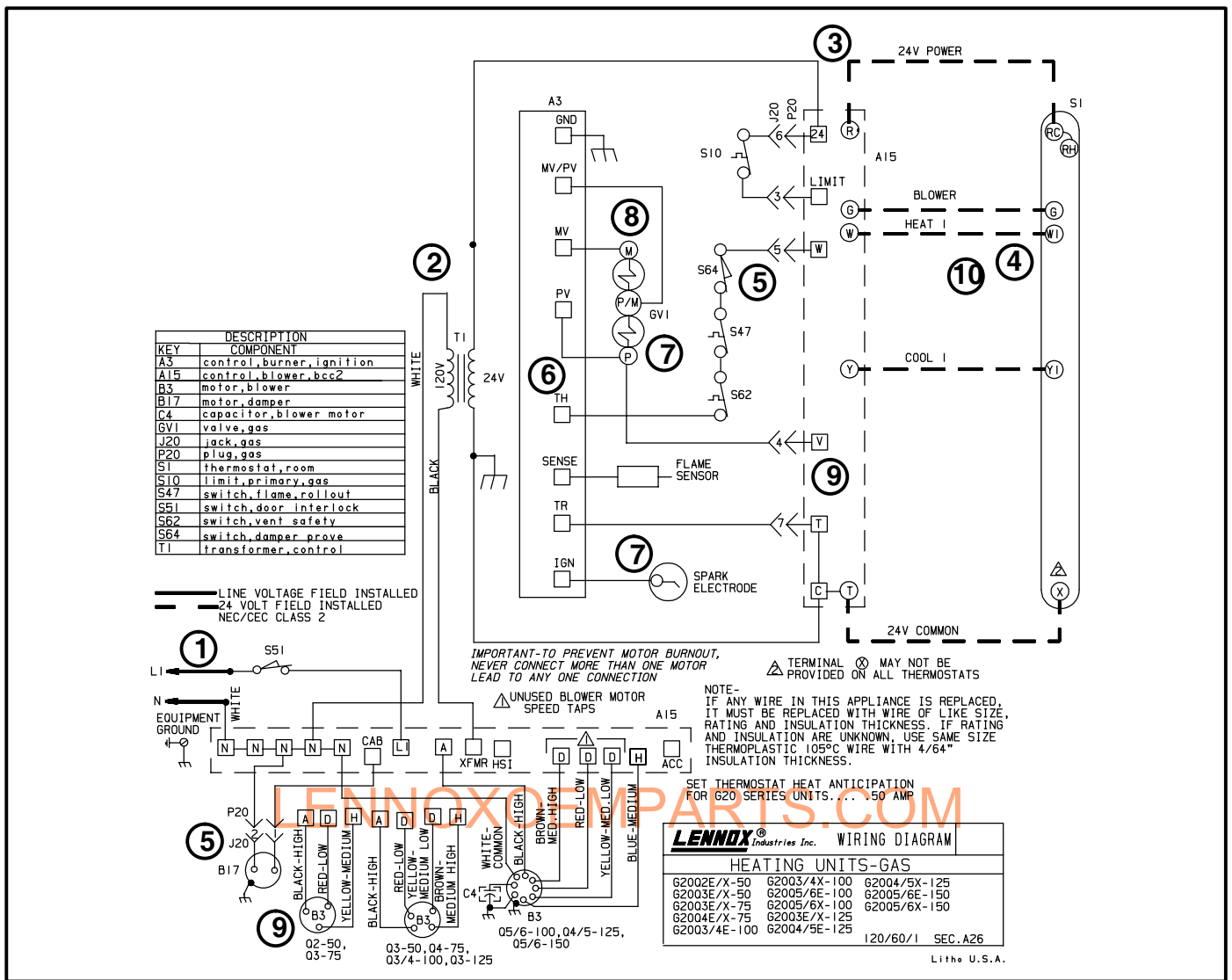

FIGURE 14



OPERATION SEQUENCE- G20 SERIES UNIT

- When disconnect is closed, 120V feeds to line voltage side of the blower control (A15). Door interlock switch (S51) must be closed for A15 to receive voltage.
- A15 supplies 120V to transformer (T1).
- T1 supplies 24VAC to terminal "24" on A15. In turn, terminal "R" of A15 supplies 24VAC to terminal "RC" of the thermostat (S1).
- When there is a call for heat, "W1" of the thermostat energizes "W" of the blower control with 24VAC.
- CAB of the blower control energizes the damper motor (B17) which opens the damper door. When door is in full open position, damper prove switch (S64) closes.
- When S64 closes, assuming the flame rollout switch (S47) and vent safety switch (S62) are closed, 24VAC is supplied to the gas valve (GV1) from terminal "W" of A15.
- Terminal "V"(Valve Sense) of the blower control senses that the gas valve is energized and initiates a 45 second time delay. At the end of the 45 seconds the blower, B3, is energized.
- When the heat demand has been satisfied, W1 of the thermostat de-energizes CAB and gas valve. As the damper closes, the damper spring opens the damper prove switch. The blower runs for a designated period (90-330 sec.) as set by jumper on blower control.



OPERATION SEQUENCE- G20E SERIES (ELECTRONIC CONTROL)

- When disconnect is closed, 120V feeds to line voltage side of the blower control (A15). Door interlock switch (S51) must be closed for A15 to receive voltage.
- A15 supplies 120V to transformer (T1).
- T1 supplies 24VAC to terminal "24" on A15. In turn, terminal "R" of A15 supplies 24VAC to terminal "RC" of the thermostat (S1).
- When there is a call for heat, W1 of the thermostat energizes W of the blower control with 24VAC.
- CAB of the blower control energizes the damper motor (B17) which opens the damper door. When door is in full open position, damper prove switch (S64) closes.
- When S64 closes, assuming the flame rollout switch (S47) and vent safety switch (S62) are closed, 24VAC is supplied to the "TH" terminal of the electronic control (A3).
- Through the electronic control, the pilot valve "P" of the gas valve opens. The spark electrode ignites the pilot and the flame sensor senses the pilot.
- When flame is sensed the main gas valve opens and supplies the burners with gas.
- Terminal "V" (Valve Sense) of the blower control senses that the gas valve is energized and initiates a 45 second time delay. At the end of the 45 seconds the blower, (B3) is energized.
- When the heat demand has been satisfied, W1 of the thermostat de-energizes the gas valve and damper spring closes the damper door. As the damper door closes, the damper prove switch opens. The blower runs for a designated period (90-330 sec.) as set by jumper on blower control.

BCC TROUBLESHOOTING FLOWCHART

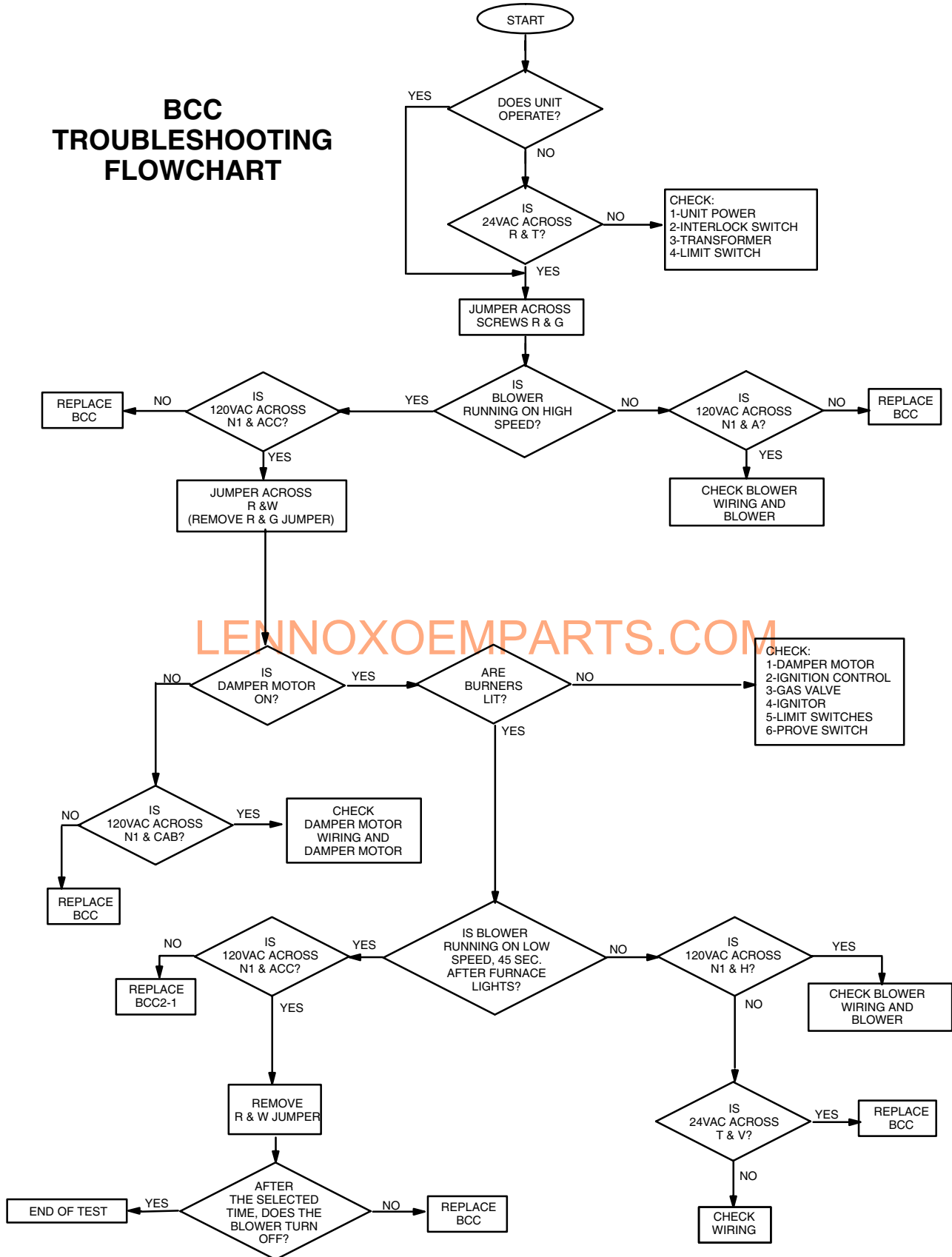

FIGURE 15