

13ACC SERIES UNITS

The 13ACC is a residential split-system condensing unit with SEER ratings up to 14.80. The series is designed for use with expansion valves (TXV) and RFC. All 13ACC units utilize scroll compressors.

13ACC condensing units are available in 2, 2 -1/2, 3, 3 -1/2, 4 and 5 ton capacities. All major components (indoor blower and coil) must be matched according to Lennox recommendations for the compressor to be covered under warranty. Refer to the Engineering Handbook for approved system matchups.

Information contained in this manual is intended for use by qualified service technicians only. All specifications are subject to change.

This manual is divided into sections which discuss the major components, refrigerant system, charging procedure, maintenance and operation sequence.

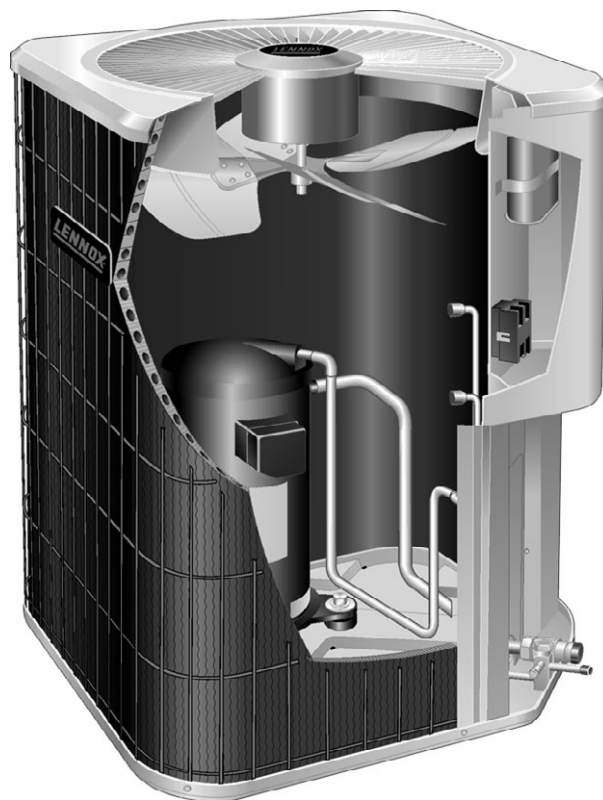

⚠ WARNING

Improper installation, adjustment, alteration, service or maintenance can cause property damage, personal injury or loss of life. Installation and service must be performed by a qualified installer or service agency.

⚠ WARNING

Refrigerant can be harmful if it is inhaled. Refrigerant must be used and recovered responsibly. Failure to follow this warning may result in personal injury or death.

**ELECTROSTATIC DISCHARGE (ESD)
Precautions and Procedures**

⚠ CAUTION

Electrostatic discharge can affect electronic components. Take precautions during unit installation and service to protect the unit's electronic controls. Precautions will help to avoid control exposure to electrostatic discharge by putting the unit, the control and the technician at the same electrostatic potential. Neutralize electrostatic charge by touching hand and all tools on an unpainted unit surface before performing any service procedure.

TABLE OF CONTENTS

General	1
Specifications	2
Electrical Data	3
I Unit Components	3
II Refrigerant System	6
III Charging	7
IV Maintenance	9
V Wiring and Operating Sequence	12

SPECIFICATIONS

Cooling Data		Model No.	13ACC-024	13ACC-030	13ACC-036	13ACC-037
Nominal Size - Tons (kW)			2 (7.0)	2.5 (8.8)	3 (10.6)	3 (10.6)
Connections (sweat)		Liquid line o.d. - in. (mm)	3/8 (9.5)	3/8 (9.5)	3/8 (9.5)	3/8 (9.5)
		Suction line o.d. - in. (mm)	3/4 (19.1)	3/4 (19.1)	7/8 (22.2)	7/8 (22.2)
Condenser Coil	Net face area	Outer coil	15.21 (1.41)	15.21 (1.41)	15.21 (1.41)	19.83 (1.84)
	- sq. ft. (m ²)	Inner coil	5.44 (0.51)	14.50 (1.35)	14.50 (1.35)	18.90 (1.76)
	Tube diameter - in. (mm) & number of rows		5/16 (8) - 1.37	5/16 (8) - 2	5/16 (8) - 2	5/16 (8) - 2
		Fins per inch (m)	22 (866)	22 (866)	22 (866)	22 (866)
**Refrigerant (HCFC-22) furnished			5 lbs. 4 oz. (2.38 kg)	6 lbs. 13 oz. (3.09 kg)	7 lbs. 6 oz. (3.35 kg)	9 lbs. 3 oz. (4.17 kg)
Condenser Fan	Diameter - in. (mm) & Number of blades		18 (457) - 3	18 (457) - 4	18 (457) - 4	18 (457) - 4
	Motor output - hp (W)		1/6 (124)	1/6 (124)	1/6 (124)	1/6 (124)
	Cfm (L/s)		2500 (1180)	2450 (1155)	2450 (1155)	2410 (1135)
	Rpm		1100	1100	1100	1100
	Watts		200	200	200	180
Shipping Data		lbs. (kg) 1 package	155 (70)	175 (79)	180 (82)	191 (87)
Optional Accessories – MUST BE ORDERED EXTRA						
Compressor Crankcase Heater			18K20	18K20	18K20	18K20
Compressor Monitor (Canada Only)			45F08	45F08	45F08	45F08
Hail Guard			17L73	17L73	17L73	
Low Ambient Kit (LB-57113BC)			24H77	24H77	24H77	24H77
Plastic Mounting Base	Model Number - Catalog Number		MB2-S - 69J06	MB2-S - 69J06	MB2-S - 69J06	MB2-S - 69J06
	Dimensions - W x D x H - in. mm		22-1/4 x 22-1/4 x 3 565 x 565 x 76	22-1/4 x 22-1/4 x 3 565 x 565 x 76	22-1/4 x 22-1/4 x 3 565 x 565 x 76	22-1/4 x 22-1/4 x 3 565 x 565 x 76
	Shipping Weight		6 lbs. (3 kg)	6 lbs. (3 kg)	6 lbs. (3 kg)	6 lbs. (3 kg)
Refrigerant Line Set	20 ft. (6 m) length		L15-41-20	L15-41-20	Not Available	Not Available
	30 ft. (9.1 m) length		L15-41-30	L15-41-30	L15-65-30	L15-65-30
	40 ft. (12.2 m) length		L15-41-40	L15-41-40	L15-65-40	L15-65-40
	50 ft. (15.2 m) length		L15-41-50	L15-41-50	L15-65-50	L15-65-50
	Suction Line o.d. - in. (mm)		3/4 (19)	3/4 (19)	7/8 (22.2)	7/8 (22.2)
	Liquid Line o.d. - in. (mm)		3/8 (9.5)	3/8 (9.5)	3/8 (9.5)	3/8 (9.5)
Timed-Off Control (LB-50709BK)			47J27	47J27	47J27	47J27
Unit Stand-Off Kit			94J45	94J45	94J45	94J45

*Refrigerant charge sufficient for 20 ft. (6.1 m) length of refrigerant lines.

Cooling Data		Model No.	13ACC-042	13ACC-047	13ACC-048	13ACC-060
Nominal Size - Tons (kW)			3.5 (12.3)	4 (14.1)	4 (14.1)	5 (17.6)
Connections (sweat)		Liquid line o.d. - in. (mm)	3/8 (9.5)	3/8 (9.5)	3/8 (9.5)	3/8 (9.5)
		Suction line o.d. - in. (mm)	7/8 (22.2)	1-1/8 (28.6)	7/8 (22.2)	1-1/8 (28.6)
Condenser Coil	Net face area	Outer coil	15.21 (1.41)	24.5 (2.28)	21.11 (1.96)	21.11 (1.96)
	- sq. ft. (m ²)	Inner coil	14.50 (1.35)	23.56 (2.19)	20.31 (1.89)	20.31 (1.89)
	Tube diameter - in. (mm) & number of rows		5/16 (8) - 2	5/16 (8) - 2	5/16 (8) - 2	5/16 (8) - 2
		Fins per inch (m)	22 (866)	22 (866)	22 (866)	22 (866)
**Refrigerant (HCFC-22) furnished			7 lbs. 14 oz. (3.57 kg)	11 lbs. 1 oz. (5.02 kg)	10 lbs. 1 oz. (4.56 kg)	10 lbs. 11 oz. (4.85 kg)
Condenser Fan	Diameter - in. (mm) & Number of blades		18 (457) - 4	22 (559) - 4	22 (559) - 4	22 (559) - 4
	Motor output - hp (W)		1/3 (249)	1/4 (186)	1/3 (249)	1/3 (249)
	Cfm (L/s)		2930 (1385)	3830 (1805)	3890 (1835)	3890 (1835)
	Rpm		1100	825	1085	1085
	Watts		310	330	375	375
Shipping Data		lbs. (kg) 1 package	186 (84)	226 (103)	250 (113)	254 (115)
Optional Accessories – MUST BE ORDERED EXTRA						
Compressor Crankcase Heater			18K20	18K20	18K20	18K20
Compressor Monitor (Canada Only)			45F08	45F08	45F08	45F08
Hail Guard			17L73		17L74	17L74
Low Ambient Kit (LB-57113BC)			24H77	24H77	24H77	24H77
Plastic Mounting Base	Model Number - Catalog Number		MB2-S - 69J06	MB2-L - 69J07	MB2-L - 69J07	MB2-L - 69J07
	Dimensions - W x D x H - in. mm		22-1/4 x 22-1/4 x 3 565 x 565 x 76	32 x 34 x 3 813 x 864 x 76	32 x 34 x 3 813 x 864 x 76	32 x 34 x 3 813 x 864 x 76
	Shipping Weight		6 lbs. (3 kg)	15 lbs. (7 kg)	15 lbs. (7 kg)	15 lbs. (7 kg)
Refrigerant Line Set	20 ft. (6 m) length		Not Available	Field Fabricate	Not Available	Field Fabricate
	30 ft. (9.1 m) length		L15-65-30	Field Fabricate	L15-65-30	Field Fabricate
	40 ft. (12.2 m) length		L15-65-40	Field Fabricate	L15-65-40	Field Fabricate
	50 ft. (15.2 m) length		L15-65-50	Field Fabricate	L15-65-50	Field Fabricate
	Suction Line o.d. - in. (mm)		7/8 (22.2)	1-1/8 (28.5)	7/8 (22.2)	1-1/8 (28.5)
	Liquid Line o.d. - in. (mm)		3/8 (9.5)	3/8 (9.5)	3/8 (9.5)	3/8 (9.5)
Timed-Off Control (LB-50709BK)			47J27	47J27	47J27	47J27
Unit Stand-Off Kit			94J45	94J45	94J45	94J45

*Refrigerant charge sufficient for 20 ft. (6.1 m) length of refrigerant lines.

Torque requirements

Part	Recommended Torque	
Service Valve Cap	8 ft. - lb	11 NM
Sheet metal screws	16 in. - lb.	2 NM
Machine screws #10	28 in. - lb.	3 NM
Compressor bolts	90 in. - lb.	10 NM
Gauge port seal cap	8 ft. - lb.	11 NM

ELECTRICAL DATA

General Data	Model No.	13ACC-024	13ACC-030	13ACC-036	13ACC-037	13ACC-042	13ACC-047	13ACC-048	13ACC-060
		-230	-230	-230	-230	-230	-230	-230	-230
Line voltage data - 60 hz		208/230v - 1ph	208/230v - 1ph	208/230v - 1ph	208/230v - 1ph	208/230v - 1ph	208/230v - 1ph	208/230v - 1ph	208/230v - 1ph
Rec. Max. fuse size (amps)		20	30	35	30	35	40	50	60
① Minimum circuit ampacity		14.0	18.0	20.4	19.5	22.5	24.6	31.5	38.0
Compressor	Rated load amps	10.3	13.5	15.4	14.7	16.5	18.3	23.7	28.9
	Power factor	.96	.96	.96	.98	.98	.94	.96	.96
	Locked rotor amps	56.0	72.5	88.0	83.0	95.0	109.0	129.0	169.0
Outdoor Coil Fan Motor	Full load amps	1.1	1.1	1.1	1.1	1.9	1.7	1.9	1.9
	Locked rotor amps	1.9	1.9	1.9	1.9	4.1	3.1	4.1	4.1

*Refer to National or Canadian Electrical Code manual to determine wire, fuse and disconnect size requirements.
NOTE — Extremes of operating range are plus 10% and minus 5% of line voltage.

I - UNIT COMPONENTS

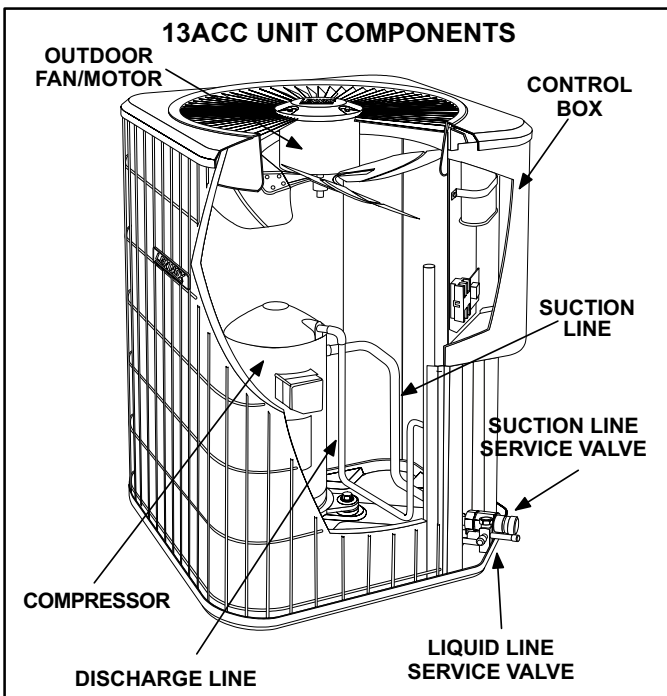

FIGURE 1

A - Control Box (Figure 2)

13ACC units are not equipped with a 24V transformer. All 24 VAC controls are powered by the indoor unit. Refer to wiring diagram.

Electrical openings are provided under the control box cover. Field thermostat wiring is made to color-coded pigtail connections.

1 - Compressor Contactor K1

The compressor is energized by a contactor located in the control box. See figure 2. Single-pole contactors are used in 13ACC series units. K1 is energized by the indoor thermostat terminal Y1 (24V) when thermostat demand is present.

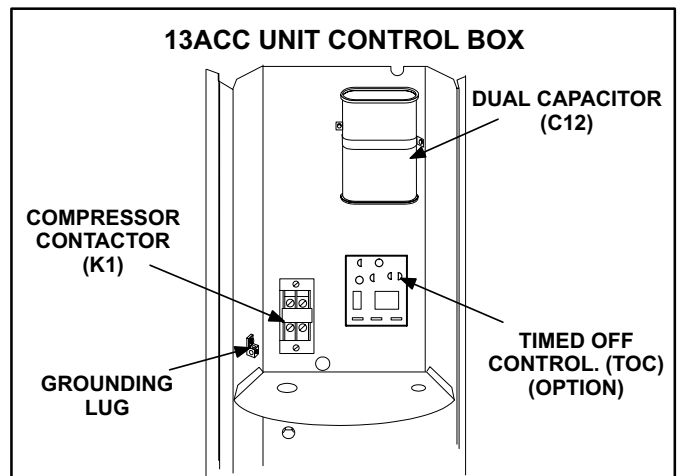

FIGURE 2

⚠ DANGER



13ACC units use single-pole contactors. One leg of compressor, capacitor and condenser fan are connected to line voltage at all times. Potential exists for electrical shock resulting in injury or death. Remove all power at disconnect before servicing.
Can cause personal injury or death.

2 - Dual Capacitor C12

The compressor and fan in 13ACC series units use permanent split capacitor motors. The capacitor is located inside the unit control box (see figure 2). A single "dual" capacitor (C12) is used for both the fan motor and the compressor (see unit wiring diagram). The fan side and the compressor side of the capacitor have different MFD ratings. Ratings will be on compressor nameplate and condenser fan nameplate.

3 - Timed Off Control TOC (option)

The time delay is electrically connected between thermostat terminal Y and the compressor contactor. Between cycles, the compressor contactor is delayed for 5 minutes \pm 2 minutes but may last as long as 8 minutes. At the end of the delay, the compressor is allowed to energize. When thermostat demand is satisfied, the time delay opens the circuit to the compressor contactor coil and the compressor is de-energized.

Without the time delay it would be possible to short cycle the compressor. A scroll compressor, when short cycled, can run backward if head pressure is still high. It does not harm a scroll compressor to run backward, but it could cause a nuisance tripout of safety limits (internal overload). For this reason, if a TOC delay should fail, it must be replaced. Do not bypass the control.

B - Compressor

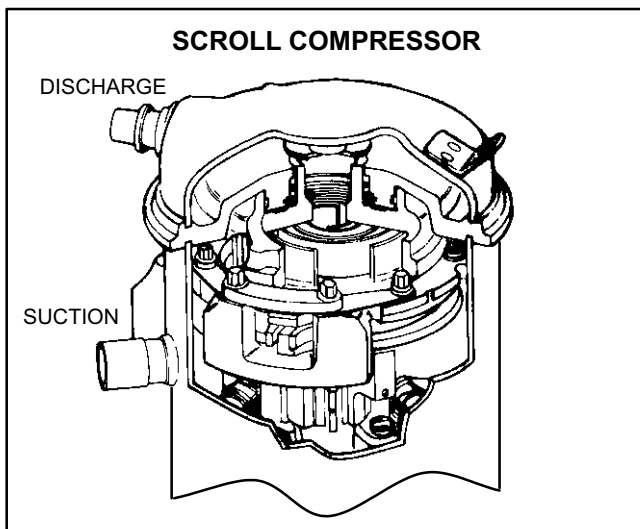

FIGURE 3

All 13ACC units utilize a scroll compressor. The scroll compressor design is simple, efficient and requires few moving parts. A cutaway diagram of the scroll compressor is shown in figure 3. The scrolls are located in the top of the compressor can and the motor is located just below. The oil level is immediately below the motor.

The scroll is a simple compression concept centered around the unique spiral shape of the scroll and its inherent properties. Figure 4 shows the basic scroll form. Two identical scrolls are mated together forming concentric spiral shapes (figure 5). One scroll remains stationary, while the other is allowed to "orbit" (figure 6). Note that the orbiting scroll does not rotate or turn but merely orbits the stationary scroll.

NOTE - During operation, the head of a scroll compressor may be hot since it is in constant contact with discharge gas.

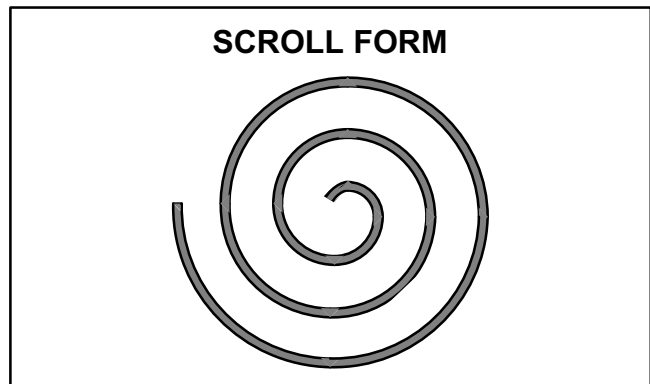

FIGURE 4

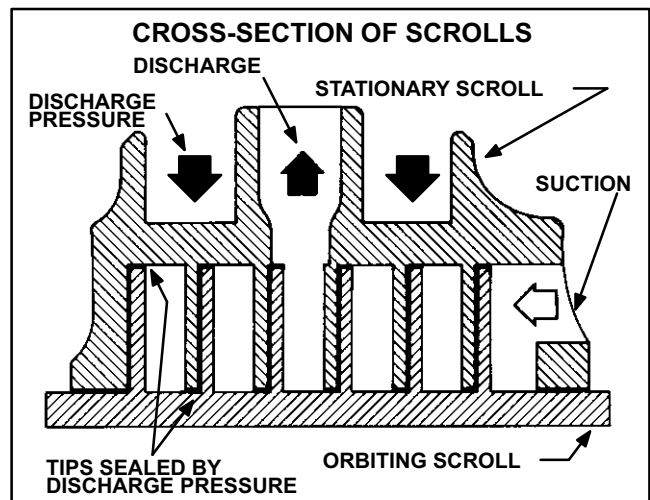

FIGURE 5

The counterclockwise orbiting scroll draws gas into the outer crescent shaped gas pocket created by the two scrolls (figure 6 - 1). The centrifugal action of the orbiting scroll seals off the flanks of the scrolls (figure 6 - 2). As the orbiting motion continues, the gas is forced toward the center of the scroll and the gas pocket becomes compressed (figure 6 - 3). When the compressed gas reaches the center, it is discharged vertically into a chamber and discharge port in the top of the compressor (figure 5). The discharge pressure forcing down on the top scroll helps seal off the upper and lower edges (tips) of the scrolls (figure 5). During a single orbit, several pockets of gas are compressed simultaneously providing smooth continuous compression.

The scroll compressor is tolerant to the effects of liquid return. If liquid enters the scrolls, the orbiting scroll is allowed to separate from the stationary scroll. The liquid is worked toward the center of the scroll and is discharged. If the compressor is replaced, conventional Lennox cleanup practices must be used.

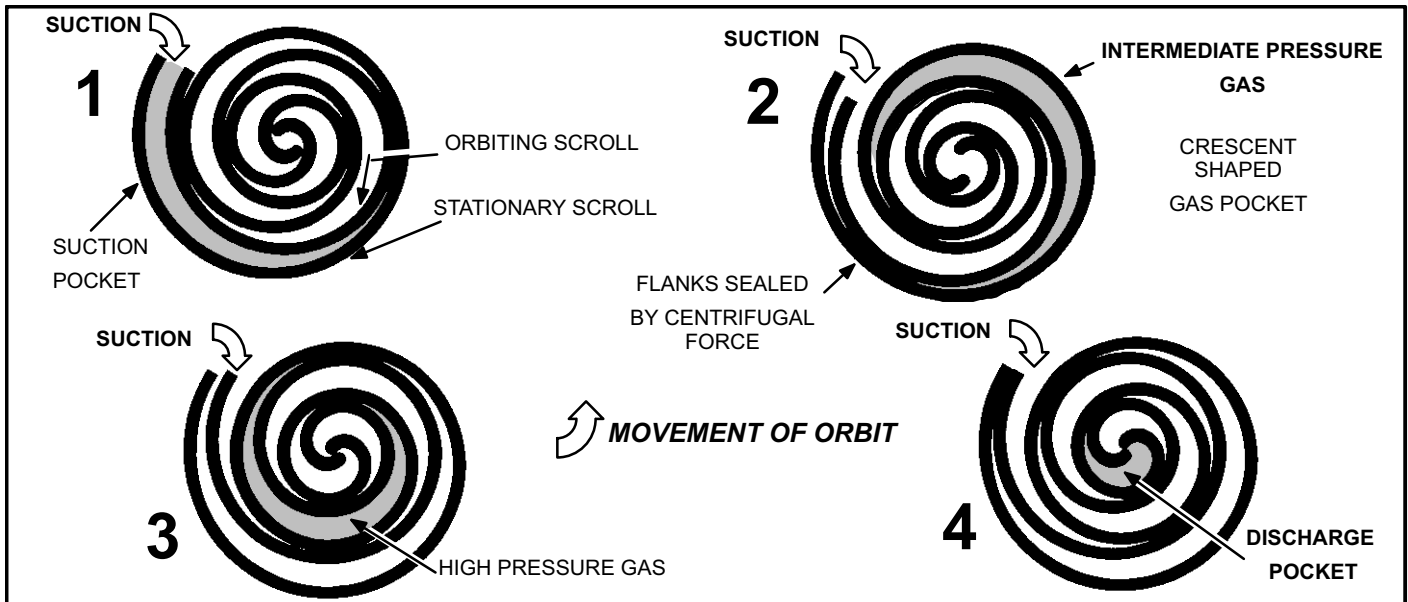

FIGURE 6

Due to its efficiency, the scroll compressor is capable of drawing a much deeper vacuum than reciprocating compressors. Deep vacuum operation can cause internal fuse arcing resulting in damaged internal parts and will result in compressor failure. Never use a scroll compressor for evacuating or to pump system into a vacuum. This type of damage can be detected and will result in denial of warranty claims.

The scroll compressor is quieter than a reciprocating compressor, however, the two compressors have much different sound characteristics. The sounds made by a scroll compressor do not affect system reliability, performance, or indicate damage.

See compressor nameplate or ELECTRICAL DATA for compressor specifications.

C - Condenser Fan Motor

All units use single-phase PSC fan motors which require a run capacitor. In all units, the condenser fan is controlled by the compressor contactor.

ELECTRICAL DATA tables in this manual show specifications for condenser fans used in 13ACCs.

Access to the condenser fan motor on all units is gained by removing the seven screws securing the fan assembly. See figure 7. The condenser fan motor is removed from the fan guard by removing the four nuts found on the top panel. Drip loops should be used in wiring when servicing motor. See figure 8 if condenser fan motor replacement is necessary.

⚠ DANGER

Make sure all power is disconnected before beginning electrical service procedures.

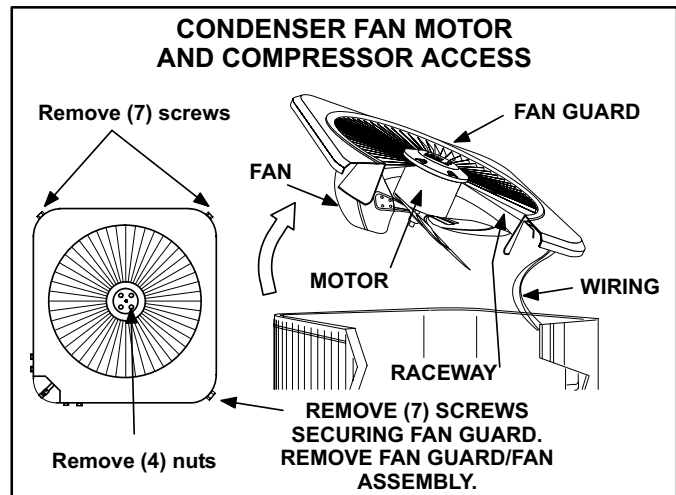

FIGURE 7

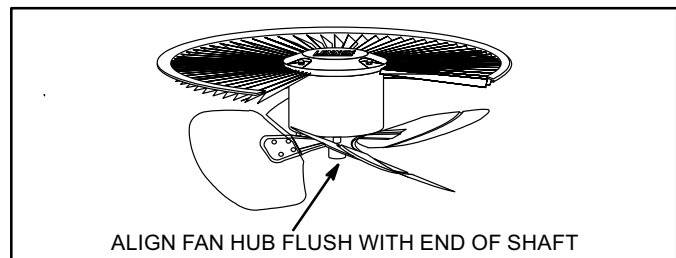

FIGURE 8

II - REFRIGERANT SYSTEM

A - Plumbing

Field refrigerant piping consists of liquid and suction lines from the condensing unit (sweat connections) to the indoor evaporator coil (flare or sweat connections). Use Lennox L15 (sweat) series line sets as shown in table 1.

TABLE 1

Condensing Unit Model No.	Line Set Model No. (L10 or L15)	Length of Lines		Liquid Line Outside Dia.		Suction Line Outside Dia.	
		ft.	m	in.	mm	in.	mm
13ACC024 13ACC030	L15-41-20	20	6	3/8	9.5	3/4	19
	L15-41-30	30	9				
	L15-41-40	40	12				
	L15-41-50	50	15				
13ACC036 13ACC037 13ACC042 13ACC048	L15-65-30	30	9	3/8	9.5	7/8	22.2
	L15-65-40	40	12				
	L15-65-50	50	15				
13ACC047 13ACC060	*Not available			3/8	9.5	1-1/8	28.5

*Field fabricate.

The liquid and suction line service valves (figures 9 and 10) and gauge ports are accessible from outside the unit.

The valve is equipped with a service port. The service ports are used for leak testing, evacuating, charging and checking charge. A schrader valve is factory installed. A service port cap is supplied to protect the schrader valve from contamination and serve as the primary leak seal.

NOTE-Always keep valve stem caps clean.

To Access Schrader Port:

- 1 - Remove service port cap with an adjustable wrench.
- 2 - Connect gauge to the service port.
- 3 - When testing is completed, replace service port cap. Tighten finger tight, then an additional 1/6 turn.

To Open Liquid or Suction Line Service Valve:

- 1 - Remove stem cap with an adjustable wrench.
- 2 - Using service wrench and 5/16" hex head extension back the stem out counterclockwise until the valve stem just touches the retaining ring.
- 3 - Replace stem cap and tighten finger tight, then tighten an additional 1/6 turn.

⚠ DANGER

Do not attempt to backseat this valve. Attempts to backseat this valve will cause snap ring to explode from valve body under pressure of refrigerant. Personal injury and unit damage will result.

To Close Liquid or Suction Line Service Valve:

- 1 - Remove stem cap with an adjustable wrench.
- 2 - Using service wrench and 5/16" hex head extension, turn stem clockwise to seat the valve. Tighten firmly.
- 3 - Replace stem cap. Tighten finger tight, then tighten an additional 1/6 turn.

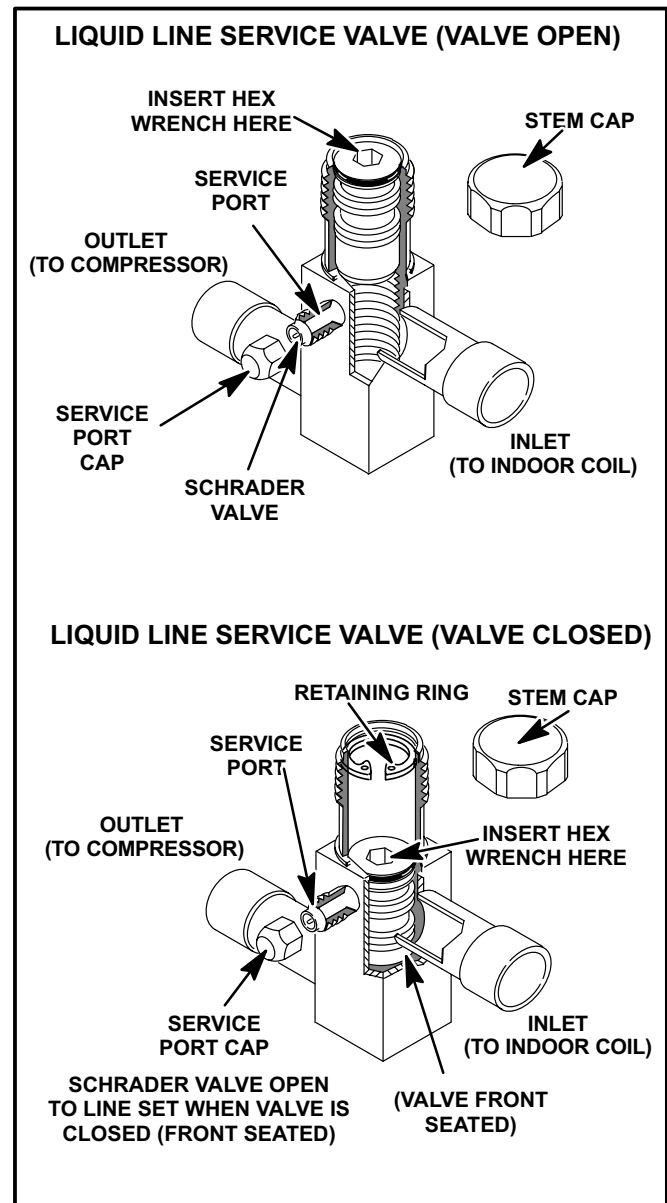

FIGURE 9

B - Service Valves

Suction Line (Ball Type) Service Valve

A ball-type full service valve is used on all 13ACC units. Valves are not rebuildable. If a valve has failed it must be replaced. A ball valve is illustrated in figure 10.

The ball valve is equipped with a service port. A schrader valve is factory installed. A service port cap is supplied to protect the schrader valve from contamination and assure a leak free seal.

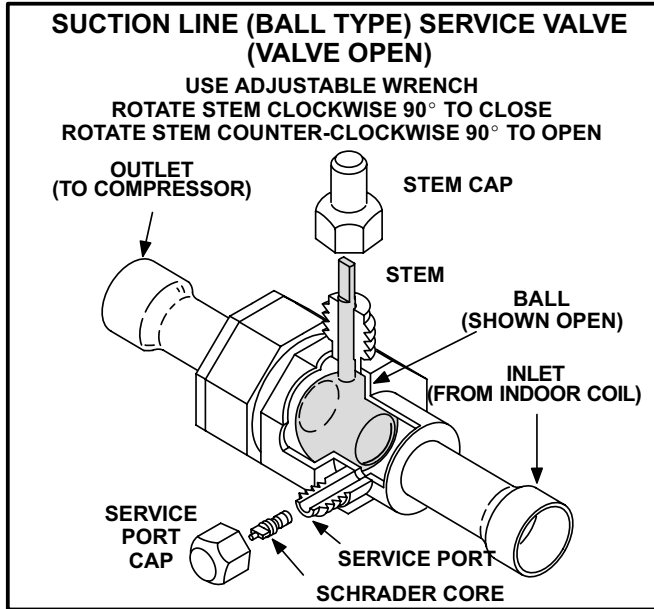

FIGURE 10

III - CHARGING

The unit is factory-charged with the amount of R-22 refrigerant indicated on the unit rating plate. This charge is based on a matching indoor coil and outdoor coil with a 20 foot (6.1 m) line set. For varying lengths of line set, refer to table 2 for refrigerant charge adjustment. A blank space is provided on the unit rating plate to list actual field charge.

! IMPORTANT

If line length is greater than 20 feet (6.1 m) add this amount. If line length is less than 20 feet (6.1 m), subtract this amount.

TABLE 2

LIQUID LINE SET DIAMETER	Ounce per 5 foot (ml per mm) adjust from 20 foot (6.1m) line set*
3/8 in. (10 mm)	3 ounce per 5 feet (90 ml per 1524 mm)

*If line set is greater than 20 ft. (6.1m) add this amount. If line set is less than 20 feet (6.1 m) subtract this amount

Units are designed for line sets up to 50 feet (15.2 m). Consult Lennox Refrigerant Piping Manual for line sets over 50 feet (15.2 m).

A - Pumping Down System

! CAUTION

Deep vacuum operation (operating compressor at 0 psig or lower) can cause internal fusite arcing resulting in a damaged or failed compressor. This type of damage will result in denial of warranty claim.

The system may be pumped down when leak checking the line set and indoor coil or making repairs to the line set or indoor coil.

- 1- Attach gauge manifold.
- 2- Front seat (close) liquid line valve.
- 3- Start outdoor unit.
- 4- Monitor suction gauge. Stop unit when 0 psig is reached.
- 5- Front seat (close) suction line valve.

B - Leak Testing (To Be Done Before Evacuating)

- 1- Attach gauge manifold and connect a drum of dry nitrogen to center port of gauge manifold.
- 2- Open high pressure valve on gauge manifold and pressurize line set and indoor coil to 150 psig (1034 kPa).
- 3- Check lines and connections for leaks.

NOTE-The preferred method is to use an electronic leak or Halide detector. Add a small amount of R22 (3 to 5 psig [20kPa to 34kPa]) then pressurize with nitrogen to 150 psig.

- 4- Release nitrogen pressure from the system, correct any leaks and recheck.

! CAUTION

When using dry nitrogen, a pressure reducing regulator must be used to prevent excessive pressure in gauge manifold, connecting hoses, and within the system. Regulator setting must not exceed 150 psig (1034 kpa). Failure to use a regulator can cause equipment failure resulting in injury.

C - Evacuating the System

- 1- Attach gauge manifold. Connect vacuum pump (with vacuum gauge) to center port of gauge manifold. With both manifold service valves open, start pump and evacuate indoor coil and refrigerant lines.

IMPORTANT

A temperature vacuum gauge, mercury vacuum (U-tube), or thermocouple gauge should be used. The usual Bourdon tube gauges are not accurate enough in the vacuum range.

IMPORTANT

The compressor should never be used to evacuate a refrigeration or air conditioning system.

- 2- Evacuate the system to 29 inches (737mm) vacuum. During the early stages of evacuation, it is desirable to stop the vacuum pump at least once to determine if there is a rapid loss of vacuum. A rapid loss of vacuum would indicate a leak in the system and a repeat of the leak testing section would be necessary.
- 3- After system has been evacuated to 29 inches (737mm), close gauge manifold valves to center port, stop vacuum pump and disconnect from gauge manifold. Attach an upright nitrogen drum to center port of gauge manifold and open drum valve slightly to purge line at manifold. Break vacuum in system with nitrogen pressure by opening manifold high pressure valve. Close manifold high pressure valve to center port.
- 4- Close nitrogen drum valve and disconnect from gauge manifold center port. Release nitrogen pressure from system.
- 5- Connect vacuum pump to gauge manifold center port. Evacuate system through manifold service valves until vacuum in system does not rise above .5mm of mercury absolute pressure or 500 microns within a 20-minute period after stopping vacuum pump.
- 6- After evacuation is complete, close manifold center port, and connect refrigerant drum. Pressurize system slightly with refrigerant to break vacuum.

D - Charging

The condensing unit should be charged during warm weather. However, applications arise in which charging must occur in the colder months. *The method of charging is determined by the unit's refrigerant metering device and the outdoor ambient temperature.*

Measure the liquid line temperature and the outdoor ambient temperature as outlined below:

1. -Connect the manifold gauge set to the service valves: low pressure gauge to suction valve service port; high pressure gauge to liquid valve service port. Connect the center manifold hose to an upright cylinder of HCFC-22. Close manifold gauge set valves.
2. -Set the room thermostat to call for heat. This will create the necessary load for properly charging the system in the cooling cycle.
3. -Use a digital thermometer to record the outdoor ambient temperature.
4. -When the heating demand has been satisfied, switch the thermostat to cooling mode with a set point of 68°F (20°C). When pressures have stabilized, use a digital thermometer to record the liquid line temperature.
5. -The outdoor temperature will determine which charging method to use. Proceed with the appropriate charging procedure.

Weighing in the Charge Fixed Orifice or TXV Systems – Outdoor Temp < 65°F (18°C)

If the system is void of refrigerant, or if the outdoor ambient temperature is cool, the refrigerant charge should be weighed into the unit according to the total amount shown on the unit nameplate. This may be done after any leaks have been repaired. If weighing facilities are not available or if unit is being charged during warm weather, follow one of the other procedures outlined below.

- 1 - Recover the refrigerant from the unit.
- 2 - Conduct a leak check, then evacuate as previously outlined.
- 3 - Weigh in the factory charge according to the amount recorded on the outdoor unit nameplate.

Expansion Valve Systems

Charging Using the Approach Method

TXV Systems - Outdoor Temp. $\geq 65^{\circ}\text{F}$ (18°C)

⚠ IMPORTANT

The following procedure requires accurate readings of ambient (outdoor) temperature, liquid temperature and liquid pressure for proper charging. Use a thermometer with accuracy of $\pm 2^{\circ}\text{F}$ ($\pm 1.1^{\circ}\text{C}$) and a pressure gauge with accuracy of ± 5 PSIG (± 34.5 kPa).

When an expansion valve system is being charged when the outdoor ambient temperature is 65°F (16°C) or above, it is best to charge the unit using the approach method.

Subtract the outdoor ambient temperature from the liquid line temperature to determine the Approach temperature. **(Liquid Line $^{\circ}\text{F}$ ($^{\circ}\text{C}$) - Outdoor Ambient $^{\circ}\text{F}$ ($^{\circ}\text{C}$) = Approach Temperature.)** The resulting difference (Approach temperature) should agree with the values given in table 3. If not, add refrigerant to lower the approach temperature or recover refrigerant from the system to increase the approach temperature.

Table 3
Approach Temperatures
(TXV Systems Only)

Model No.	Approach Temperature Liquid Line - Outdoor Ambient $^{\circ}\text{F}$ ($^{\circ}\text{C}$)
13ACC-024	9 (5) ± 1
13ACC-030	6 (3) ± 1
13ACC-036	10 (6) ± 1
13ACC-037	12 (7) ± 1
13ACC-042	8 (4) ± 1
13ACC-048	7 (4) ± 1
13ACC-047	10 (6) ± 1
13ACC-060	12 (7) ± 1

NOTE - For best results, use the same digital thermometer to check both outdoor ambient and liquid temperatures.

Charging Using the Subcooling Method TXV & Fixed Orifice Systems – Outdoor Temp. $\geq 65^{\circ}\text{F}$ (18°C)

If you charge a fixed orifice system when the outdoor ambient is 65°F (18°C) or above, use the subcooling method to charge the unit.

- 1 - With the manifold gauge hose still on the liquid service port and the unit operating stably, use a digital thermometer to record the liquid line temperature.
- 2 - At the same time, record the liquid line pressure reading.
- 3 - Use a temperature/pressure chart for HCFC-22 to determine the saturation temperature for the liquid line pressure reading.
- 4 - Subtract the liquid line temperature from the saturation temperature (according to the chart) to determine subcooling. **(Saturation temperature - Liquid line temperature = Subcooling)**
- 5 - Compare the subcooling value with those in table 4. If subcooling is greater than shown, some refrigerant must be recovered. If subcooling is less than shown, some refrigerant must be added.

E - Oil Charge

Refer to compressor nameplate.

IV - MAINTENANCE

⚠ DANGER

Make sure all power is disconnected before beginning electrical service procedures.

At the beginning of each cooling season, the system should be cleaned as follows:

A - Outdoor Unit

- 1 - Clean and inspect condenser coil. (Coil may be flushed with a water hose).
- 2 - Visually inspect all connecting lines, joints and coils for evidence of oil leaks.

NOTE-Outdoor fan motors are permanently lubricated.

B - Indoor Coil

- 1 - Clean coil if necessary.
- 2 - Check connecting lines and coil for evidence of oil leaks.
- 3 - Check condensate line and clean if necessary.

C - Indoor Unit

- 1 - Clean or change filters.
- 2 - Bearings are pre-lubricated and need no further oiling.
- 3 - Check all wiring for loose connections.
- 4 - Check for correct voltage at unit.
- 5 - Check amp-draw on blower motor.

Unit nameplate _____ Actual _____.

Table 4
Subcooling (SC) and Superheat (SH)*
 Reading s are in °F

Metering Device	Out. Coil Entering Air°F (°C)	-024		-030		-036		-037		-042		-047		-048		-060	
		SC±2	SH±2	SC±2	SH±2	SC±2	SH±2	SC±2	SH±2	SC±2	SH±2	SC±2	SH±2	SC±2	SH±2	SC±2	SH±2
13ACC TXV	65 (18.3)	9	17	9	13	7	20	8	19	8	18	9	19	11	27	16	21
	70 (21)	9	16	8	14	7	18	8	18	8	18	10	19	10	26	15	20
	75 (23.9)	8	17	8	14	8	18	8	18	8	18	10	18	10	24	14	18
	80 (27)	8	17	8	14	8	17	8	18	9	18	10	17	10	24	13	17
	85 (29.4)	7	17	8	15	8	18	8	17	9	18	10	19	9	23	13	17
	90 (32)	6	18	9	16	8	18	9	16	9	19	9	17	9	23	13	17
	95 (35)	6	18	9	17	8	19	7	16	9	19	9	17	9	23	13	17
	100 (38)	6	19	9	17	8	20	8	16	9	19	9	18	9	23	12	17
	105 (40.6)	7	19	8	17	8	20	9	17	10	19	9	19	9	24	12	18
	110 (43)	6	20	8	17	8	20	8	18	10	19	9	19	8	24	10	18
	115 (45)	6	21	9	17	9	22	8	19	11	20	9	18	7	24	10	17
13ACC RFC	RFC SIZE	0.063 42J4301		0.071 42J4701		0.078 42J5101		0.077 42J5001		0.079 25M5601		0.084 42J5401		0.093 78L7401		0.099 42J6201	
	Out. Coil Entering Air°F (°C)	SC±1	SH±1	SC±1	SH±1	SC±1	SH±1	SC±1	SH±1	SC±1	SH±1	SC±1	SH±1	SC±1	SH±1	SC±1	SH±1
	65 (18.3)	14	25	10	29	12	32	10	32	13	30	8	29	13	36	19	31
	70 (21)	14	24	10	29	11	30	9	29	13	28	8	28	13	33	18	29
	75 (23.9)	13	24	10	28	11	28	10	27	12	26	7	27	13	30	18	27
	80 (27)	12	23	10	25	10	27	9	25	11	24	7	25	13	29	17	25
	85 (29.4)	11	22	9	22	8	25	9	22	10	22	7	24	12	27	16	22
	90 (32)	9	21	8	20	7	22	8	18	9	19	6	22	11	25	15	20
	95 (35)	8	19	7	15	7	19	8	16	8	17	6	20	10	23	14	18
	100 (38)	7	18	6	9	5	14	8	6	8	13	6	17	10	20	13	14
	105 (40.6)	5	16	6	3	4	11	8	2	7	9	5	11	10	15	13	9
	110 (43)	4	13	5	4	3	5	7	1	5	3	5	4	9	11	12	3
115 (45)	4	7	4	2	3	2	6	1	4	2	4	1	8	2	10	2	

* Reading taken at compressor.

Table 5
Normal Operating Pressures In psig (liquid and suction +/- 2 psig)*

Unit / Metering Device	Out. Coil Entering Air Temp. °F (°C)	-024		-030		-036		-037		-042		-047		-048		-060	
		LIQ.	SUC.	LIQ.	SUC.	LIQ.	SUC.	LIQ.	SUC.	LIQ.	SUC.	LIQ.	SUC.	LIQ.	SUC.	LIQ.	SUC.
13ACC TXV	65 (18.3)	145	79	143	73	148	77	157	78	144	77	146	73	151	69	171	75
	70 (21)	158	79	154	74	160	78	170	79	156	78	158	74	163	71	184	77
	75 (23.9)	170	80	167	74	175	79	184	80	170	79	171	74	177	72	197	78
	80 (27)	184	81	181	75	190	79	198	81	185	79	185	75	191	73	211	79
	85 (29.4)	198	82	195	75	205	80	213	81	199	80	200	76	206	74	226	79
	90 (32)	213	82	210	76	221	81	229	82	215	80	215	73	221	75	242	80
	95 (35.0)	229	83	227	76	237	82	242	82	231	81	231	77	237	79	257	80
	100 (38)	245	84	242	77	253	82	263	83	249	81	248	77	254	76	276	81
	105 (40.6)	262	84	259	7	272	82	279	84	266	81	265	78	271	77	294	82
	110 (43)	279	85	277	79	291	83	296	84	284	81	284	79	289	78	312	83
115 (45)	297	86	296	80	310	83	316	85	303	82	303	80	289	78	334	83	
13ACC RFC	65 (18.3)	147	69	140	61	149	68	150	66	147	68	139	59	148	59	169	68
	70 (21)	160	73	152	64	162	71	165	70	159	71	155	62	163	63	183	71
	75 (23.9)	173	76	166	68	176	74	180	74	173	74	166	64	177	66	198	74
	80 (27)	187	78	180	71	190	76	195	77	186	75	177	66	191	68	213	76
	85 (29.4)	201	80	194	73	204	78	210	79	200	77	190	67	206	71	228	78
	90 (32)	216	82	209	75	219	80	226	81	214	79	201	68	223	73	245	80
	95 (35.0)	231	83	224	76	236	81	242	82	231	80	220	70	238	75	261	81
	100 (38)	246	85	241	77	252	82	260	84	247	81	238	71	257	76	279	82
	105 (40.6)	262	86	257	78	270	84	279	85	264	83	256	72	274	77	297	83
	110 (43)	279	86	276	81	288	85	297	86	281	84	271	73	292	79	316	85
115 (45)	298	87	294	82	307	86	313	87	300	85	290	74	309	80	336	86	

*These are typical pressures only. Indoor evaporator match up, indoor air quality, and evaporator load will cause the pressures to vary.

V - WIRING DIAGRAMS AND SEQUENCE OF OPERATION

13ACC 2 THROUGH 5 TON OPERATING SEQUENCE

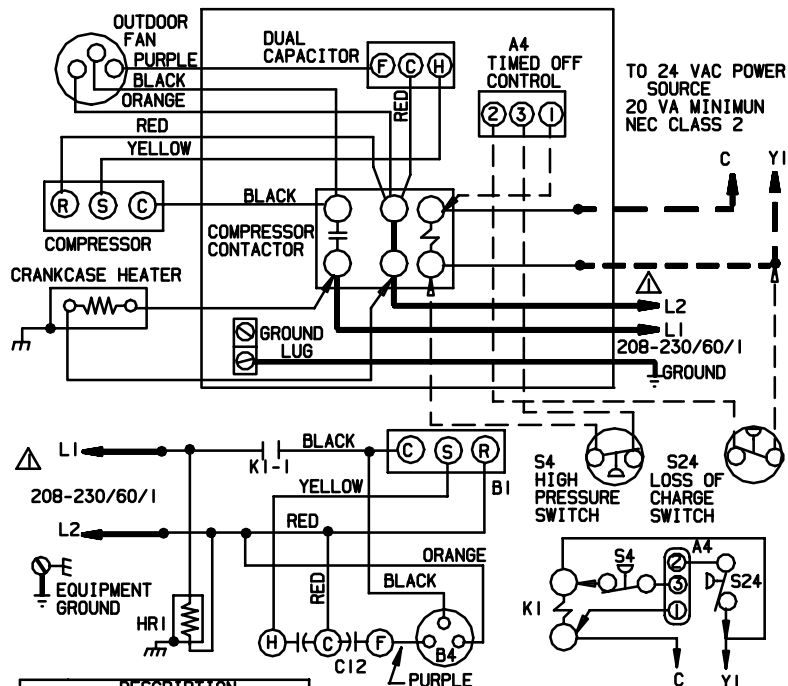

KEY	DESCRIPTION
A4	CONTROL-TIMED OFF
B1	COMPRESSOR
B4	MOTOR-OUTDOOR FAN
C12	CAPACITOR-DUAL
HRI	HEATER-COMPRESSOR
K1-1	CONTACTOR-COMPRESSOR
S4	SWITCH-HIGH PRESURE
S24	SWITCH-LOSS OF CHARGE

FOR USE WITH COPPER CONDUCTORS ONLY. REFER TO UNIT RATING PLATE FOR MINIMUM CIRCUIT AMPACITY AND MAXIMUM OVERCURRENT PROTECTION SIZE.

WARNING- ELECTRIC SHOCK HAZARD, CAN CAUSE INJURY OR DEATH. UNIT MUST BE GROUNDED IN ACCORDANCE WITH NATIONAL AND LOCAL CODES.

← INDICATES OPTIONAL COMPONENTS ——— LINE VOLTAGE FIELD INSTALLED
 - - - - - CLASS 11 VOLTAGE FIELD INSTALLED

LENNOX®	
COOLING UNITS- CONDENSING UNITS	
13ACC-024, 030, 036, 037, 042, 047, 048, 060-230-01	
0502	Supersedes Form No.
	New Form No. 534, 024W

©2002 Lennox Industries Inc.

Litho U.S.A.

NOTE- The thermostat used may be electromechanical or electronic.

NOTE- Transformer in indoor unit supplies power (24 VAC) to the thermostat and outdoor unit controls.

COOLING:

- 1- Cooling demand initiates at Y1 in the thermostat.
- 2- 24VAC from indoor unit (Y1) energizes the timed off control TOC (if used), which energizes compressor contactor K1 provided the 5 minute delay is satisfied.
- 3- K1-1 N.O. closes, energizing compressor (B1) and outdoor fan motor (B4).
- 4 - Compressor (B1) and outdoor fan motor (B4) begin immediate operation..

END OF COOLING DEMAND:

- 5- Cooling demand is satisfied. Terminal Y1 is de-energized.
- 6- Compressor contactor K1 is de-energized.
- 7- K1-1 opens and compressor (B1) and outdoor fan motor (B4) are de-energized and stop immediately.