

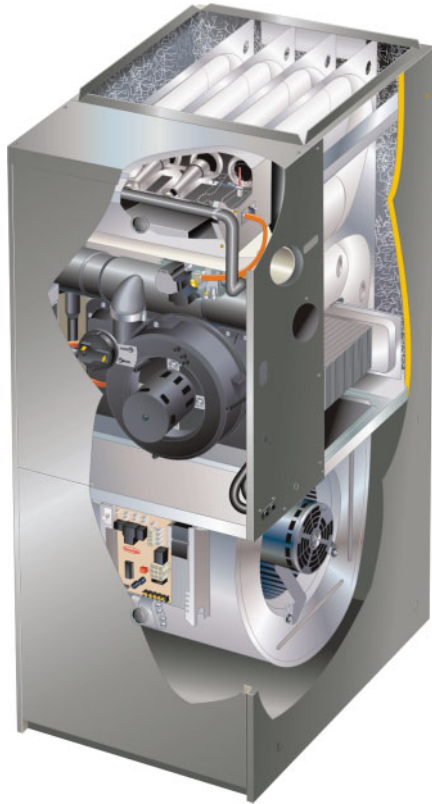

© 2005 Lennox Industries Inc.  
Dallas, Texas, USA

# INSTALLATION INSTRUCTIONS

## G43UF SERIES UNITS



**GAS UNITS**  
505,064M  
05/2009  
Supersedes 07/2007

**TP** Technical  
Publications  
Litho U.S.A.

### Table of Contents

Unit Dimensions . . . . .	2
G43UF Parts Identification . . . . .	3
Shipping and Packing List . . . . .	4
Safety Information . . . . .	4
Use of Furnace as a Construction Heater . . . . .	5
General . . . . .	5
Combustion, Dilution & Ventilation Air . . . . .	6
Installation - Setting Equipment . . . . .	8
Filters . . . . .	11
Duct System . . . . .	11
Pipe & Fittings Specifications . . . . .	12
Vent Piping Guidelines . . . . .	14
Joint Cementing Procedure . . . . .	15
Venting Practices . . . . .	15
Gas Piping . . . . .	25
Electrical . . . . .	28
Unit Start-Up . . . . .	31
Gas Pressure Adjustment . . . . .	33
High Altitude Information . . . . .	34
Other Unit Adjustments . . . . .	36
Service . . . . .	39
Ignition Control Board Diagnostic Codes . . . . .	41
Troubleshooting . . . . .	42
Repair Parts List . . . . .	45
Vent Pipe Sizing Worksheet . . . . .	46
Start-Up & Performance Check List . . . . .	46

**THIS MANUAL MUST BE LEFT WITH THE  
HOMEOWNER FOR FUTURE REFERENCE**



### **⚠ WARNING**

**FIRE OR EXPLOSION HAZARD.**

**Failure to follow safety warnings exactly could result in serious injury, death, or property damage.**



**Do not store or use gasoline or other flammable vapors and liquids in the vicinity of this or any other appliance.**

**Installation and service must be performed by a qualified installer, service agency or the gas supplier.**

### **WHAT TO DO IF YOU SMELL GAS:**

- **Do not try to light any appliance.**
- **Do not touch any electrical switch; do not use any phone in your building.**
- **Leave the building immediately.**
- **Immediately call your gas supplier from a neighbor's phone. Follow the gas supplier's instructions.**
- **If you cannot reach your gas supplier, call the fire department.**



## G43UF Unit Dimensions - inches (mm)

**\*NOTE - 60C and 60D size units installed in upflow applications that require air volumes over 1800 cfm (850 L/s) must have one of the following:**

1. Single side return air with transition, to accommodate 20 x 25 x 1 in. (508 x 635 x 25 mm) air filter. Required to maintain proper air velocity.
2. Single side return air with optional RAB Return Air Base
3. Bottom return air.
4. Return air from both sides.
5. Bottom and one side return air.

Refer to Engineering Handbook for additional information.

**\*\*Consider sizing requirements for optional IAQ equipment before cutting side return opening.**

<sup>1</sup> Optional External Side Return Air Filter Kit is not for use with the optional RAB Return Air Base.

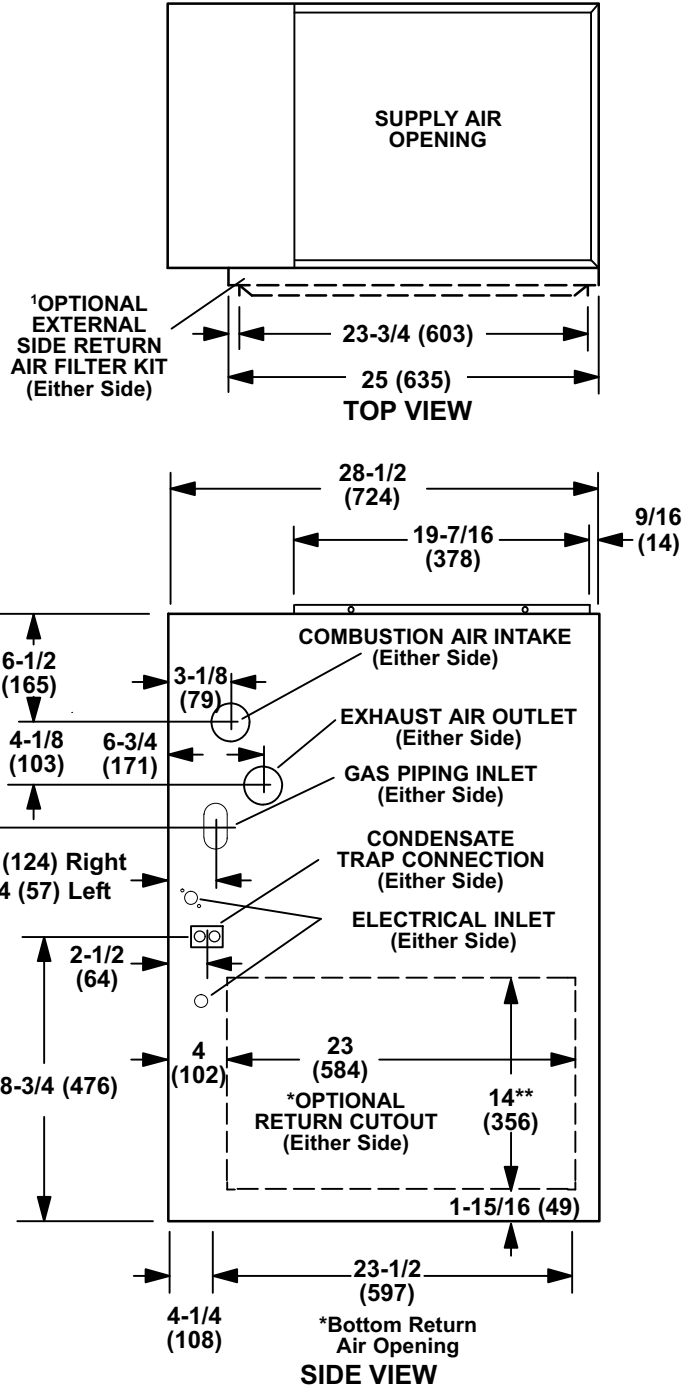

Model No.	A		B		C	
	in.	mm	in.	mm	in.	mm
G43UF-24B-045 G43UF-24B-070 G43UF-36B-070	17-1/2	446	16-3/8	416	16	406
G43UF-36C-090 G43UF-36C-090H G43UF-48C-090 G43UF-48C-110 G43UF-48C-110H G43UF-60C-110	21	533	19-7/8	504	19-1/2	495
G43UF-60D-135	24-1/2	622	23-3/8	546	23	584

G43UF PARTS IDENTIFICATION

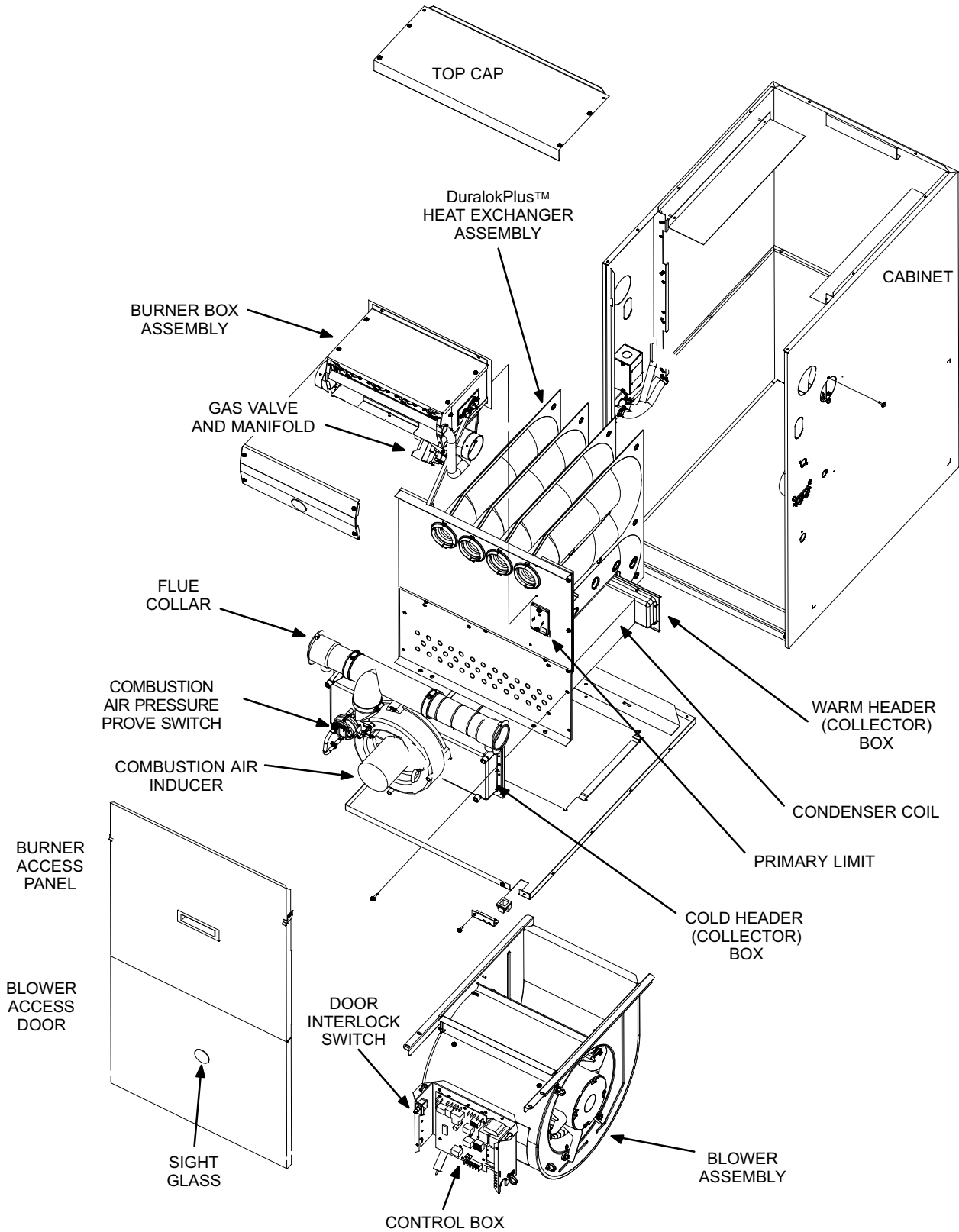

FIGURE 1

## G43UF Gas Furnace

The G43UF Category IV gas furnace is shipped ready for installation in the upflow position. The furnace is shipped with the bottom panel in place. The bottom panel must be removed if the unit is to be installed in upflow applications with bottom return air.

**The G43UF can be installed as either a Direct Vent or a Non-Direct Vent gas central furnace.**

The furnace is equipped for installation in natural gas applications. A conversion kit (ordered separately) is required for use in propane/LP gas applications.

**NOTE** - In Direct Vent installations, combustion air is taken from outdoors and flue gases are discharged outdoors. In Non-Direct Vent installations, combustion air is taken from indoors and flue gases are discharged outdoors. See figure 2 for applications involving roof termination.

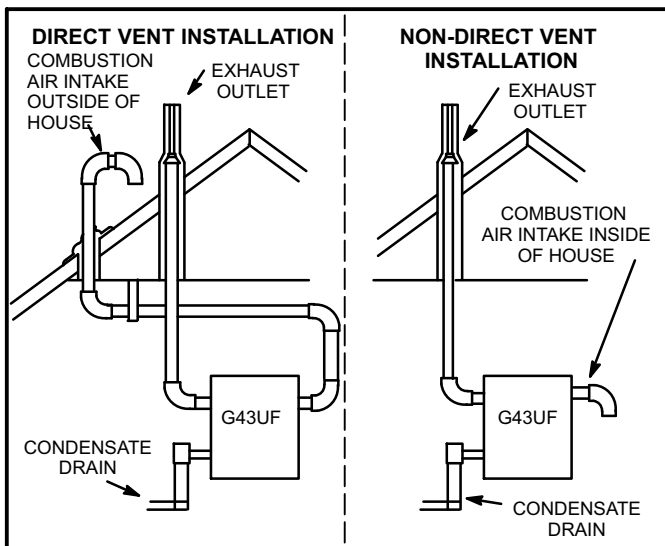

FIGURE 2

## Shipping and Packing List

### Package 1 of 1 contains

- 1 - Assembled G43UF unit
- 1 - Bag assembly containing the following:
  - 3 - Screws
  - 3 - Wire nuts
  - 1 - Snap bushing
  - 1 - Snap plug
  - 1 - Wire tie
  - 1 - Condensate trap
  - 1 - Condensate trap cap
  - 2 - 2" diameter vent / intake plugs
  - 1 - 3" diameter cabinet plug (intake)
  - 1 - 2" diameter debris screen

**NOTE** - G43UF-48C-110, G43UF-110H and G43UF-60C-110 units also include a 2" diameter PVC street elbow, which is shipped on the blower deck in the heating compartment. G43UF-60D-135 units are shipped with a 3" to 2" PVC reducing elbow.

**Canadian Installations Only** - Replace the provided 2" street elbow shipped with the G43UF-110, G43UF-110H and G43UF-60C-110 units with 2" street elbow Y0162. Replace the provided 3" X 2" reducing elbow shipped with the G43UF-60D-135 units with 3" X 2" reducing elbow 40W22. Y0162 and 40W22 meet B149 vent requirements.

## ⚠ DANGER

**Danger of explosion.**

**There are circumstances in which odorant used with LP/propane gas can lose its scent. In case of a leak, LP/propane gas will settle close to the floor and may be difficult to smell. An LP/propane leak detector should be installed in all LP applications.**

Check equipment for shipping damage. If you find any damage, immediately contact the last carrier.

The following items may also be ordered separately:

- 1 - Thermostat
- 1 - Propane/LP changeover kit

## Safety Information

## ⚠ WARNING

**Improper installation, adjustment, alteration, service or maintenance can cause property damage, personal injury or loss of life. Installation and service must be performed by a licensed professional installer (or equivalent), service agency or the gas supplier.**

## ⚠ CAUTION

**As with any mechanical equipment, personal injury can result from contact with sharp sheet metal edges. Be careful when you handle this equipment.**

Use only the type of gas approved for use with this furnace. Refer to unit nameplate.

G43UF units are CSA International certified to ANSI Z21.47 and CSA 2.3 standards.

In the USA, installation of gas furnaces must conform with local building codes. In the absence of local codes, units must be installed according to the current National Fuel Gas Code (ANSI-Z223.1/NFPA 54). The National Fuel Gas Code is available from the following address:

American National Standards Institute, Inc.  
11 West 42nd Street  
New York, NY 10036

In Canada, installation must conform with current National Standard of Canada CSA-B149 Natural Gas and Propane Installation Codes, local plumbing or waste water codes and other applicable local codes.

In order to ensure proper unit operation in non-direct vent applications, combustion and ventilation air supply must be provided according to the current National Fuel Gas Code or CSA-B149 standard.

This furnace is CSA International certified for installation clearances to combustible material as listed on the unit nameplate and in the table in figure 8. Accessibility and service clearances must take precedence over fire protection clearances.

**NOTE** - For installation on combustible floors, the furnace shall not be installed directly on carpeting, tile, or other combustible material other than wood flooring.

For installation in a residential garage, the furnace must be installed so that the burner(s) and the ignition source are located no less than 18 inches (457 mm) above the floor. The furnace must be located or protected to avoid physical damage by vehicles. When a furnace is installed in a public garage, hangar, or other building that has a hazardous atmosphere, the furnace must be installed according to recommended good practice requirements and current National Fuel Gas Code or CSA B149 standards.

**NOTE** - Furnace must be adjusted to obtain a temperature rise within the range specified on the unit nameplate. Failure to do so may cause erratic limit operation and premature heat exchanger failure.

This G43UF furnace must be installed so that its electrical components are protected from water.

When this furnace is used with cooling units, it shall be installed in parallel with, or on the upstream side of, cooling units to avoid condensation in the heating compartment. With a parallel flow arrangement, a damper (or other means to control the flow of air) must adequately prevent chilled air from entering the furnace. If the damper is manually operated, it must be equipped to prevent operation of either the heating or the cooling unit, unless it is in the full **HEAT** or **COOL** setting.

When installed, this furnace must be electrically grounded according to local codes. In addition, in the United States, installation must conform with the current National Electric Code, ANSI/NFPA No. 70. The National Electric Code (ANSI/NFPA No. 70) is available from the following address:

National Fire Protection Association  
1 Battery March Park  
Quincy, MA 02269

In Canada, all electrical wiring and grounding for the unit must be installed according to the current regulations of the Canadian Electrical Code Part I (CSA Standard C22.1) and/or local codes.

**NOTE** - This furnace is designed for a minimum continuous return air temperature of 60°F (16°C) or an intermittent operation down to 55°F (13°C) dry bulb for cases where a night setback thermostat is used. Return air temperature must not exceed 85°F (29°C) dry bulb.

The G43UF furnace may be installed in alcoves, closets, attics, basements, garages, and utility rooms in the upflow position.

This furnace design has not been CSA certified for installation in mobile homes, recreational vehicles, or outdoors.

Never use an open flame to test for gas leaks. Check all connections using a commercially available soap solution made specifically for leak detection.

### Use of Furnace as Construction Heater

Lennox does not recommend the use of G43UF units as a construction heater during any phase of construction. Very low return air temperatures, harmful vapors and operation of the unit with clogged or misplaced filters will damage the unit.

G43UF units may be used for heating of buildings or structures under construction, if the following conditions are met:

- The vent system must be permanently installed per these installation instructions.
- A room thermostat must control the furnace. The use of fixed jumpers that will provide continuous heating is not allowed.
- The return air duct must be provided and sealed to the furnace.
- Return air temperature range between 60°F (16°C) and 80°F (27°C) must be maintained.
- Air filters must be installed in the system and must be maintained during construction.
- Air filters must be replaced upon construction completion.
- The input rate and temperature rise must be set per the furnace rating plate.
- One hundred percent (100%) outdoor air must be provided for combustion air requirements during construction. Temporary ducting may supply outdoor air to the furnace. Do not connect duct directly to the furnace. Size the temporary duct following these instructions in section for Combustion, Dilution and Ventilation Air in a confined space with air from outside.
- The furnace heat exchanger, components, duct system, air filters and evaporator coils must be thoroughly cleaned following final construction clean-up.
- All furnace operating conditions (including ignition, input rate, temperature rise and venting) must be verified according to these installation instructions.

### General

These instructions are intended as a general guide and do not supersede local codes in any way. Consult authorities having jurisdiction before installation.

In addition to the requirements outlined previously, the following general recommendations must be considered when installing a G43UF furnace:

- Place the furnace as close to the center of the air distribution system as possible. The furnace should also be located close to the chimney or vent termination point.
- When the furnace is installed in non-direct vent applications, do not install the furnace where drafts might blow directly into it. This could cause improper combustion and unsafe operation.
- When the furnace is installed in non-direct vent applications, do not block the furnace combustion air opening with clothing, boxes, doors, etc. Air is needed for proper combustion and safe unit operation.
- When the furnace is installed in an attic or other insulated space, keep insulation away from the furnace.
- When the furnace is installed in an unconditioned space, consider provisions required to prevent freezing of condensate drain system.

## ⚠ CAUTION

**G43UF unit should not be installed in areas normally subject to freezing temperatures.**

## ⚠ WARNING

**Product contains fiberglass wool.**

**Disturbing the insulation in this product during installation, maintenance, or repair will expose you to fiberglass wool. Breathing this may cause lung cancer. (Fiberglass wool is known to the State of California to cause cancer.)**

**Fiberglass wool may also cause respiratory, skin, and eye irritation.**

**To reduce exposure to this substance or for further information, consult material safety data sheets available from address shown below, or contact your supervisor.**

**Lennox Industries Inc.  
P.O. Box 799900  
Dallas, TX 75379-9900**

## Combustion, Dilution & Ventilation Air

**If the G43UF is installed as a Non-Direct Vent Furnace, follow the guidelines in this section.**

**NOTE** - *In Non-Direct Vent installations, combustion air is taken from indoors and flue gases are discharged outdoors.*

## ⚠ WARNING

**Insufficient combustion air can cause headaches, nausea, dizziness or asphyxiation. It will also cause excess water in the heat exchanger resulting in rusting and premature heat exchanger failure. Excessive exposure to contaminated combustion air will result in safety and performance related problems. Avoid exposure to the following substances in the combustion air supply:**

**Permanent wave solutions**

**Chlorinated waxes and cleaners**

**Chlorine base swimming pool chemicals**

**Water softening chemicals**

**De-icing salts or chemicals**

**Carbon tetrachloride**

**Halogen type refrigerants**

**Cleaning solvents (such as perchloroethylene)**

**Printing inks, paint removers, varnishes, etc.**

**Hydrochloric acid**

**Cements and glues**

**Antistatic fabric softeners for clothes dryers**

**Masonry acid washing materials**

In the past, there was no problem in bringing in sufficient outdoor air for combustion. Infiltration provided all the air that was needed. In today's homes, tight construction practices make it necessary to bring in air from outside for combustion. Take into account that exhaust fans, appliance vents, chimneys, and fireplaces force additional air that could be used for combustion out of the house. Unless outside air is brought into the house for combustion, negative pressure (outside pressure is greater than inside pressure) will build to the point that a downdraft can occur in the furnace vent pipe or chimney. As a result, combustion gases enter the living space creating a potentially dangerous situation.

In the absence of local codes concerning air for combustion and ventilation, use the guidelines and procedures in this section to install G43UF furnaces to ensure efficient and safe operation. You must consider combustion air needs and requirements for exhaust vents and gas piping. A portion of this information has been reprinted with permission from the National Fuel Gas Code (ANSI-Z223.1/NFPA 54). This reprinted material is not the complete and official position of the ANSI on the referenced subject, which is represented only by the standard in its entirety.

In Canada, refer to the CSA B149 installation codes.

## ⚠ CAUTION

**Do not install the furnace in a corrosive or contaminated atmosphere. Meet all combustion and ventilation air requirements, as well as all local codes.**

All gas-fired appliances require air for the combustion process. If sufficient combustion air is not available, the furnace or other appliance will operate inefficiently and unsafely. Enough air must be provided to meet the needs of all fuel-burning appliances and appliances such as exhaust fans which force air out of the house. When fireplaces, exhaust fans, or clothes dryers are used at the same time as the furnace, much more air is required to ensure proper combustion and to prevent a downdraft. Insufficient air causes incomplete combustion which can result in carbon monoxide.

In addition to providing combustion air, fresh outdoor air dilutes contaminants in the indoor air. These contaminants may include bleaches, adhesives, detergents, solvents and other contaminants which can corrode furnace components.

The requirements for providing air for combustion and ventilation depend largely on whether the furnace is installed in an unconfined or a confined space.

### Unconfined Space

An unconfined space is an area such as a basement or large equipment room with a volume greater than 50 cubic feet (1.42 m<sup>3</sup>) per 1,000 Btu (.29 kW) per hour of the combined input rating of all appliances installed in that space. This space also includes adjacent rooms which are not separated by a door. Though an area may appear to be unconfined, it might be necessary to bring in outdoor air for combustion if the structure does not provide enough air by infiltration. If the furnace is located in a building of tight construction with weather stripping and caulking around the windows and doors, follow the procedures in the air from outside section.

### Confined Space

A confined space is an area with a volume less than 50 cubic feet (1.42 m<sup>3</sup>) per 1,000 Btu (.29 kW) per hour of the combined input rating of all appliances installed in that space. This definition includes furnace closets or small equipment rooms. When the furnace is installed so that supply ducts carry air circulated by the furnace to areas outside the space containing the furnace, the return air **must be** handled by ducts which are sealed to the furnace casing and which terminate outside the space containing the furnace. This is especially important when the furnace is mounted on a platform in a

confined space such as a closet or small equipment room. Even a small leak around the base of the unit at the platform or at the return air duct connection can cause a potentially dangerous negative pressure condition. Air for combustion and ventilation can be brought into the confined space either from inside the building or from outside.

### Air from Inside

If the confined space that houses the furnace adjoins a space categorized as unconfined, air can be brought in by providing two permanent openings between the two spaces. Each opening must have a minimum free area of 1 square inch (645 mm<sup>2</sup>) per 1,000 Btu (.29 kW) per hour of total input rating of all gas-fired equipment in the confined space. Each opening must be at least 100 square inches (64516 mm<sup>2</sup>). One opening shall be within 12 inches (305 mm) of the top of the enclosure and one opening within 12 inches (305 mm) of the bottom. See figure 3.

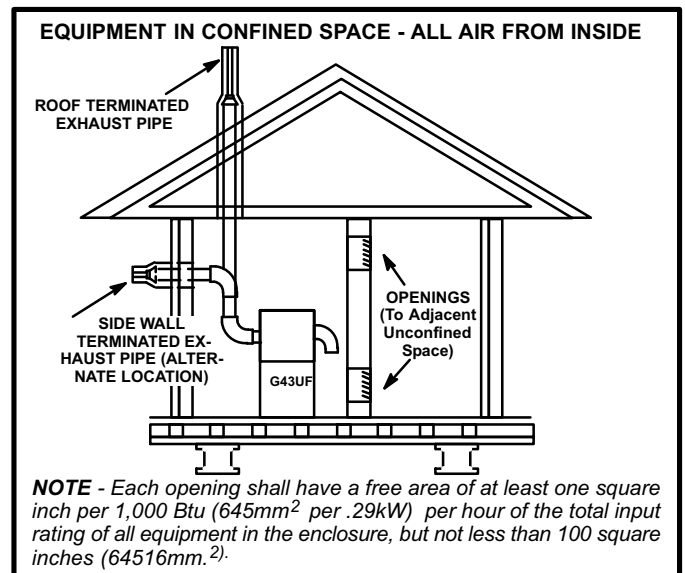
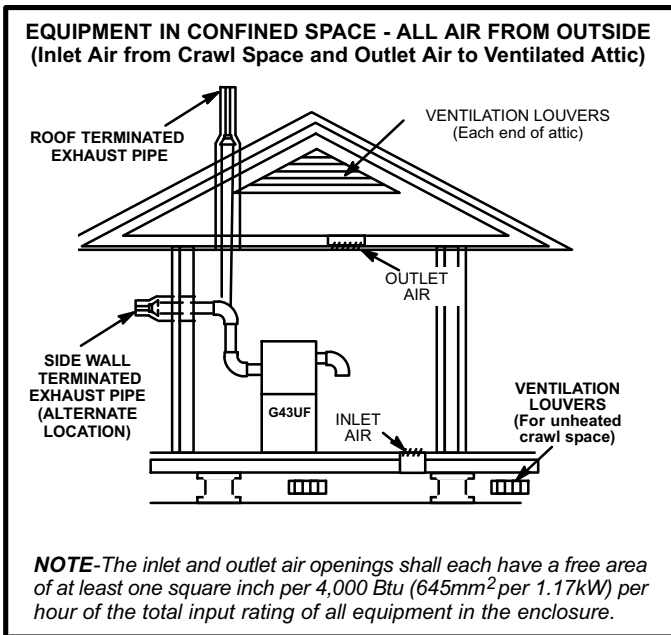

FIGURE 3

### Air from Outside

If air from outside is brought in for combustion and ventilation, the confined space shall be provided with two permanent openings. One opening shall be within 12" (305mm) of the top of the enclosure and one within 12" (305mm) of the bottom. These openings must communicate directly or by ducts with the outdoors or spaces (crawl or attic) that freely communicate with the outdoors or indirectly through vertical ducts. Each opening shall have a minimum free area of 1 square inch per 4,000 Btu (645mm<sup>2</sup> per 1.17kW) per hour of total input rating of all equipment in the enclosure. When communicating with the outdoors through horizontal ducts, each opening shall have a minimum free area of 1 square inch per 2,000 Btu (645mm<sup>2</sup> per .59kW) per total input rating of all equipment in the enclosure (See figure 4).



**FIGURE 4**

If air from outside is brought in for combustion and ventilation, the confined space must have two permanent openings. One opening shall be within 12 inches (305 mm) of the top of the enclosure and one opening within 12 inches (305 mm) of the bottom. These openings must communicate directly or by ducts with the outdoors or spaces (crawl or attic) that freely communicate with the outdoors or indirectly through vertical ducts. Each opening shall have a minimum free area of 1 square inch (645 mm<sup>2</sup>) per 4,000 Btu (1.17 kW) per hour of total input rating of all equipment in the enclosure. See figures 4 and 5. When communicating with the outdoors through horizontal ducts, each opening shall have a minimum free area of 1 square inch (645 mm<sup>2</sup>) per 2,000 Btu (.56 kW) per total input rating of all equipment in the enclosure. See figure 6.

When ducts are used, they shall be of the same cross-sectional area as the free area of the openings to which they connect. The minimum dimension of rectangular air ducts shall be no less than 3 inches (75 mm). In calculating free area, the blocking effect of louvers, grilles, or screens must be considered. If the design and free area of protective covering is not known for calculating the size opening required, it may be assumed that wood louvers will have 20 to 25 percent free area and metal louvers and grilles will have 60 to 75 percent free area. Louvers and grilles must be fixed in the open position or interlocked with the equipment so that they are opened automatically during equipment operation.

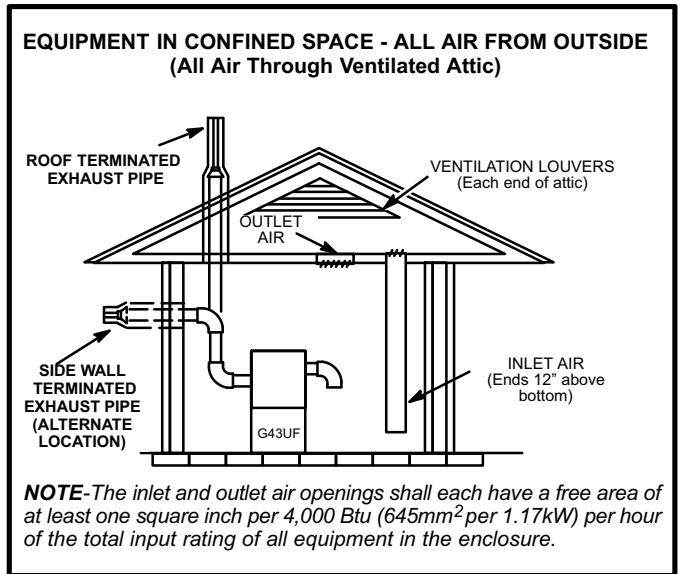

**FIGURE 5**

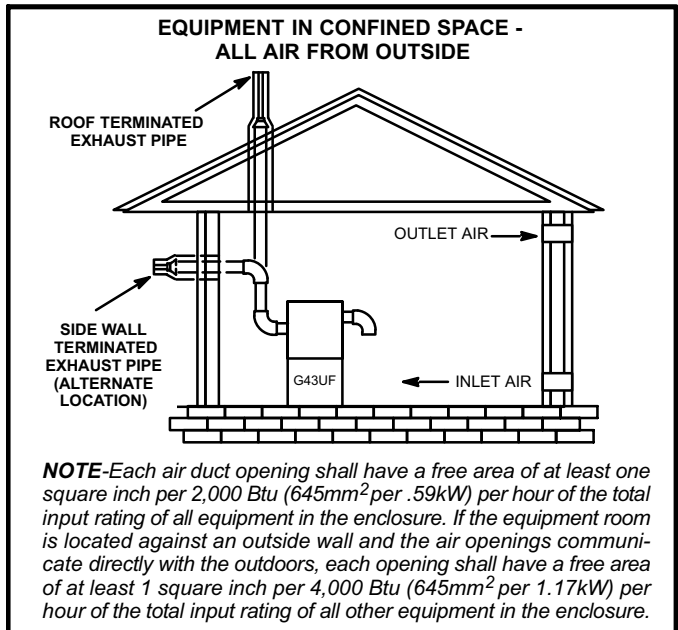

**FIGURE 6**

**Installation - Setting Equipment**

**⚠ WARNING**

**Do not install the furnace on its front or its back. Do not connect the return air ducts to the back of the furnace. Doing so will adversely affect the operation of the safety control devices, which could result in personal injury or death.**



The G43UF gas furnace can be installed as shipped in the upflow position only. Refer to figure 8 for clearances. Select a location that allows for the required clearances that are listed on the unit nameplate. Also consider gas supply connections, electrical supply, vent connection, condensate trap and drain connections, and installation and service clearances [24 inches (610 mm) at unit front]. *The unit must be level from front to back and side to side. The unit may be tilted slightly (maximum 1/2 in.) from back to front to aid in the draining of the heat exchanger. See figure 7.*

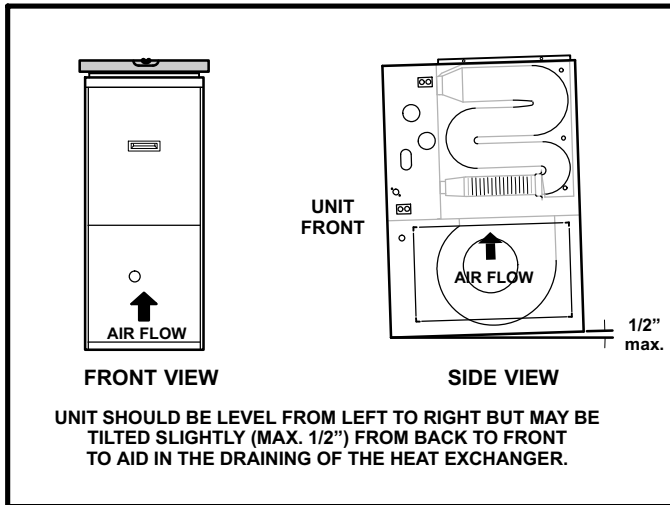

FIGURE 7

**NOTE** - 1/3 hp blower motors are equipped with four flexible mounting legs, and 1/2 hp blower motors are equipped with three flexible legs and one rigid leg. The rigid leg is equipped with a shipping bolt and a flat white plastic washer (rather than the rubber mounting grommet used with a flexible mounting leg). **The bolt and washer must be removed before the furnace is placed into operation.** After the bolt and washer have been removed, the rigid leg will not touch the blower housing.

**NOTE** - G43UF-60D-135 units are equipped with a shipping pad under the blower housing. Remove the shipping pad prior to operation.

Allow for clearances to combustible materials as indicated on the unit nameplate. Minimum clearances for closet or alcove installations are shown in figure 8.

## ⚠ WARNING

**Blower access panel must be securely in place when blower and burners are operating. Gas fumes, which could contain carbon monoxide, can be drawn into living space resulting in personal injury or death.**

## ⚠ WARNING

**Improper installation of the furnace can result in personal injury or death. Combustion and flue products must never be allowed to enter the return air system or air in the living space. Use sheet metal screws and joint tape to seal return air system to furnace. In platform installations with furnace return, the furnace should be sealed airtight to the return air plenum. A door must never be used as a portion of the return air duct system. The base must provide a stable support and an airtight seal to the furnace. Allow absolutely no sagging, cracks, gaps, etc. For no reason should return and supply air duct systems ever be connected to or from other heating devices such as a fireplace or stove, etc. Fire, explosion, carbon monoxide poisoning, personal injury and/or property damage could result.**

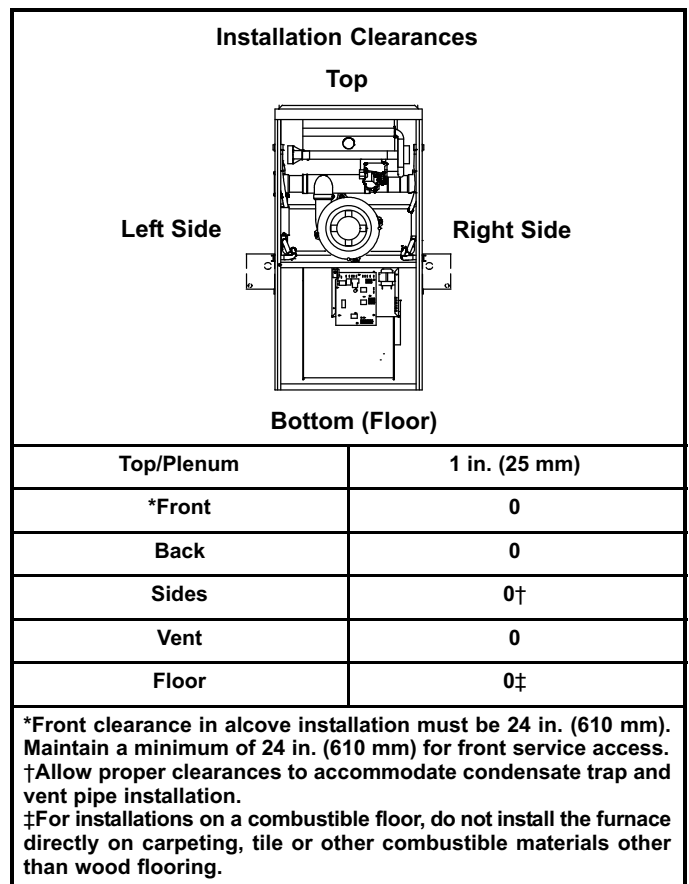

FIGURE 8

### Return Air Guidelines

Return air can be brought in through the bottom or either side of the furnace installed in an upflow application. If the furnace is installed on a platform with bottom return, make an airtight seal between the bottom of the furnace and the platform to ensure that the furnace operates properly and safely. The furnace is equipped with a removable bottom panel to facilitate installation.

Markings are provided on both sides of the furnace cabinet for installations that require side return air. Cut the furnace cabinet at the maximum dimensions shown on page 2.

**NOTE - When air volumes over 1800 cfm (850 L/s) are required with 60C or 60D models in an upflow application, the following return air options are available:**

- 1 - Return air from single side with transition which will accommodate 20 x 25 x 1 in. (508 x 635 x 25 mm) air filter. (Required to maintain proper air velocity.) See figure 9.
- 2 - Return air from single side with optional RAB Return Air Base. See figure 10.
- 3 - Return air from bottom.
- 4 - Return air from both sides.
- 5 - Return air from bottom and one side.

Refer to Engineering Handbook for additional information.

**G43UF applications which include side return air and a condensate trap installed on the same side of the cabinet require either a return air base or field-fabricated transition to accommodate an optional IAQ accessory taller than 14-1/2".**

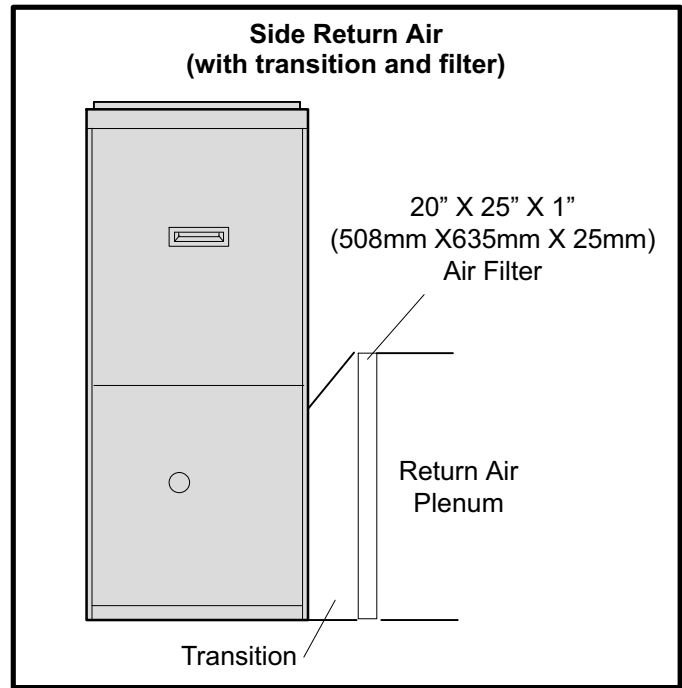

**FIGURE 9**

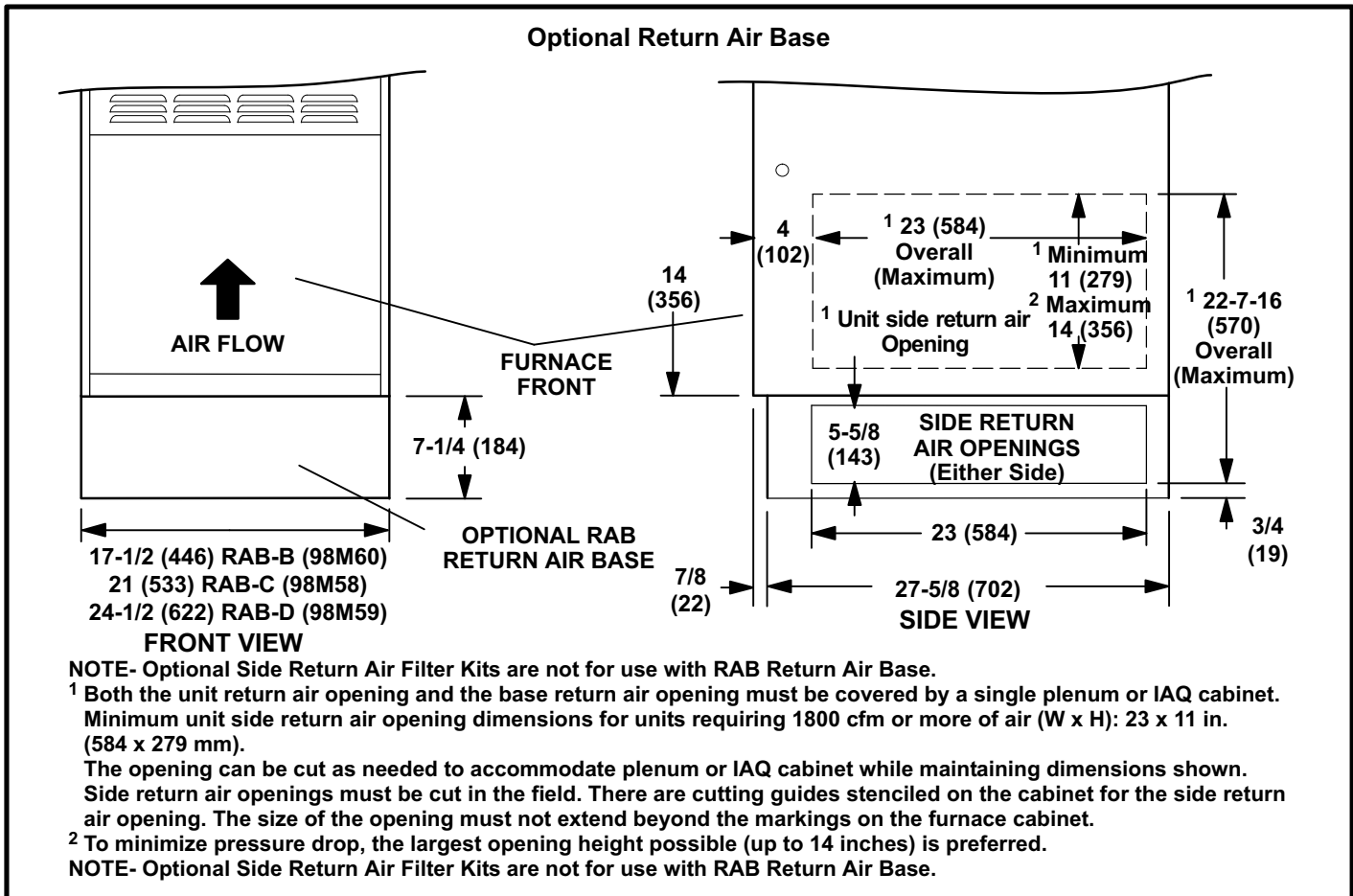

**FIGURE 10**

**NOTE-** Optional Side Return Air Filter Kits are not for use with RAB Return Air Base.

<sup>1</sup> Both the unit return air opening and the base return air opening must be covered by a single plenum or IAQ cabinet. Minimum unit side return air opening dimensions for units requiring 1800 cfm or more of air (W x H): 23 x 11 in. (584 x 279 mm).

The opening can be cut as needed to accommodate plenum or IAQ cabinet while maintaining dimensions shown.

Side return air openings must be cut in the field. There are cutting guides stenciled on the cabinet for the side return air opening. The size of the opening must not extend beyond the markings on the furnace cabinet.

<sup>2</sup> To minimize pressure drop, the largest opening height possible (up to 14 inches) is preferred.

**NOTE-** Optional Side Return Air Filter Kits are not for use with RAB Return Air Base.

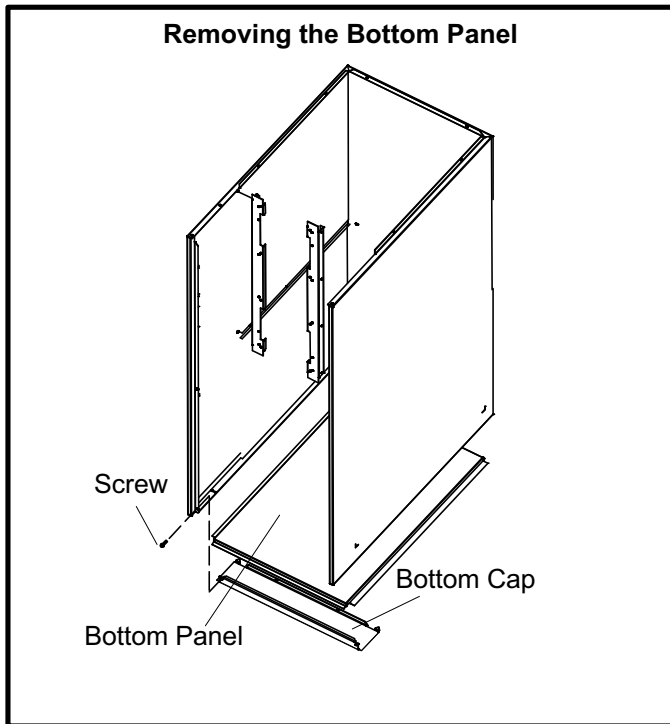

FIGURE 11

### Removing the Bottom Panel

Remove the two screws that secure the bottom cap to the furnace. Pivot the bottom cap down to release the bottom panel. Once the bottom panel has been removed, reinstall the bottom cap. See figure 11.

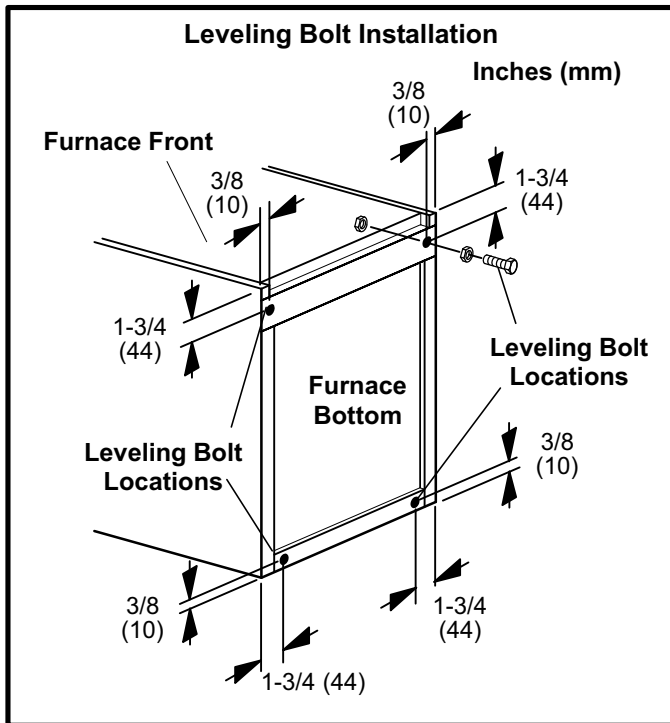

FIGURE 12

### Leveling an Upflow Unit

When the side return air inlets are used in an upflow application, it may be necessary to install leveling bolts on the bottom of the furnace. Use field-supplied corrosion-resistant 5/16 inch machine bolts (4) and nuts (8). See figure 12.

**NOTE** - The maximum length of the bolt is 1-1/2 inches.

- 1 - Lay the furnace on its back and drill a 5/16 inch diameter hole in each corner of the furnace's bottom. See figure 12 for the correct location of the holes. Drill through the bottom panel and the bottom flange of the cabinet.
- 2 - Install one bolt and two nuts into each hole. Screw the first nut onto a bolt and then insert the bolt into a hole. A flat washer may be added between the nut and the bottom of the unit.
- 3 - Screw another nut onto the bolt on the inside of the furnace base. A flat washer may be added between the nut and the bottom of the unit.
- 4 - Adjust the outside nut to the appropriate height and tighten the inside nut to secure the arrangement.

**NOTE** - The unit may be tilted back-to-front a maximum of 1/2". This will ensure proper draining of the heat exchanger.

### Filters

This unit is not equipped with a filter or rack. A field-provided filter is required for the unit to operate properly. Table 1 lists recommended filter sizes.

A filter must be in place whenever the unit is operating.

TABLE 1

Furnace Cabinet Width	Filter Size	
	Side Return	Bottom Return
17-1/2"	16 X 25 X 1 (1)	16 X 25 X 1 (1)
21"	16 X 25 X 1 (1)	20 X 25 X 1 (1)
24-1/2"	16 X 25 X 1 (2)	24 X 25 X 1 (1)

### Duct System

Use industry-approved standards to size and install the supply and return air duct system. This will result in a quiet and low-static system that has uniform air distribution.

**NOTE** - Operation of this furnace in heating mode (indoor blower operating at selected heating speed) with an external static pressure which exceeds 0.5 inches w.c. may result in erratic limit operation.

### Supply Air Plenum

If the furnace is installed without a cooling coil, a removable access panel should be installed in the supply air duct. The access panel should be large enough to permit inspection (by reflected light) of the heat exchanger for leaks after the furnace is installed. The furnace access panel must always be in place when the furnace is operating and it must not allow leaks into the supply air duct system.

## Return Air Plenum

**NOTE - Return air must not be drawn from a room where this furnace, or any other gas-fueled appliance (i.e., water heater), or carbon monoxide-producing device (i.e., wood fireplace) is installed.**

When return air is drawn from a room, a negative pressure is created in the room. If a gas appliance is operating in a room with negative pressure, the flue products can be pulled back down the vent pipe and into the room. This reverse flow of the flue gas may result in incomplete combustion and the formation of carbon monoxide gas. This toxic gas might then be distributed throughout the house by the furnace duct system.

Return air can be brought in through the bottom or either side of the furnace. If a furnace with bottom return air is installed on a platform, make an airtight seal between the bottom of the furnace and the platform to ensure that the unit operates properly and safely. Use fiberglass sealing strips, caulking, or equivalent sealing method between the plenum and the furnace cabinet to ensure a tight seal. If a filter is installed, size the return air duct to fit the filter frame.

### Pipe & Fittings Specifications

All pipe, fittings, primer and solvent cement must conform with American National Standard Institute and the American Society for Testing and Materials (ANSI/ASTM) standards. The solvent shall be free flowing and contain no lumps, undissolved particles or any foreign matter that adversely affects the joint strength or chemical resistance of the cement. The cement shall show no gelation, stratification, or separation that cannot be removed by stirring. Refer to the table 2 below for approved piping and fitting materials.

## ⚠ CAUTION

**Solvent cements for plastic pipe are flammable liquids and should be kept away from all sources of ignition. Do not use excessive amounts of solvent cement when making joints. Good ventilation should be maintained to reduce fire hazard and to minimize breathing of solvent vapors. Avoid contact of cement with skin and eyes.**

**TABLE 2  
PIPING AND FITTINGS SPECIFICATIONS**

PIPE & FITTING MATERIAL	ASTM SPECIFICATION
Schedule 40 PVC (Pipe)	D1785
Schedule 40 PVC (Cellular Core Pipe)	F891
Schedule 40 PVC (Fittings)	D2466
Schedule 40 CPVC (Pipe)	F441
Schedule 40 CPVC (Fittings)	F438
SDR-21 PVC or SDR-26 PVC (Pipe)	D2241
SDR-21 CPVC or SDR-26 CPVC (Pipe)	F442
Schedule 40 ABS Cellular Core DWV (Pipe)	F628
Schedule 40 ABS (Pipe)	D1527
Schedule 40 ABS (Fittings)	D2468
ABS-DWV (Drain Waste & Vent) (Pipe & Fittings)	D2661
PVC-DWV (Drain Waste & Vent) Pipe & Fittings)	D2665
PRIMER & SOLVENT CEMENT	ASTM SPECIFICATION
PVC & CPVC Primer	F656
PVC Solvent Cement	D2564
CPVC Solvent Cement	F493
ABS Solvent Cement	D2235
PVC/CPVC/ABS All Purpose Cement For Fittings & Pipe of the same material	D2564, D2235, F493
ABS to PVC or CPVC Transition Solvent Cement	D3138
CANADA PIPE & FITTING & SOLVENT CEMENT	MARKING
PVC & CPVC Pipe and Fittings	ULCS636
PVC & CPVC Solvent Cement	
ABS to PVC or CPVC Transition Cement	

Use PVC primer and solvent cement or ABS solvent cement meeting ASTM specifications, refer to Table 2. As an alternate, use all purpose cement, to bond ABS, PVC, or CPVC pipe when using fittings and pipe made of the same materials. Use transition solvent cement when bonding ABS to either PVC or CPVC.

Low temperature solvent cement is recommended. Metal or plastic strapping may be used for vent pipe hangers. Uniformly apply a liberal coat of PVC primer for PVC or use a clean dry cloth for ABS to clean inside socket surface of fitting and male end of pipe to depth of fitting socket.

**Canadian Applications Only - Pipe, fittings, primer and solvent cement used to vent (exhaust) this appliance must be certified to ULC S636 and supplied by a single manufacturer as part of an approved vent (exhaust) system. When bonding the vent system to the furnace, use ULC S636 approved One-Step Transition Cement to bond the pipe to the flue collar, or to bond the 90° elbow or reducing 90° elbow to the flue collar. In addition, the first three feet of vent pipe from the furnace flue collar must be accessible for inspection.**

Table 3 lists the available exhaust termination kits, as well as vent pipe equivalencies which must be used when sizing vent pipe. All Lennox vent terminations are PVC.

**TABLE 3  
OUTDOOR TERMINATION KITS AND CORRESPONDING EQUIVALENCIES**

UNIT MODEL	VENT PIPE DIA. (in.)	Vent Pipe Length Equivalency (feet)							
		Outdoor Exhaust Accelerator (Dia. X Length)	Outdoor Exhaust Accelerator (Dia. X Length)	1-1/2" Concentric Kit	2" Concentric Kit	3" Concentric Kit	2" Wall Plate Kit	3" Wall Plate Kit	2" Wall Ring Kit
		1-1/2" X 12"	2" X 12"	71M80 or 44W92†	69M29 or 44W92†	60L46 or 44W93†	22G44 or 30G28†	44J40 or 81J20†	15F74
24B-045	2	4	Not Allowed	12	Not Allowed	Not Allowed	4	4*	4
	2-1/2	5	Not Allowed	15	Not Allowed	Not Allowed	5	5*	5
	3	7	Not Allowed	21	Not Allowed	Not Allowed	7	7*	7
	4	14	Not Allowed	42	Not Allowed	Not Allowed	14	14*	14
24B-070 36B-070	2	4	Not Allowed	12	Not Allowed	Not Allowed	4	4*	4
	2-1/2	5	Not Allowed	15	Not Allowed	Not Allowed	5	5*	5
	3	8	Not Allowed	24	Not Allowed	Not Allowed	8	8*	8
	4	14	Not Allowed	42	Not Allowed	Not Allowed	14	14*	14
36C-090 36C-090H 48C-090	2	Not Allowed	1	Not Allowed	3	3	Not Allowed	1	1**
	2-1/2	Not Allowed	2	Not Allowed	6	6	Not Allowed	2	2**
	3	Not Allowed	2	Not Allowed	6	6	Not Allowed	2	2**
	4	Not Allowed	4	Not Allowed	12	12	Not Allowed	4	4**
48C-110 48C-110H 60C-110	2	Not Allowed	1	Not Allowed	3	3	Not Allowed	1	1**
	2-1/2	Not Allowed	2	Not Allowed	6	6	Not Allowed	2	2***
	3	Not Allowed	2	Not Allowed	6	6	Not Allowed	2	2***
	4	Not Allowed	4	Not Allowed	12	12	Not Allowed	4	4***
60D-135	3	Not Allowed	6	Not Allowed	Not Allowed	15	Not Allowed	6	6***
	4	Not Allowed	10	Not Allowed	Not Allowed	25	Not Allowed	10	10***

\*Requires field-provided and installed 1-1/2" exhaust accelerator.

\*\*Requires field-provided and installed 2" exhaust accelerator.

\*\*\*For use only in non-direct vent applications, when snow riser is not required. Requires field-provided and installed 2" exhaust accelerator.

† Termination kits 44W92 (includes 1-1/2" reducer), 44W93, 30G28 and 81J20 approved for use in Canadian installations.

## Vent Piping Guidelines

The G43UF can be installed as either a Non-Direct Vent or a Direct Vent gas central furnace.

**NOTE** - In Non-Direct Vent installations, combustion air is taken from indoors and flue gases are discharged outdoors. In Direct Vent installations, combustion air is taken from outdoors and flue gases are discharged outdoors.

Intake and exhaust pipe sizing in Direct Vent applications and exhaust pipe sizing in Non-Direct Vent applications -- Size pipe according to tables 4 and 5. Table 4 lists the minimum equivalent vent pipe lengths permitted. Table 5 lists the maximum equivalent pipe lengths permitted.

**Maximum vent length is defined as:**

- Total length (linear feet) of pipe,
- Plus** Equivalent length (feet) of fittings,
- Plus** Equivalent length (feet) of termination.

**NOTE** - Include ALL pipe and ALL fittings, both indoors and outdoors.

Regardless of the diameter of pipe used, the standard roof and wall terminations described in section *Exhaust Piping Terminations* should be used. Exhaust vent termination pipe is sized to optimize the velocity of the exhaust gas as it exits the termination. Refer to table 6.

**NOTE** - The exhaust pipe should be offset a minimum of 12 inches to avoid the possibility of water droplets being released from the exhaust termination. The minimum exhaust vent length is 15 ft. Shorter exhaust vent lengths may result in the discharge of water droplets from the exhaust termination, in spite of the 12-inch vertical offset.

Each 90° elbow (including those provided with the furnace) of any diameter is equivalent to 5 feet (1.52m) of vent pipe of the same diameter. Two 45° elbows are equivalent to one 90° elbow of the same diameter. One 45° elbow is equal to 2.5 feet (.76m) of vent pipe of the same diameter.

In some applications which permit the use of several different sizes of vent pipe, a combination vent pipe may be used. Contact the Application Department for assistance in sizing vent pipe in these applications.

**NOTE** - The flue collar on all models is sized to accommodate 2" Schedule 40 flue pipe. When vent pipe which is larger than 2" must be used in an upflow application, a 2" elbow must be applied at the flue collar in order to properly transition to the larger diameter flue pipe. This elbow must be added to the elbow count used to determine acceptable vent lengths. Assign an equivalent feet value to this elbow according to the larger size pipe being used. Contact the Application Department for more information concerning sizing of vent systems which include multiple pipe sizes.

Use the following steps to correctly size vent pipe diameter. Refer to **Vent Pipe Size Determination Worksheet on Page 46**.

- 1 - Determine the vent termination and its corresponding equivalent feet value according to table 3.
- 2 - Determine the number of 90° elbows required for both indoor and outdoor (e.g. snow riser) use. Calculate the corresponding equivalent feet of vent pipe.

- 3 - Determine the number of 45° elbows required for both indoor and outdoor use. Calculate the corresponding equivalent feet of vent pipe.
- 4 - Determine the length of straight pipe required.
- 5 - Add the total equivalent feet calculated in steps 1 through 4 and compare that length to the maximum values given in table 5 for the proposed vent pipe diameter. If the total equivalent length required exceeds the maximum equivalent length listed in the appropriate table, evaluate the next larger size pipe.

## ▲ IMPORTANT

**Do not use screens or perforated metal in exhaust terminations. Doing so will cause freeze-ups and may block the terminations.**

**TABLE 4  
MINIMUM VENT PIPE LENGTHS**

G43UF MODEL	MIN. EQUIV. VENT LENGTH	EXAMPLE
045, 070, 090	15 ft.*	5 ft. plus 2 elbows of 2", 2-1/2", 3" or 4" diameter pipe
110**		5 ft. plus 2 elbows of 2", 2-1/2", 3" or 4" diameter pipe
135***		5 ft. plus 2 elbows of 3" or 4" diameter pipe

\*Any approved termination may be added to the minimum equivalent length listed.

\*\*G43UF-48C-110, G43UF-110H and G43UF-60C-110 must have 90° street ell (supplied or field replacement Canadian kit) installed directly into unit flue collar.

\*\*\*G43UF-60D-135 must have 3" to 2" reducing ell (supplied or field replacement Canadian kit) installed directly into unit flue collar.

**TABLE 5  
MAXIMUM VENT PIPE LENGTHS  
DIRECT (2 PIPE) AND NON-DIRECT (1 PIPE) APPLICATIONS**

ALTITUDE	G43UF MODEL	MAXIMUM EQUIVALENT VENT LENGTH FEET			
		2" dia.	2-1/2" dia.	3" dia.	4" dia.
0 - 2000 (0 - 609 m)	045	110	135	160	250
	070	70	135	160	250
	090	50	100	125	225
	110*	30	70	125	200
	135**	n/a	n/a	***125	180
2001 - 4500 (610 - 1371 m)	045	110	135	160	250
	070	70	135	160	250
	090	50	100	125	225
	110*	20	70	125	200
	135**	n/a	n/a	***90	180
4501-7500 (1372-2286 m)	045	110	135	160	250
	070	70	135	160	250
	090	30	100	125	225
	110*	n/a	70	125	200
	135**	n/a	n/a	***90	180
7501 - 10000 (2287 - 3048 m)	045	110	135	160	250
	070	70	135	160	250
	090	n/a	100	125	225
	110*	n/a	70	125	200
	135**	n/a	n/a	***90	180

n/a -- Not allowed.

\*G43UF-48C-110 and G43UF-60C-110 must have 90° street ell (supplied) installed directly into unit flue collar.

\*\*G43UF-60D-135 must have 3" to 2" reducing ell (supplied) installed directly into unit flue collar.

\*\*\*90° elbows used in configuration of G43UF-60D-135 vent, must be limited to 3" sweep elbows.

## Joint Cementing Procedure

All cementing of joints should be done according to the specifications outlined in ASTM D 2855.

### **⚠ WARNING**

#### **DANGER OF EXPLOSION!**

**Fumes from PVC glue may ignite during system check. Allow fumes to dissipate for at least 5 minutes before placing unit into operation.**

- 1 - Measure and cut vent pipe to desired length.
- 2 - Debur and chamfer end of pipe, removing any ridges or rough edges. If end is not chamfered, edge of pipe may remove cement from fitting socket and result in a leaking joint.
- 3 - Clean and dry surfaces to be joined.
- 4 - Test fit joint and mark depth of fitting on outside of pipe.
- 5 - Uniformly apply a liberal coat of PVC primer for PVC or use a clean dry cloth for ABS to clean inside socket surface of fitting and male end of pipe to depth of fitting socket.

**NOTE** - Furnace flue collar and air inlet fitting are both made of ABS material. Use transition solvent cement when joining ABS fittings to PVC pipe.

- 6 - Promptly apply solvent cement to end of pipe and inside socket surface of fitting. Cement should be applied lightly but uniformly to inside of socket. Take care to keep excess cement out of socket. Apply second coat to end of pipe.

**NOTE** - Time is critical at this stage. Do not allow primer to dry before applying cement.

- 7 - Immediately after applying last coat of cement to pipe, and while both inside socket surface and end of pipe are wet with cement, forcefully insert end of pipe into socket until it bottoms out. Turn PVC pipe 1/4 turn during assembly (but not after pipe is fully inserted) to distribute cement evenly. DO NOT turn ABS or cellular core pipe.

**NOTE** - Assembly should be completed within 20 seconds after last application of cement. Hammer blows should not be used when inserting pipe.

- 8 - After assembly, wipe excess cement from pipe at end of fitting socket. A properly made joint will show a bead around its entire perimeter. Any gaps may indicate a defective assembly due to insufficient solvent.
- 9 - Handle joints carefully until completely set.

## Venting Practices

The thickness of construction through which vent pipes may be installed is 24" (610mm) maximum and 3/4" (19mm) minimum.

- 1 - Use recommended piping materials for exhaust piping.
- 2 - Secure all joints, including drip leg, gas-tight using approved cement.

Suspend piping using hangers at a minimum of every 5 feet (1.52m) for schedule 40 PVC and every 3 feet (.91m) for ABS-DWV, PVC-DWV, SPR-21 PVC, and SDR-26 PVC piping. A suitable hanger can be fabricated by using metal or plastic strapping or a large wire tie.

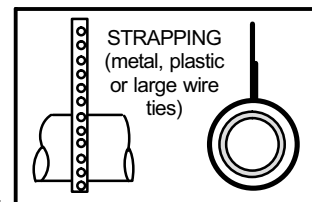

**FIGURE 13**

- 3 - In areas where piping penetrates joists or interior walls, hole must be large enough to allow clearance on all sides of pipe through center of hole using a hanger.
- 4 - Secure piping at the point where it exits the outside wall or roof in order to prevent transmission of vibration to the structure.
- 5 - When furnace is installed in a residence where unit is shut down for an extended period of time, such as a vacation home, make provisions for draining condensate collection trap and lines.

### Exhaust Piping

**NOTE** - A 2" diameter PVC street ell is located on the blower deck of 48C-110, 48C-110H and 60C-110 units (or use field replacement Canadian Kit). **In upflow applications, the street ell must be glued using transition solvent cement directly into the unit flue collar (or use field replacement Canadian Kit). See figure 14. A 3" to 2" PVC reducing ell is located on the blower deck of the 60D-135 units. **In upflow applications, the reducing ell must be glued using transition solvent cement directly into the unit flue collar.****

- 1 - Choose the appropriate side for venting. Glue the field-provided exhaust vent pipe (or provided street ell) to the flue collar. All cement joints should be made according to the specifications outlined in ASTM D 2855. Refer to pipe and fittings specifications and gluing procedures.

### **⚠ IMPORTANT**

**Exhaust piping and condensate trap must be installed on the same side of the unit in upflow and dowflow applications or use alternate drain kit 76M20.**

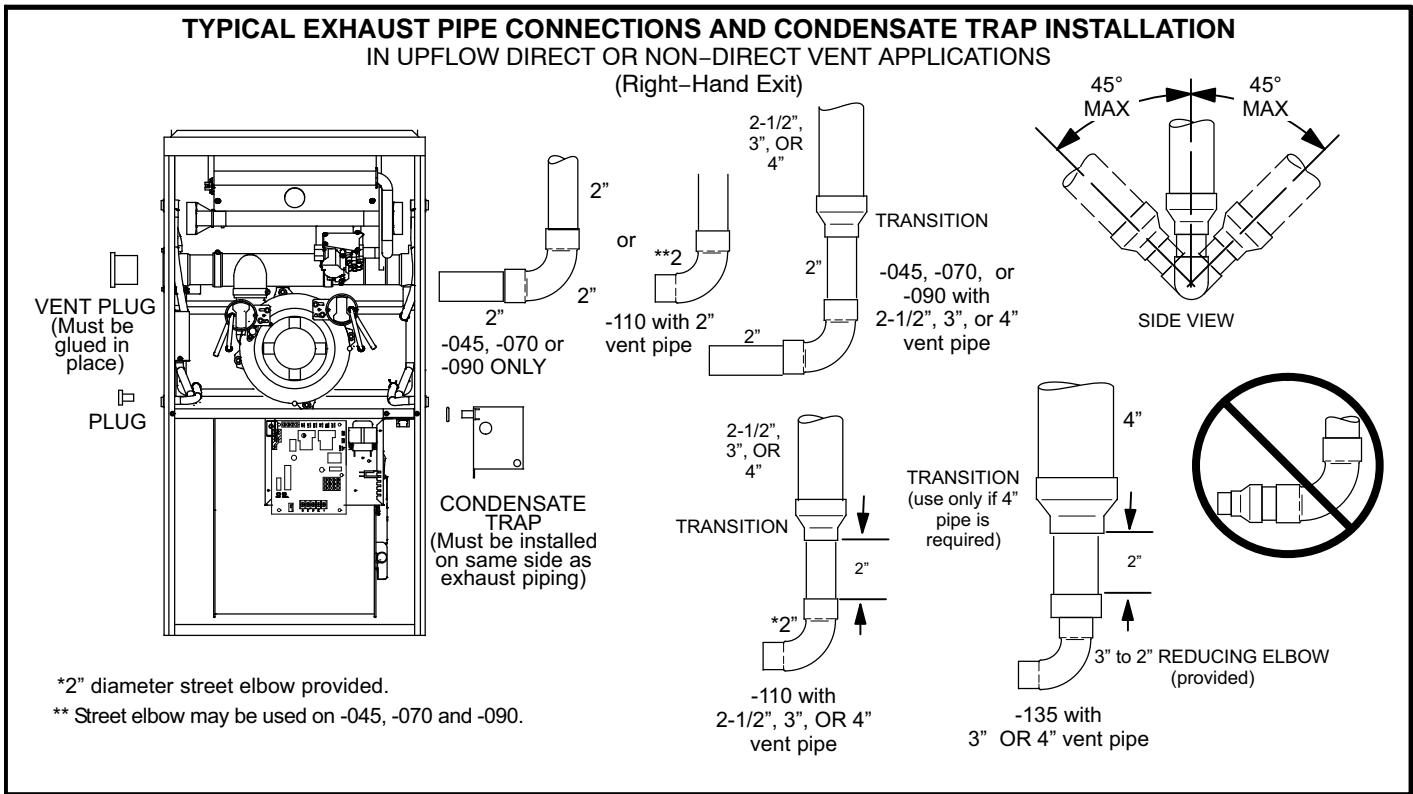
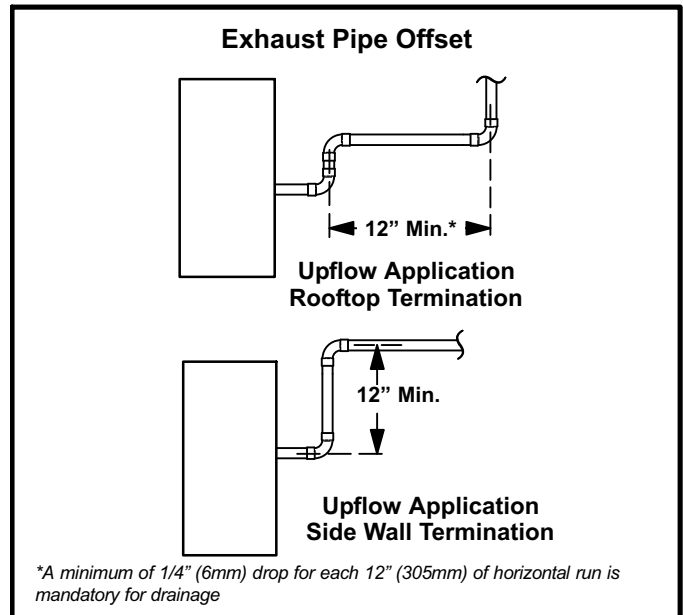

**FIGURE 14**

2 - All horizontal runs of exhaust pipe must slope back toward unit. A minimum of 1/4" (6mm) drop for each 12" (305mm) of horizontal run is mandatory for drainage. Horizontal runs of exhaust piping must be supported every 5 feet (1.52m) using hangers.

**NOTE** - Exhaust piping should be checked carefully to make sure there are no sags or low spots.

- 3 - On the opposite side of the cabinet, glue the provided 2" ABS vent plug into the unused ABS flue collar with ABS or all purpose solvent cement.
- 4 - Route piping to outside of structure. Continue with installation following instructions given in piping termination section.



**FIGURE 15**

## ⚠ CAUTION

Do not discharge exhaust into an existing stack or stack that also serves another gas appliance. If vertical discharge through an existing unused stack is required, insert PVC pipe inside the stack until the end is even with the top or outlet end of the metal stack.

## ⚠ CAUTION

The exhaust vent pipe operates under positive pressure and must be completely sealed to prevent leakage of combustion products into the living space.



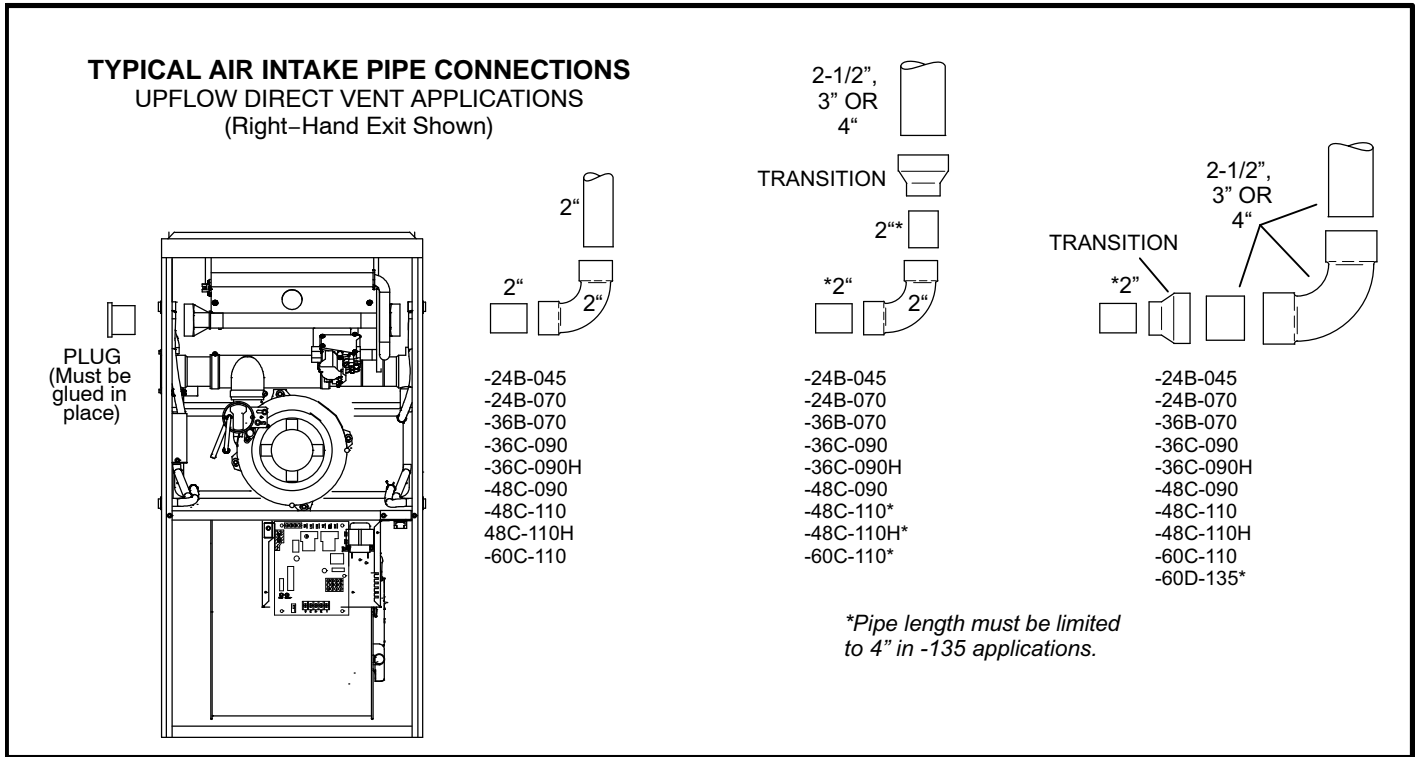

**FIGURE 16**

#### Intake Piping

The G43UF furnace may be installed in either **direct vent** or **non-direct vent** applications. In non-direct vent applications, when intake air will be drawn into the furnace from the surrounding space, the indoor air quality must be considered and guidelines listed in Combustion, Dilution and Ventilation Air section must be followed.

The G43UF unit is designed for either left-side or right-side air intake connections. Intake air piping is independent of exhaust piping.

Follow the next four steps when installing the unit in **Direct Vent applications**, where combustion air is taken from outdoors and flue gases are discharged outdoors. **The provided air intake screen must not be used in direct vent applications.**

- 1 - Use transition solvent cement to connect PVC pipe to the ABS slip connector located on the side of the burner box.
- 2 - Use a sheet metal screw to secure the intake pipe to the connector, if desired. A pilot indentation is provided in the slip connector to assist in locating and starting the fastener.
- 3 - Glue the provided 2" ABS plug into the unused ABS air intake connector on the opposite side of the cabinet with ABS all purpose cement.
- 4 - Route piping to outside of structure. Continue with installation following instructions given in general

guide lines for piping terminations and in intake and exhaust piping terminations for direct vent sections. Refer to figure 16 for pipe sizes.

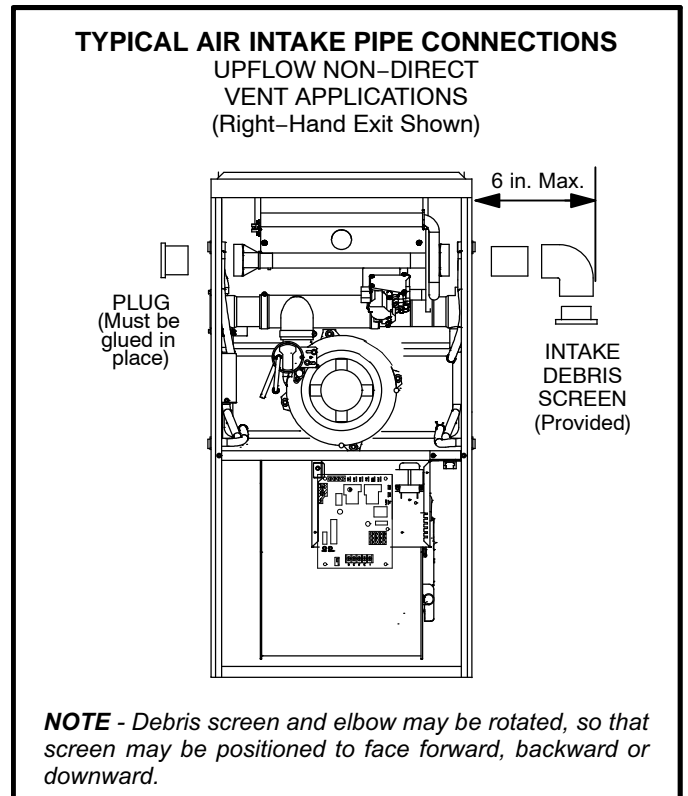

**FIGURE 17**

Follow the next three steps when installing the unit in **Non-Direct Vent applications** where combustion air is taken from indoors and flue gases are discharged outdoors.

- 1 - Use field-provided materials and the factory-provided air intake screen to route the intake piping as shown in figure 17. Maintain a minimum clearance of 3" (76mm) around the air intake opening. The air intake opening (with the protective screen) should always be directed either downward or straight out. Use 2" pipe and fittings only and make sure that the air intake does not extend more than 6" beyond the G43UF cabinet.

**The air intake connector must not be located near the floor.**

- 2 - Use a sheet metal screw to secure the intake pipe to the connector, if desired. A pilot indentation is provided in the slip connector to assist in locating and starting the fastener.
- 3 - Glue the provided 2" plug into the unused air intake connector on the opposite side of the cabinet.

#### General Guidelines for Vent Terminations

In Non-Direct Vent applications, combustion air is taken from indoors and the flue gases are discharged to the outdoors. The G43UF is then classified as a non-direct vent, Category IV gas furnace.

In Direct Vent applications, combustion air is taken from outdoors and the flue gases are discharged to the outdoors. The G43UF is then classified as a direct vent, Category IV gas furnace.

In both Non-Direct Vent and Direct Vent applications, the vent termination is limited by local building codes. In the absence of local codes, refer to the current National Fuel Gas Code ANSI Z223-1/NFPA 54 in U.S.A., and current CSA-B149 Natural Gas and Propane Installation Codes in Canada for details.

Position termination according to location given in figure 18 or 19. In addition, position termination so it is free from any obstructions and 12" above the average snow accumulation.

At vent termination, care must be taken to maintain protective coatings over building materials (prolonged exposure to exhaust condensate can destroy protective coatings). It is recommended that the exhaust outlet not be located within 6 feet (1.8m) of a condensing unit because the condensate can damage the painted coating.

**NOTE** - If winter design temperature is below 32°F (0°C), exhaust piping should be insulated with 1/2" (13mm), Armaflex or equivalent when run through unheated space. Do not leave any surface area of exhaust pipe open to outside air; exterior exhaust pipe should be insulated with 1/2" (13mm) Armaflex or equivalent. In extreme cold climate areas, 3/4" (19mm) Armaflex or equivalent may be necessary. Insulation on outside runs of exhaust pipe must be painted or wrapped to protect insulation from deterioration. Exhaust pipe insulation may not be necessary in some specific applications.

**NOTE** - During extremely cold temperatures, below approximately 20°F (6.7°C), units with long runs of vent pipe through unconditioned space, even when insulated, may form ice in the exhaust termination that prevents the unit from operating properly. Longer run times of at least 5 minutes will alleviate most icing problems. Also, a heating cable may be installed on exhaust piping and termination to prevent freeze-ups. Heating cable installation kit is available from Lennox. See Condensate Piping section for part numbers.

### **IMPORTANT**

**Do not use screens or perforated metal in exhaust terminations. Doing so will cause freeze-ups and may block the terminations.**

### **IMPORTANT**

**For Canadian Installations Only:**  
**In accordance to CSA International B149 installation codes, the minimum allowed distance between the combustion air intake inlet and the exhaust outlet of other appliances shall not be less than 12 inches (305mm).**

## VENT TERMINATION CLEARANCES FOR NON-DIRECT VENT INSTALLATIONS IN THE USA AND CANADA

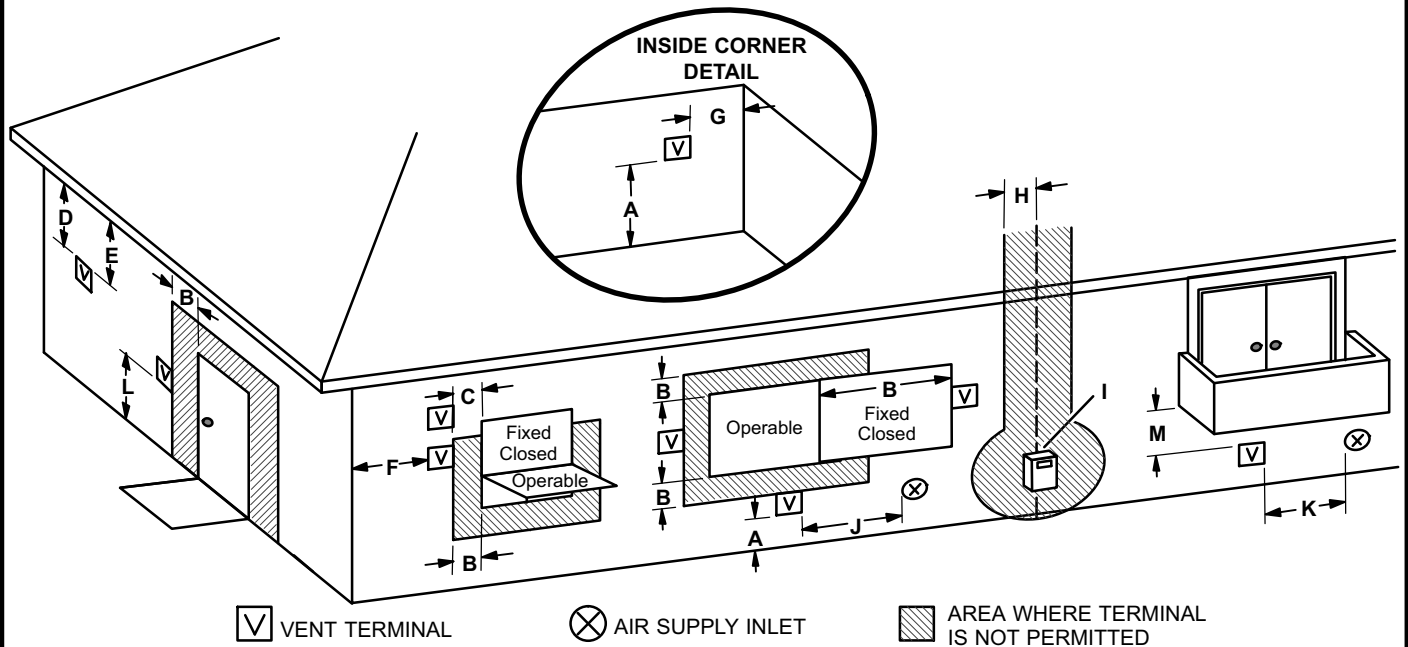

	US Installations <sup>1</sup>	Canadian Installations <sup>2</sup>	
A =	Clearance above grade, veranda, porch, deck or balcony	12 inches (305mm) or 12 in. 305mm above average snow accumulation.	12 inches (305mm) or 12 in. 305mm above average snow accumulation.
B =	Clearance to window or door that may be opened	4 feet (1.2 m) below or to side of opening; 1 foot (30 cm) above opening	6 inches (152mm) for appliances <10,000 Btuh (3kw), 12 inches (305mm) for appliances > 10,000 Btuh (3kw) and <100,000 Btuh (30kw), 36 inches (.9m) for appliances > 100,000 Btuh (30kw)
C =	Clearance to permanently closed window	* 12"	* 12"
D =	Vertical clearance to ventilated soffit located above the terminal within a horizontal distance of 2 feet (mm) from the center line of the terminal	* Equal to or greater than soffit depth.	* Equal to or greater than soffit depth.
E =	Clearance to unventilated soffit	* Equal to or greater than soffit depth.	* Equal to or greater than soffit depth.
F =	Clearance to outside corner	* No minimum to outside corner	* No minimum to outside corner
G =	Clearance to inside corner	* 3 feet (.9m)	* 3 feet (.9m)
H =	Clearance to each side of center line extended above meter / regulator assembly	* 3 feet (.9m) within a height 15 feet (4.5m) above the meter / regulator assembly	3 feet (.9m) within a height 15 feet (4.5m) above the meter / regulator assembly
I =	Clearance to service regulator vent outlet	* 3 feet (.9m)	3 feet (.9m)
J =	Clearance to non-mechanical air supply inlet to building or the combustion air inlet to any other appliance	4 feet (1.2 m) below or to side of opening; 1 foot (30 cm) above opening	6 inches (152mm) for appliances <10,000 Btuh (3kw), 12 inches (305mm) for appliances > 10,000 Btuh (3kw) and <100,000 Btuh (30kw), 36 inches (.9m) for appliances > 100,000 Btuh (30kw)
K =	Clearance to mechanical air supply inlet	3 feet (.9m) above if within 10 feet (3m) horizontally	6 feet (1.8m)
L =	Clearance above paved sidewalk or paved driveway located on public property	7 feet (2.1m)†	7 feet (2.1m)†
M =	Clearance under veranda, porch, deck or balcony	*12 inches (305mm)‡	12 inches (305mm)‡

<sup>1</sup> In accordance with the current ANSI Z223.1/NFPA 54 Natural Fuel Gas Code

<sup>2</sup> In accordance with the current CSA B149.1, Natural Gas and Propane Installation Code

† A vent shall not terminate directly above a sidewalk or paved driveway that is located between two single family dwellings and serves both dwellings.

‡ Permitted only if veranda, porch, deck or balcony is fully open on a minimum of two sides beneath the floor. Lennox recommends avoiding this location if possible.

\*For clearances not specified in ANSI Z223.1/NFPA 54 or CSA B149.1, clearance will be in accordance with local installation codes and the requirements of the gas supplier and these installation instructions."

**FIGURE 18**

## VENT TERMINATION CLEARANCES FOR DIRECT VENT INSTALLATIONS IN THE USA AND CANADA

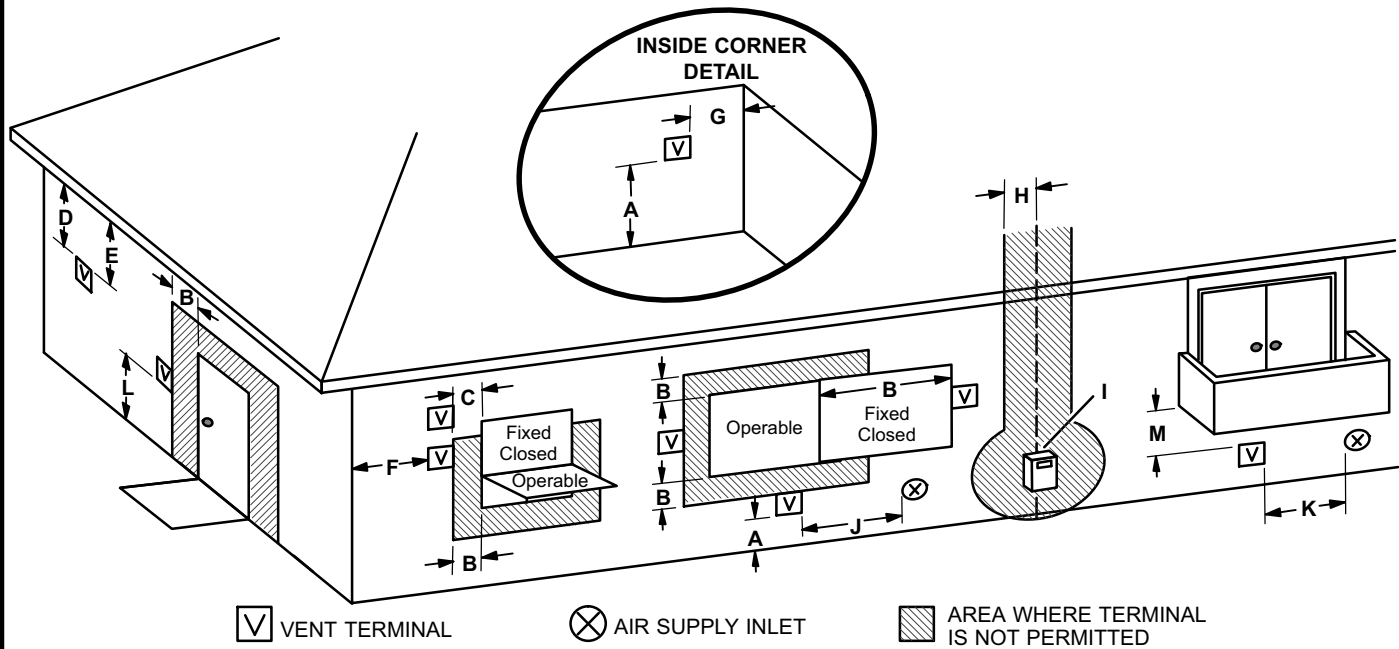

	US Installations <sup>1</sup>	Canadian Installations <sup>2</sup>	
A =	Clearance above grade, veranda, porch, deck or balcony	12 inches (305mm) or 12 in. 305mm above average snow accumulation.	12 inches (305mm) or 12 in. 305mm above average snow accumulation.
B =	Clearance to window or door that may be opened	6 inches (152mm) for appliances <10,000 Btuh (3kw), 9 inches (mm) for appliances > 10,000 Btuh (3kw) and <50,000 Btuh (15 kw), 12 inches (305mm) for appliances > 50,000 Btuh (15kw)	6 inches (152mm) for appliances <10,000 Btuh (3kw), 12 inches (305mm) for appliances > 10,000 Btuh (3kw) and <100,000 Btuh (30kw), 36 inches (.9m) for appliances > 100,000 Btuh (30kw)
C =	Clearance to permanently closed window	* 12"	* 12"
D =	Vertical clearance to ventilated soffit located above the terminal within a horizontal distance of 2 feet (mm) from the center line of the terminal	* Equal to or greater than soffit depth	* Equal to or greater than soffit depth
E =	Clearance to unventilated soffit	* Equal to or greater than soffit depth	* Equal to or greater than soffit depth
F =	Clearance to outside corner	* No minimum to outside corner	* No minimum to outside corner
G =	Clearance to inside corner	* 3 feet (.9m)	* 3 feet (.9m)
H =	Clearance to each side of center line extended above meter / regulator assembly	3 feet (.9m) within a height 15 feet (4.5m) above the meter / regulator assembly	3 feet (.9m) within a height 15 feet (4.5m) above the meter / regulator assembly
I =	Clearance to service regulator vent outlet	* 3 feet (.9m)	3 feet (.9m)
J =	Clearance to non-mechanical air supply inlet to building or the combustion air inlet to any other appliance	6 inches (152mm) for appliances <10,000 Btuh (3kw), 9 inches (mm) for appliances > 10,000 Btuh (3kw) and <50,000 Btuh (15 kw), 12 inches (305mm) for appliances > 50,000 Btuh (15kw)	6 inches (152mm) for appliances <10,000 Btuh (3kw), 12 inches (305mm) for appliances > 10,000 Btuh (3kw) and <100,000 Btuh (30kw), 36 inches (.9m) for appliances > 100,000 Btuh (30kw)
K =	Clearance to mechanical air supply inlet	3 feet (.9m) above if within 10 feet (3m) horizontally	6 feet (1.8m)
L =	Clearance above paved sidewalk or paved driveway located on public property	* 7 feet (2.1m)	7 feet (2.1m)†
M =	Clearance under veranda, porch, deck or balcony	*12 inches (305mm)‡	12 inches (305mm)‡

<sup>1</sup> In accordance with the current ANSI Z223.1/NFPA 54 Natural Fuel Gas Code

<sup>2</sup> In accordance with the current CSA B149.1, Natural Gas and Propane Installation Code

† A vent shall not terminate directly above a sidewalk or paved driveway that is located between two single family dwellings and serves both dwellings.

‡ Permitted only if veranda, porch, deck or balcony is fully open on a minimum of two sides beneath the floor. Lennox recommends avoiding this location if possible.

\*For clearances not specified in ANSI Z223.1/NFPA 54 or CSA B149.1, clearance will be in accordance with local installation codes and the requirements of the gas supplier and these installation instructions."

**FIGURE 19**

**Details of Intake and Exhaust Piping Terminations for Direct Vent Installations (Figure 19)**

**NOTE** - In Direct Vent installations, combustion air is taken from outdoors and flue gases are discharged to outdoors.

Intake and exhaust pipes may be routed either horizontally through an outside wall or vertically through the roof. In attic or closet installations, vertical termination through the roof is preferred. Figures 20 through 28 show typical terminations.

- 1 - Exhaust and intake exits must be in same pressure zone. Do not exit one through the roof and one on the side. Also, do not exit the intake on one side and the exhaust on another side of the house or structure.
- 2 - Intake and exhaust pipes should be placed as close together as possible at termination end (refer to illustrations). Maximum separation is 3" (76mm) on roof terminations and 6" (152mm) on side wall terminations.
- 3 - On roof terminations, the intake piping should terminate straight down using two 90° elbows (See figure 20).
- 4 - Exhaust piping must terminate straight out or up as shown. In rooftop applications, a reducer may be required on the exhaust piping at the point where it exits the structure to improve the velocity of exhaust away from the intake piping. See table 6.

**NOTE** - Care must be taken to avoid recirculation of exhaust back into intake pipe.

**TABLE 6**

**EXHAUST PIPE TERMINATION SIZE REDUCTION**

G43UF MODEL	Exhaust Pipe Size	Termination Pipe Size
045 and 070	2", 2-1/2", 3" or 4"	1-1/2"
090	2", 2-1/2", 3" or 4"	2"
110	2", 2-1/2", 3" or 4"	*2"
135	3" or 4"	*2"

\*Approved 3" concentric termination kit terminates with 2-5/8" ID pipe.

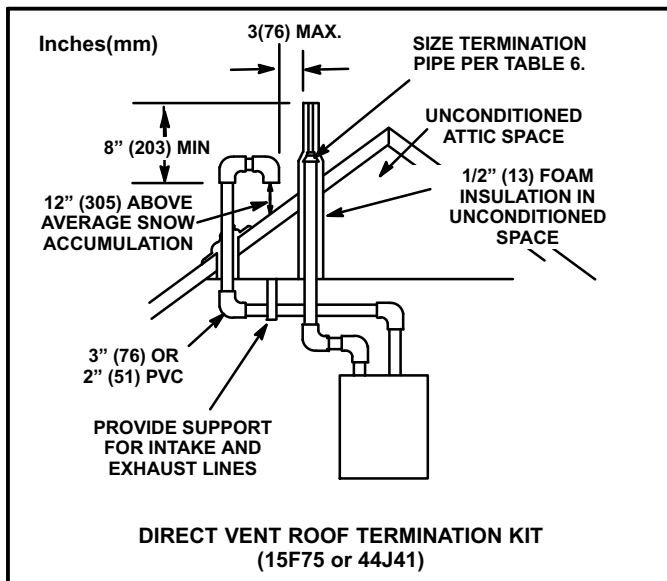

**FIGURE 20**

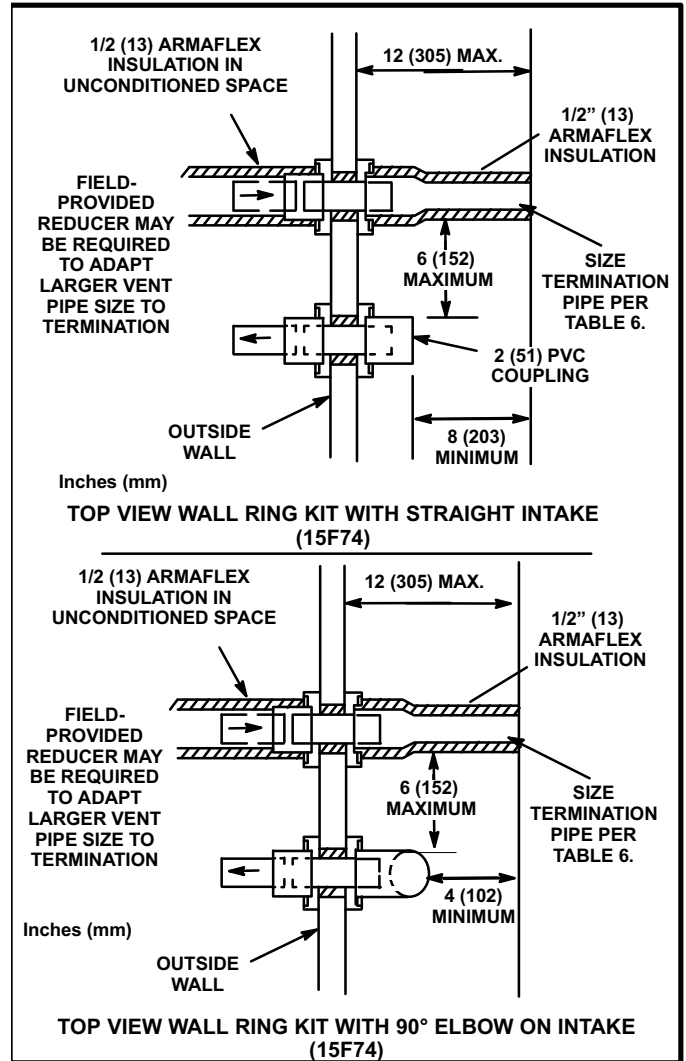

**FIGURE 21**

- 5 - On field supplied terminations for side wall exits, exhaust piping should extend a maximum of 12 inches (305mm) beyond the outside wall. Intake piping should be as short as possible. See figure 21.
- 6 - On field supplied terminations, a minimum separation distance between the end of the exhaust pipe and the end of the intake pipe is 8 inches (203mm).
- 7 - If intake and exhaust piping must be run up a side wall to position above snow accumulation or other obstructions, piping must be supported every 3 ft. (.9m) as shown in figure 13. Refer to figure 24 for proper piping method. In addition, WTK wall termination kit must be extended for use in this application. See figure 27. When exhaust and intake piping must be run up an outside wall, the exhaust piping must be terminated with pipe sized per table 6. The intake piping may be equipped with a 90° elbow turndown. Using turndown will add 5 feet (1.5m) to the equivalent length of the pipe.
- 8 - Based on the recommendation of the manufacturer, a multiple furnace installation may use a group of up to four termination kits WTK assembled together horizontally, as shown in figure 26.

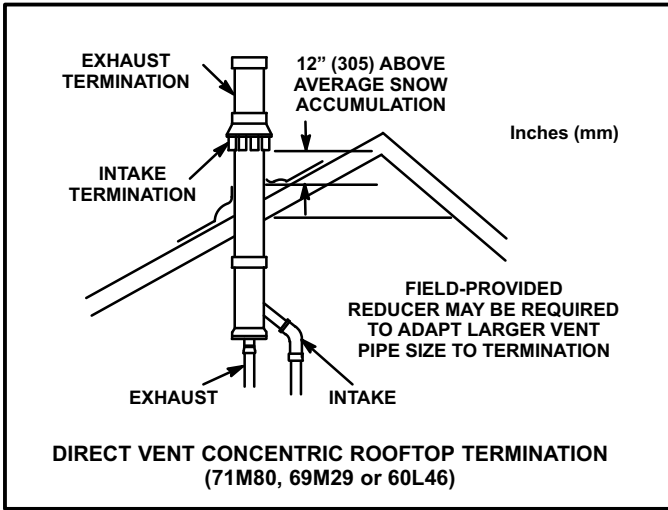

FIGURE 22

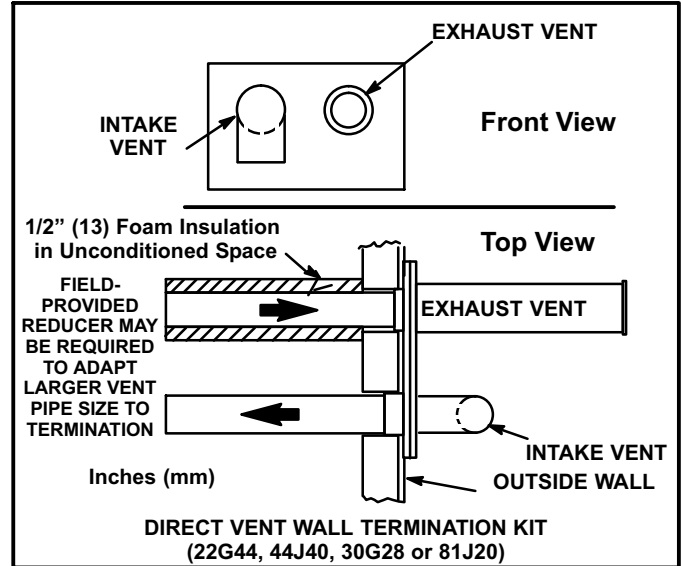

FIGURE 25

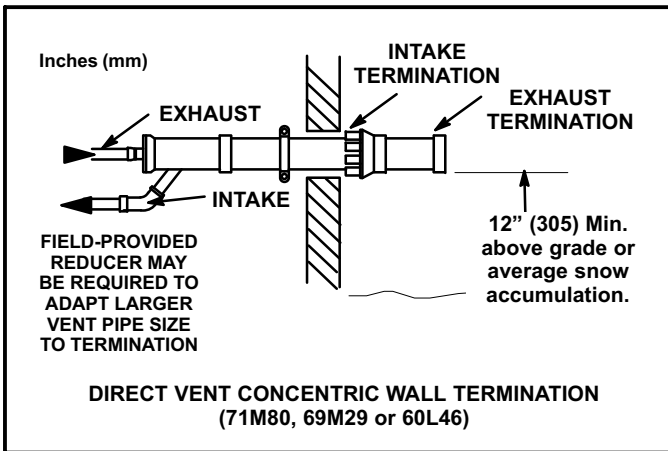

FIGURE 23

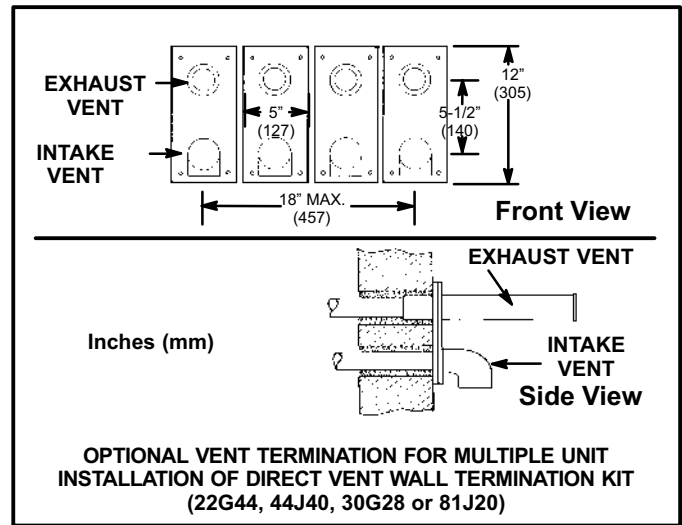

FIGURE 26

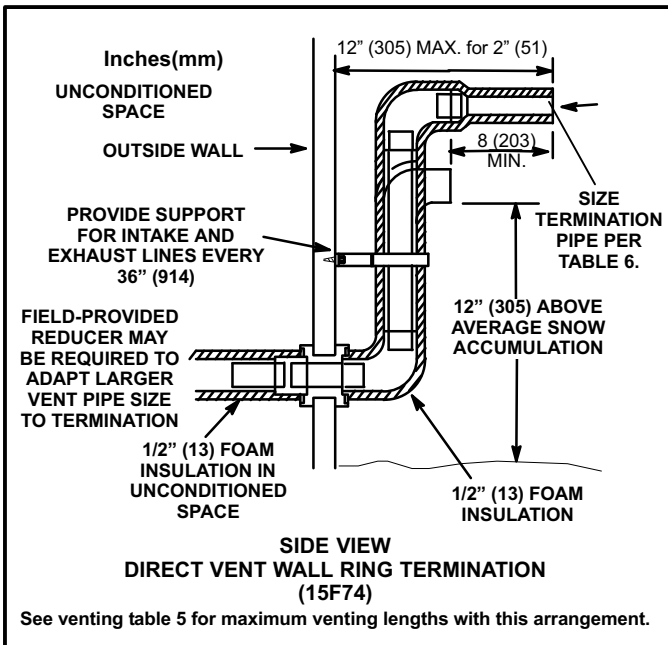
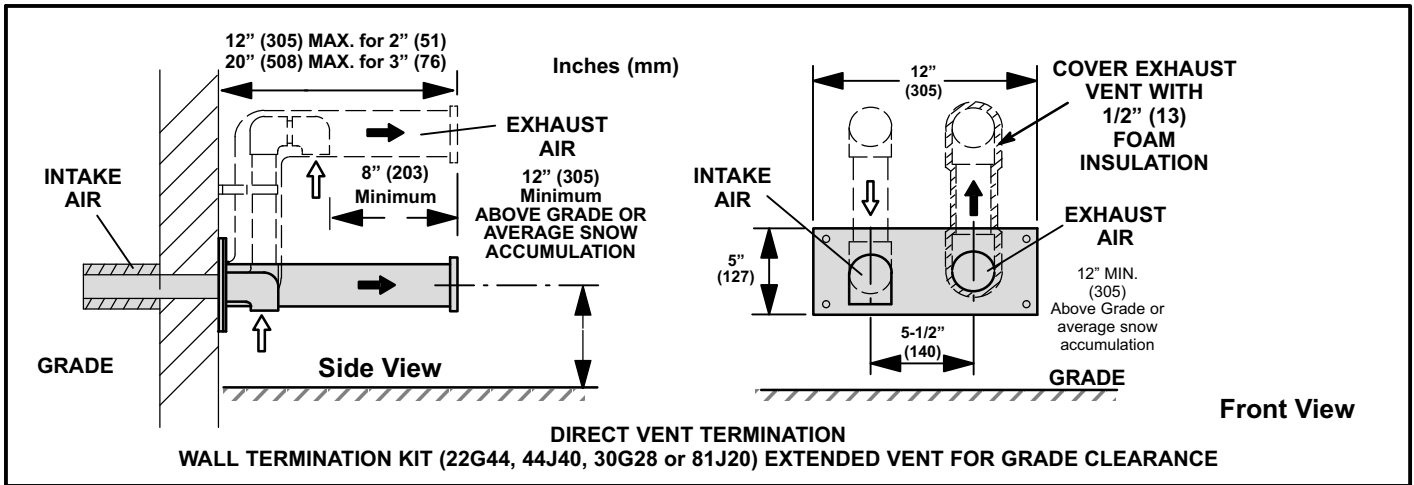
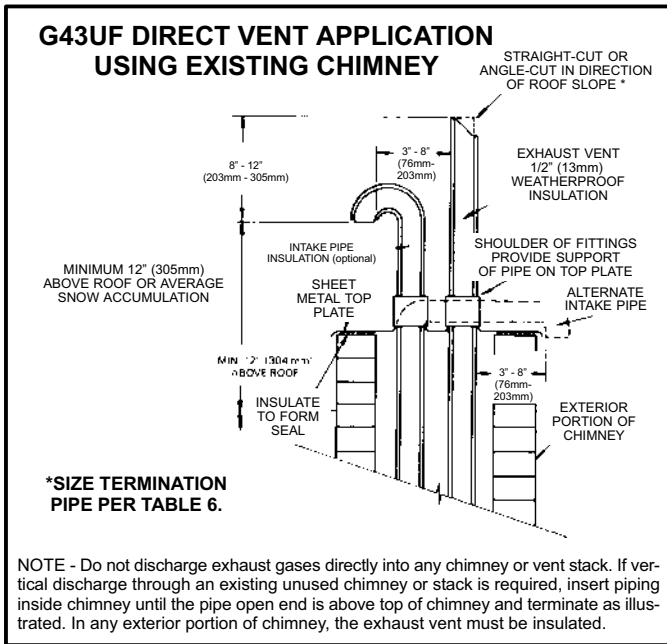

FIGURE 24



**FIGURE 27**

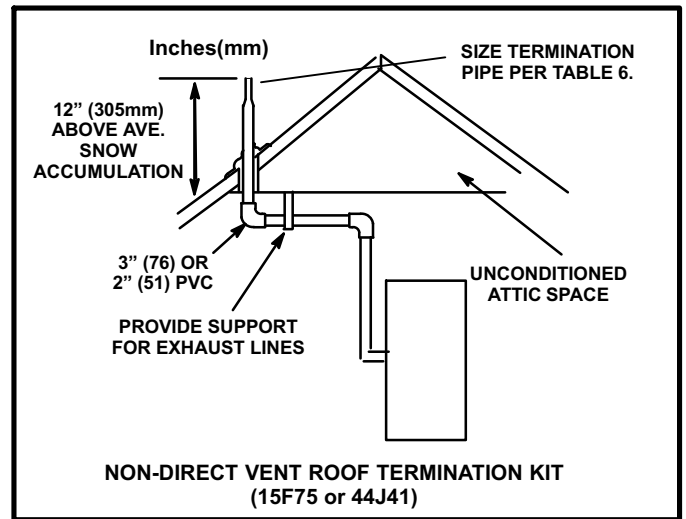

**FIGURE 28**

**Details of Exhaust Piping Terminations for Non-Direct Vent Applications**

Exhaust pipes may be routed either horizontally through an outside wall or vertically through the roof. In attic or closet installations, vertical termination through the roof is preferred. Figures 29 through 32 show typical terminations.

- 1 - Exhaust piping must terminate straight out or up as shown. The termination pipe must be sized as listed in table 6. The specified pipe size ensures proper velocity required to move the exhaust gases away from the building.
- 2 - On field supplied terminations for side wall exits, exhaust piping should extend a maximum of 12 inches (305mm) beyond the outside wall. See figure 30.



**FIGURE 29**

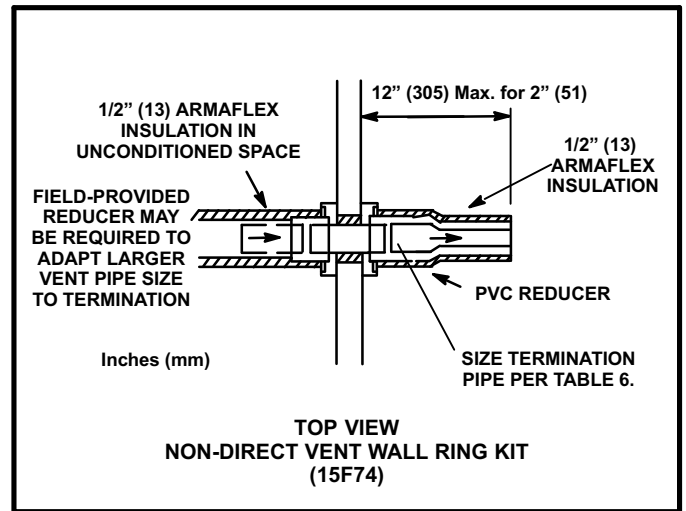

**FIGURE 30**

3 - If exhaust piping must be run up a side wall to position above snow accumulation or other obstructions, piping must be supported every 3 feet (.9m) as shown in figure 13. Refer to figure 31 for proper piping method. When exhaust piping must be run up an outside wall, any reduction in exhaust pipe size must be done after the final elbow.

When possible, the condensate drain lines should be routed within the conditioned space to avoid freezing of condensate and blockage of the drain line. When condensate drain line must be routed through unconditioned space, use an electric heat cable to prevent freezing of condensate.

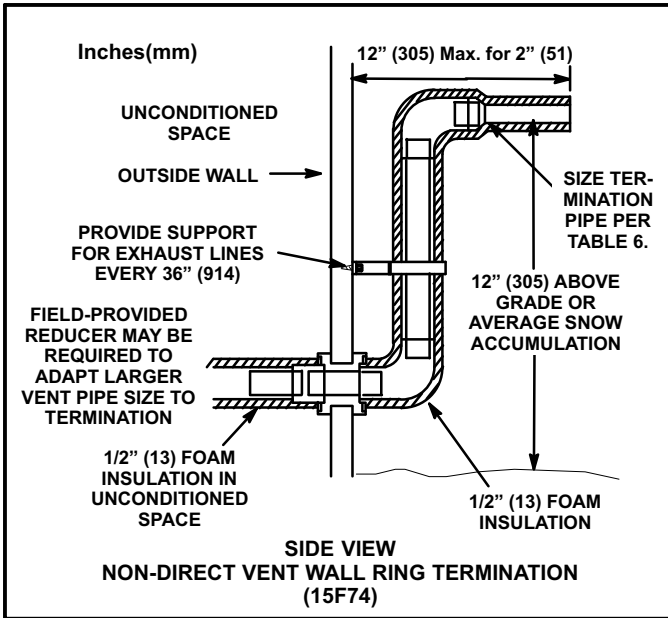

FIGURE 31

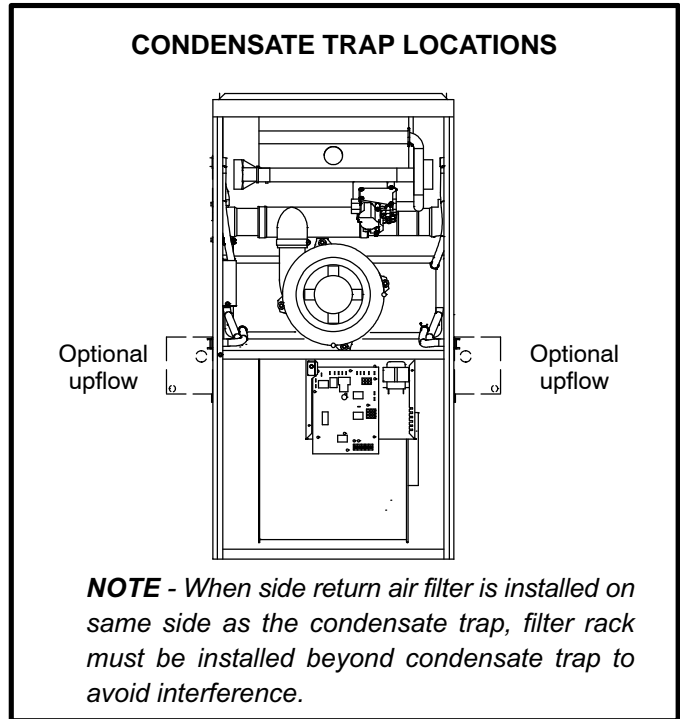

FIGURE 33

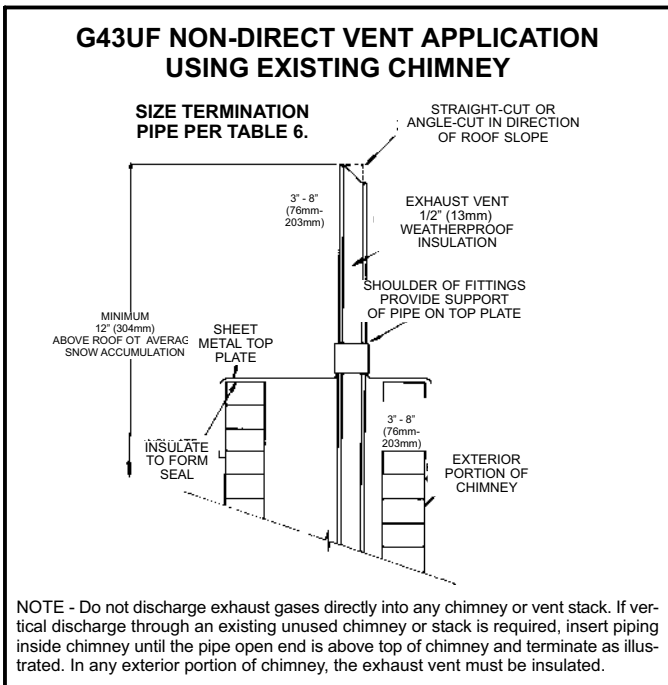

FIGURE 32

1 - Determine which side condensate piping will exit the unit. Remove plugs from the condensate collar at the appropriate location on the side of the unit.

**NOTE** - The condensate trap is factory-shipped with two rubber O-rings and two rubber clean-out caps installed. Check to make sure that these items are in place before installing the trap assembly. O-rings must be properly positioned between trap and cabinet to ensure seal between the condensate trap and the cabinet. It is not necessary to apply glue or sealant.

2 - Install condensate trap onto the condensate collar. Use provided HI/LO screws to secure two upper flanges of the trap to the collar. Use provided sheet metal screw to secure bottom trap flange to side of unit. **DO NOT apply glue to secure condensate trap to cabinet.** All other joints must be glued. See figure 34.

**NOTE** - Condensate trap must be installed on the same side as exhaust piping.

### Condensate Piping

This unit is designed for either right- or left-side exit of condensate piping; however, it must be installed on the same side of the unit as the exhaust piping. A 5-1/2" service clearance is required for the condensate trap. Refer to figure 33 for condensate trap locations.

## CAUTION

**DO NOT use a power driver to tighten screws which secure condensate trap to cabinet. Screws should be hand-tightened using a screw driver to avoid the possibility of damage to the trap assembly.**



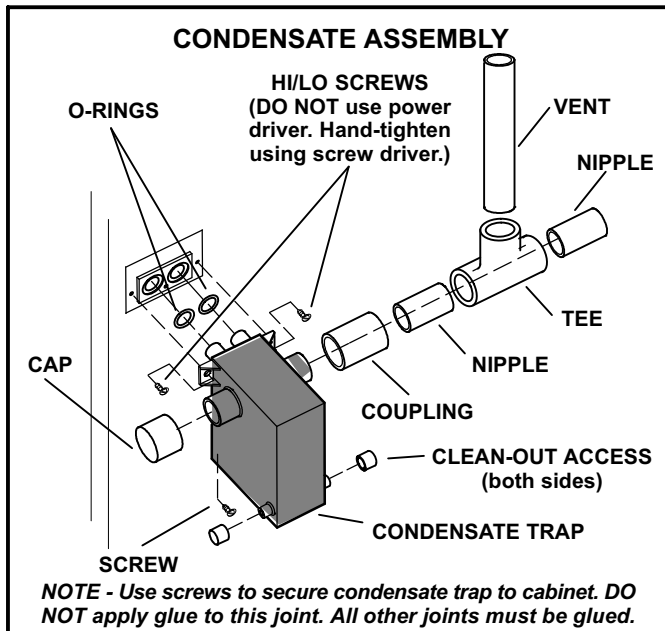

**FIGURE 34**

- 3 - The condensate trap provided with the unit is manufactured using ABS material. Use ABS to PVC transition solvent cement to glue a field-provided PVC coupling or PVC pipe to the trap. Install a tee and vent pipe near the trap.

**NOTE** - The condensate trap drain stubs (both sides) have an outer diameter which will accept a standard 3/4" PVC coupling. The inner diameter of each stub will accept standard 1/2" diameter PVC pipe.

**NOTE** - Vinyl tubing may be used for condensate drain. Tubing must be 1-1/4" OD X 1" ID and should be attached to the drain stubs on the trap using a hose clamp.

- 4 - Glue the field-provided drain line to the tee. Route the drain line to an open drain. As an alternate, clear vinyl tubing may be used to drain condensate away from the trap. Secure the vinyl tubing to the drain stubs on the trap using a hose clamp. Do not overtighten the hose clamp.

Condensate line must be sloped downward away from condensate trap to drain. If drain level is above condensate trap, condensate pump must be used. Condensate drain line should be routed within the conditioned space to avoid freezing of condensate and blockage of drain line. If this is not possible, a heat cable kit may be used on the condensate trap and line. Heating cable kit is available from Lennox in various lengths; 6 ft. (1.8m) - kit no. 26K68; 24 ft. (7.3m) - kit no. 26K69; and 50 ft. (15.2m) - kit no. 26K70.

## ⚠ CAUTION

**Do not use copper tubing or existing copper condensate lines for drain line.**

- 5 - If unit will be started immediately upon completion of installation, prime trap per procedure outlined in Unit Start-Up section.
- 6 - Glue the provided cap onto the unused condensate drain line stub.

## Gas Piping

## ⚠ CAUTION

**If a flexible gas connector is required or allowed by the authority that has jurisdiction, black iron pipe shall be installed at the gas valve and extend outside the furnace cabinet.**

## ⚠ WARNING

**Do not exceed 600 in-lbs (50 ft-lbs) torque when attaching the gas piping to the gas valve.**

- 1 - Gas piping may be routed into the unit through either the left- or right-hand side. Supply piping enters into the gas valve from the side of the valve as shown in figure 36.

## ⚠ IMPORTANT

**The Honeywell VR8205 gas valve requires a low inlet pressure switch in LP/propane applications. A 4" BIP nipple must be installed in the gas valve inlet when right-side gas entry is used in LP/propane applications. See figure 36.**

- 2 - When connecting gas supply, factors such as length of run, number of fittings and furnace rating must be considered to avoid excessive pressure drop. Table 7 lists recommended pipe sizes for typical applications.

**NOTE** - Use two wrenches when connecting gas piping to avoid transferring torque to the manifold.

- 3 - Gas piping must not run in or through air ducts, clothes chutes, chimneys or gas vents, dumb waiters or elevator shafts. Center gas line through piping hole. Gas line should not touch side of unit. See figure 36.

- 4 - Piping should be sloped 1/4 inch per 15 feet (6mm per 5.6m) upward toward the gas meter from the furnace. The piping must be supported at proper intervals, every 8 to 10 feet (2.44 to 3.05m), using suitable hangers or straps. Install a drip leg in vertical pipe runs to serve as a trap for sediment or condensate.
- 5 - A 1/8" N.P.T. plugged tap or pressure post is located on the gas valve to facilitate test gauge connection. See figures 43 and 44.
- 6 - In some localities, codes may require installation of a manual main shut-off valve and union (furnished by installer) external to the unit. Union must be of the ground joint type.

**Leak Check**

After gas piping is completed, carefully check all piping connections (factory- and field-installed) for gas leaks. Use a leak detecting solution or other preferred means. *The furnace must be isolated from the gas supply system by closing its individual manual shut-off valve during any pressure testing of the gas supply system at pressures less than or equal to 1/2 psig (3.48 kPa, 14 inches w.c.).*

**⚠ IMPORTANT**

**When testing pressure of gas lines, gas valve must be disconnected and isolated. See figure 35. Gas valves can be damaged if subjected to pressures greater than 1/2 psig (3.48 kPa).**

**⚠ WARNING**

**FIRE OR EXPLOSION HAZARD**  
 Failure to follow the safety warnings exactly could result in serious injury, death, or property damage. Never use an open flame to test for gas leaks. Check all connections using a commercially available soap solution made specifically for leak detection. Some soaps used for leak detection are corrosive to certain metals. Carefully rinse piping thoroughly after leak test has been completed.

**⚠ IMPORTANT**

**Compounds used on threaded joints of gas piping must be resistant to the actions of liquified petroleum gases.**

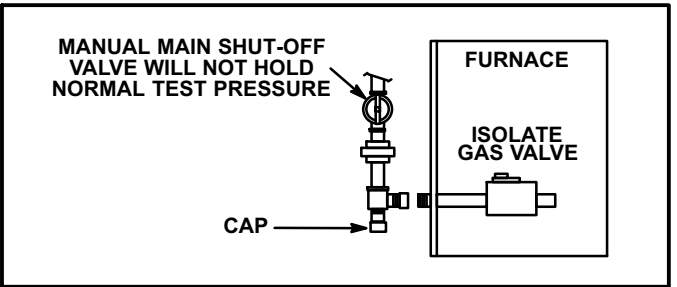

**FIGURE 35**

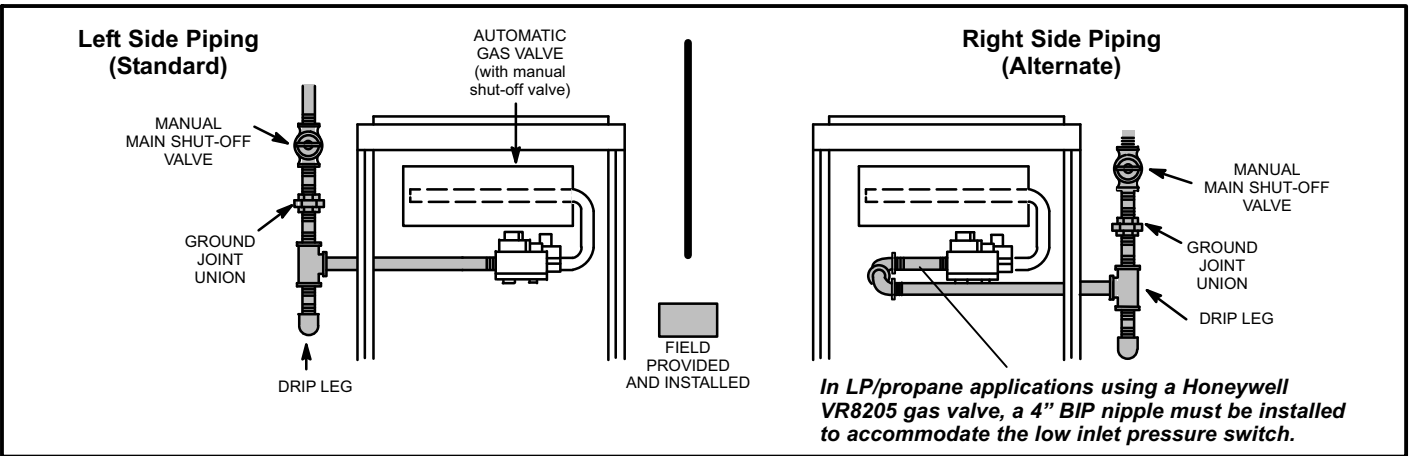

**FIGURE 36**

**TABLE 7  
GAS PIPE CAPACITY - FT<sup>3</sup>/HR (kL/HR)**

Nominal Iron Pipe Size -Inches(mm)	Internal Diameter -Inches(mm)	Length of Pipe-Feet(m)									
		10 (3.048)	20 (6.096)	30 (9.144)	40 (12.192)	50 (15.240)	60 (18.288)	70 (21.336)	80 (24.384)	90 (27.432)	100 (30.480)
1/4 (6.35)	.364 (9.246)	43 (1.13)	29 (.82)	24 (.68)	20 (.57)	18 (.51)	16 (.45)	15 (.42)	14 (.40)	13 (.37)	12 (.34)
3/8 (9.53)	.493 (12.522)	95 (2.69)	65 (1.84)	52 (1.47)	45 (1.27)	40 (1.13)	36 (1.02)	33 (.73)	31 (.88)	29 (.82)	27 (.76)
1/2 (12.7)	.622 (17.799)	175 (4.96)	120 (3.40)	97 (2.75)	82 (2.32)	73 (2.07)	66 (1.87)	61 (1.73)	57 (1.61)	53 (1.50)	50 (1.42)
3/4 (19.05)	.824 (20.930)	360 (10.19)	250 (7.08)	200 (5.66)	170 (4.81)	151 (4.28)	138 (3.91)	125 (3.54)	118 (3.34)	110 (3.11)	103 (2.92)
1 (25.4)	1.049 (26.645)	680 (19.25)	465 (13.17)	375 (10.62)	320 (9.06)	285 (8.07)	260 (7.36)	240 (6.80)	220 (6.23)	205 (5.80)	195 (5.52)
1-1/4 (31.75)	1.380 (35.052)	1400 (39.64)	950 (26.90)	770 (21.80)	660 (18.69)	580 (16.42)	530 (15.01)	490 (13.87)	460 (13.03)	430 (12.18)	400 (11.33)
1-1/2 (38.1)	1.610 (40.894)	2100 (59.46)	460 (41.34)	1180 (33.41)	990 (28.03)	900 (25.48)	810 (22.94)	750 (21.24)	690 (19.54)	650 (18.41)	620 (17.56)
2 (50.8)	2.067 (52.502)	3950 (111.85)	2750 (77.87)	2200 (62.30)	1900 (53.80)	1680 (47.57)	1520 (43.04)	1400 (39.64)	1300 (36.81)	1220 (34.55)	1150 (32.56)
2-1/2 (63.5)	2.469 (67.713)	6300 (178.39)	4350 (123.17)	3520 (99.67)	3000 (84.95)	2650 (75.04)	2400 (67.96)	2250 (63.71)	2050 (58.05)	1950 (55.22)	1850 (52.38)
3 (76.2)	3.068 (77.927)	11000 (311.48)	7700 (218.03)	6250 (176.98)	5300 (150.07)	4750 (134.50)	4300 (121.76)	3900 (110.43)	3700 (104.77)	3450 (97.69)	3250 (92.03)
4 (101.6)	4.026 (102.260)	23000 (651.27)	15800 (447.39)	12800 (362.44)	10900 (308.64)	9700 (274.67)	8800 (249.18)	8100 (229.36)	7500 (212.37)	7200 (203.88)	6700 (189.72)

**NOTE** - Capacity given in cubic feet of gas per hour (kilo liters of gas per hour) and based on 0.60 specific gravity gas.

## Electrical

### ELECTROSTATIC DISCHARGE (ESD) Precautions and Procedures

## ⚠ CAUTION

Electrostatic discharge can affect electronic components. Take precautions during furnace installation and service to protect the furnace's electronic controls. Precautions will help to avoid control exposure to electrostatic discharge by putting the furnace, the control and the technician at the same electrostatic potential. Neutralize electrostatic charge by touching hand and all tools on an unpainted unit surface, such as the gas valve or blower deck, before performing any service procedure.

The unit is equipped with a field make-up box. The make-up box may be moved to the right side of the furnace to facilitate installation. If the make-up box is moved to the right side, the excess wire must be pulled into the blower compartment. Secure the excess wire to the existing harness to protect it from damage.

Refer to figure 40 for field wiring and figure 41 for schematic wiring diagram and troubleshooting.

Select circuit protection and wire size according to the unit nameplate. The power supply wiring must meet Class I restrictions.

Holes are on both sides of the furnace cabinet to facilitate wiring.

Install a separate disconnect switch (protected by either fuse or circuit breaker) near the furnace so that power can be turned off for servicing.

Before connecting the thermostat or the power wiring, check to make sure the wires will be long enough for servicing at a later date. Remove the blower access panel to check the length of the wire.

Complete the wiring connections to the equipment. Use the provided unit wiring diagram and the field wiring diagram shown in figure 40. Use 18-gauge wire or larger that is suitable for Class II rating for thermostat connections.

Electrically ground the unit according to local codes or, in the absence of local codes, according to the current National Electric Code (ANSI/NFPA No. 70) for the USA and current Canadian Electric Code part 1 (CSA standard C22.1) for Canada. A green ground wire is provided in the field make-up box.

**NOTE** - The G43UF furnace contains electronic components that are polarity sensitive. Make sure that the furnace is wired correctly and is properly grounded.

One line voltage "EAC" accessory terminal is provided on the furnace control board. Any electronic air cleaner rated up to one amp can be connected to this terminal with the neutral leg of the circuit being connected to any of the "NEUTRAL" terminals. See figure 42 for control board configuration. This terminal is energized whenever the blower is operating.

One line voltage "HUM" accessory terminal is provided on the furnace control board. Any humidifier rated up to one amp can be connected to this terminal with the neutral leg of the circuit being connected to any of the "NEUTRAL" terminals. See figure 42 for control board configuration. This terminal is energized in the heating mode whenever the combustion air inducer is operating.

#### INTERIOR MAKE-UP BOX INSTALLATION

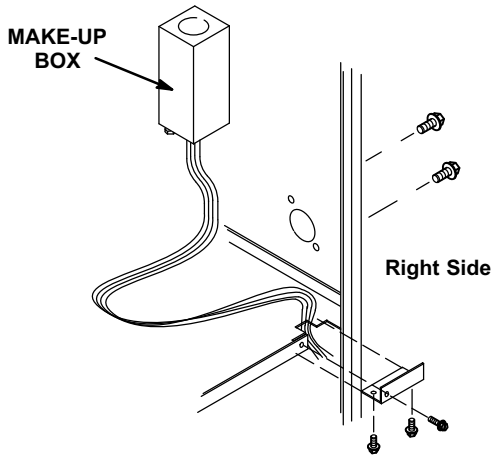

FIGURE 37

#### INTERIOR MAKE-UP BOX INSTALLATION

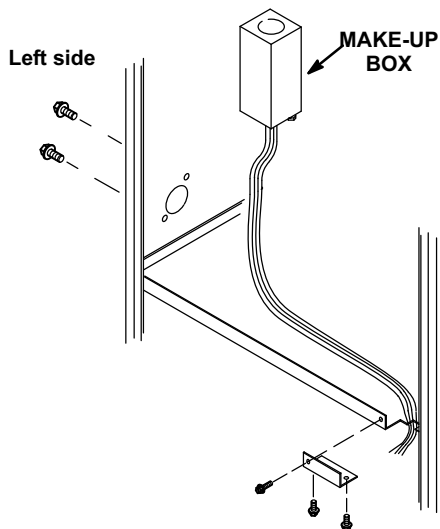
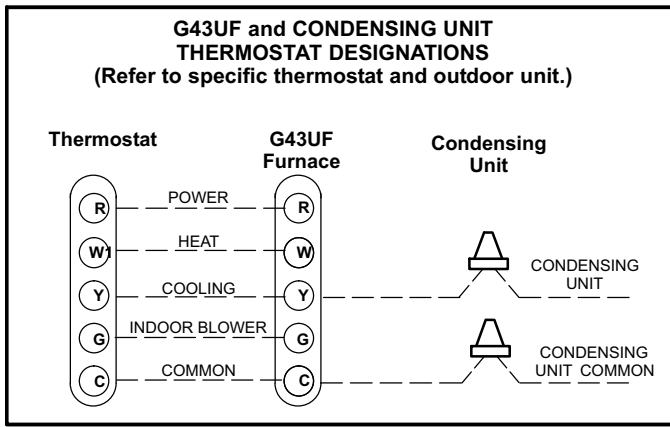

FIGURE 38

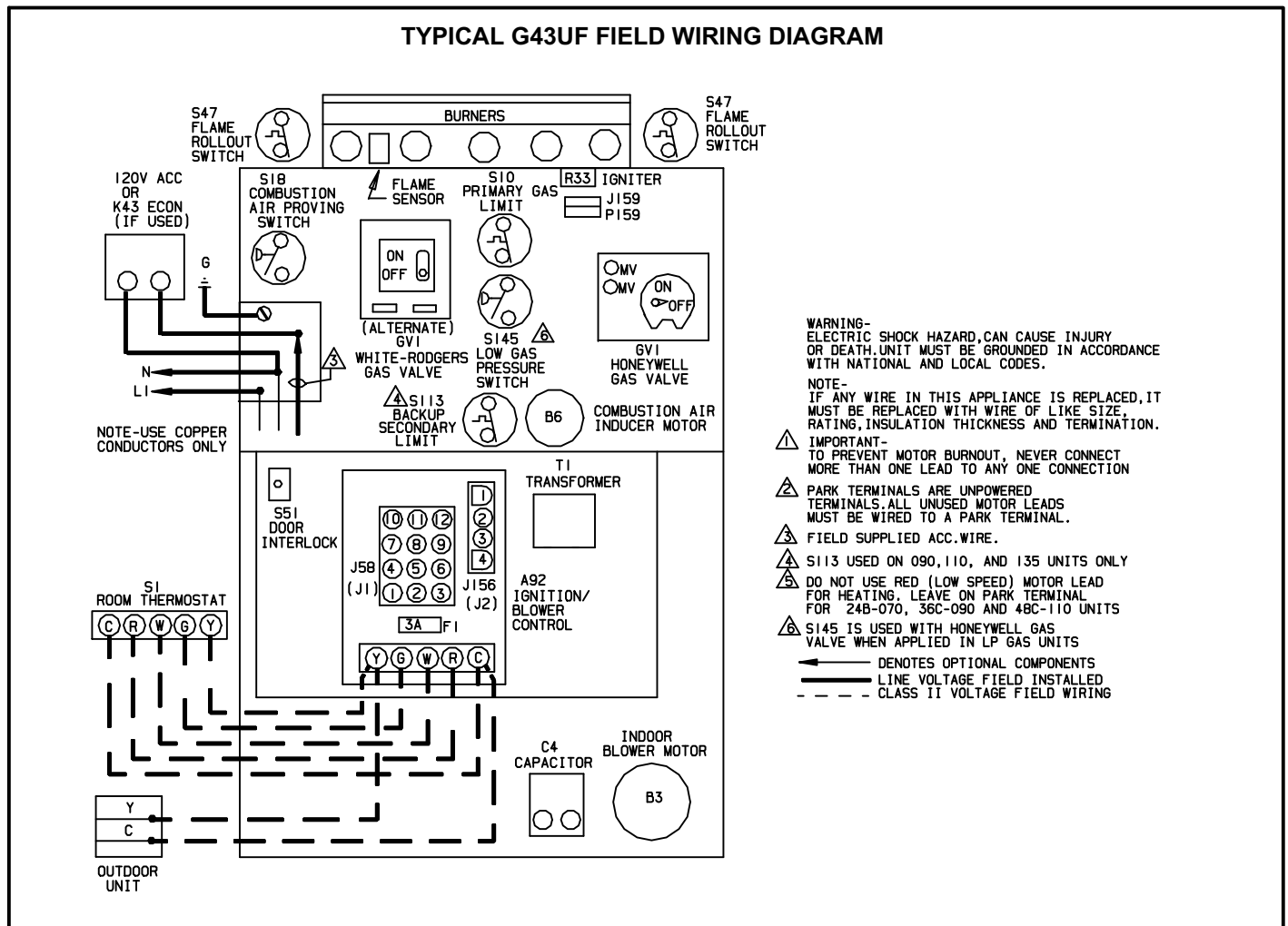

**FIGURE 39**

Install the room thermostat according to the instructions provided with the thermostat. See figure 39 for thermostat designations. If the furnace is being matched with a heat pump, refer to the FM21 installation instruction.

**Indoor Blower Speeds**

- 1 - When the thermostat is set to "FAN ON," the indoor blower will run continuously on the heating speed when there is no cooling or heating demand.
- 2 - When the G43UF is running in the heating mode, the indoor blower will run on the heating speed.
- 3 - When there is a cooling demand, the indoor blower will run on the cooling speed.



**FIGURE 40**

# TYPICAL G43UF WIRING DIAGRAM

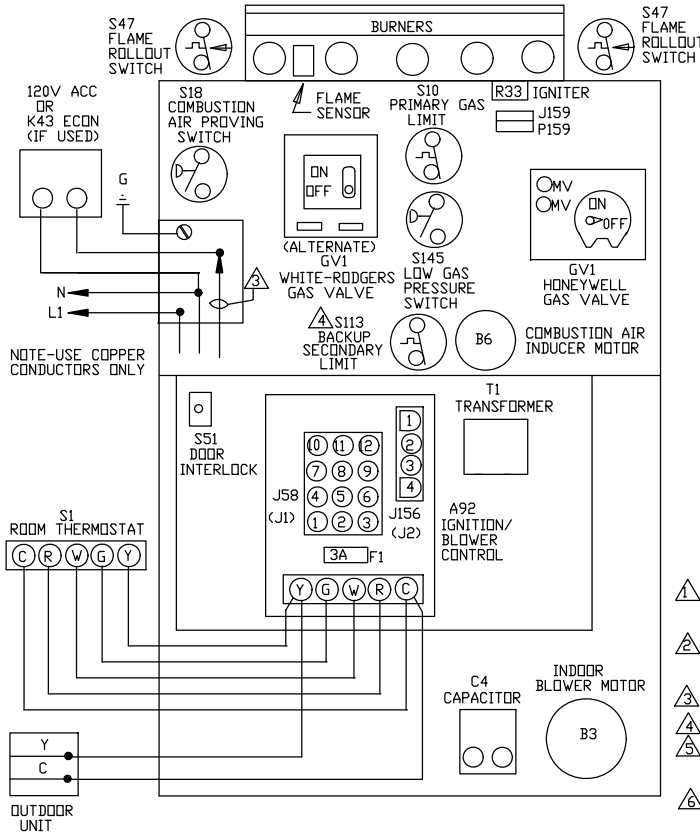

BLOWER SPEED CHART				
UNIT	FACTORY CONNECTED SPEED TAPS			MOTOR SPEEDS AVAIL.
24B-045	YELLOW	RED	BROWN	4
24B-070	BROWN	RED	YELLOW	4
36B-070	YELLOW	RED	BROWN	4
36C-090	BROWN	RED	YELLOW	4
36C-090H	YELLOW	RED	BROWN	4
48C-090	YELLOW	RED	BROWN	4
48C-110	YELLOW	RED	BROWN	4
48C-110H	YELLOW	RED	BROWN	4
60C-110	YELLOW	RED	BROWN	4
60D-135	YELLOW	RED	BROWN	4

BLOWER SPEED SELECTION	
HI	LO
SPEED TAPS	BLACK BROWN YELLOW RED 4
THERMOSTAT HEAT ANTICIPATION SETTINGS	
.65 AMP	HONEYWELL VALVE
.50 AMP	WHITE-RODGERS VALVE

JACKPLUG CHART	
J.P58	JACK/PLUG-BURNER CONTROL
J.P156	JACK/PLUG-INDUCER/IGNITER
J.P159	JACK/PLUG-IGNITER

WARNING-  
ELECTRIC SHOCK HAZARD. CAN CAUSE INJURY OR DEATH. UNIT MUST BE GROUNDED IN ACCORDANCE WITH NATIONAL AND LOCAL CODES.

NOTE-  
IF ANY WIRE IN THIS APPLIANCE IS REPLACED, IT MUST BE REPLACED WITH WIRE OF LIKE SIZE, RATING, INSULATION THICKNESS AND TERMINATION.

- ⚠ IMPORTANT- TO PREVENT MOTOR BURNOUT, NEVER CONNECT MORE THAN ONE LEAD TO ANY ONE CONNECTION
  - ⚠ PARK TERMINALS ARE UNPOWERED TERMINALS. ALL UNUSED MOTOR LEADS MUST BE WIRED TO A PARK TERMINAL.
  - ⚠ FIELD SUPPLIED ACC. WIRE.
  - ⚠ S113 USED ON 090, 110, AND 135 UNITS ONLY
  - ⚠ DO NOT USE RED (LOW SPEED) MOTOR LEAD FOR HEATING. LEAVE ON PARK TERMINAL FOR 24B-070, 36C-090 AND 48C-110 UNITS
  - ⚠ S145 IS USED WITH HONEYWELL GAS VALVE WHEN APPLIED IN LP GAS UNITS
- ← DENOTES OPTIONAL COMPONENTS  
 ← LINE VOLTAGE FIELD INSTALLED  
 ← CLASS II VOLTAGE FIELD WIRING

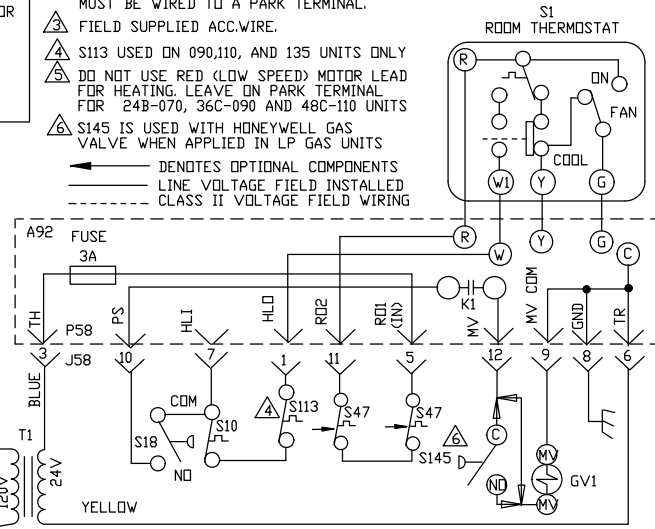
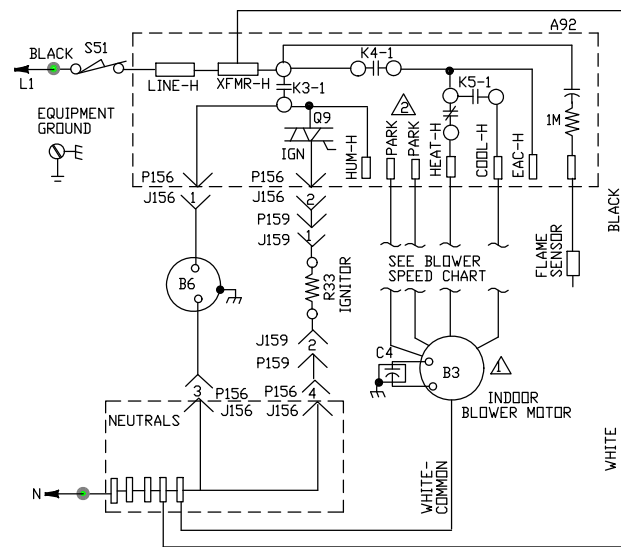
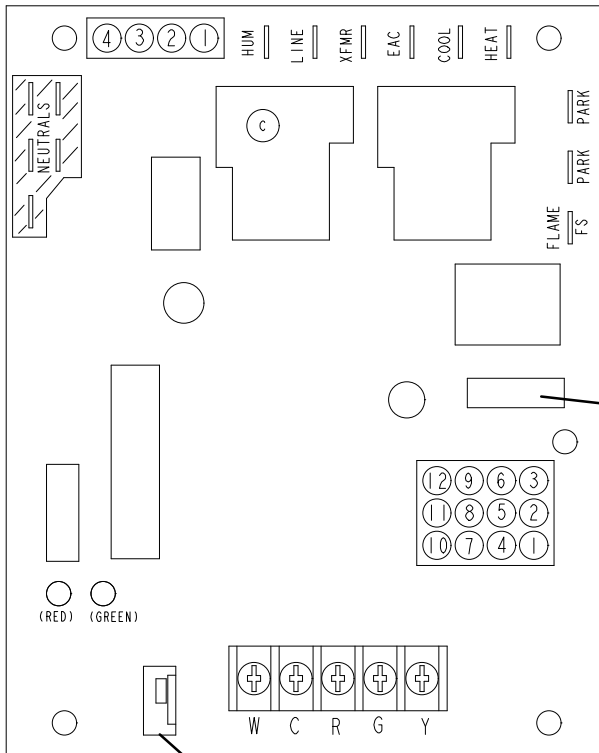

FIGURE 41

**INTEGRATED CONTROL BOARD  
(Automatic Hot Surface Ignition System)**



TERMINAL DESIGNATIONS	
HUM	Humidifier (120VAC)
LINE	Input (120VAC)
XFMR	Transformer (120VAC)
EAC	Electronic Air Cleaner (120VAC)
COOL	Blower - Cooling Speed (120VAC)
HEAT	Blower - Heating Speed (120VAC)
PARK	Dead terminals to park alternate spd taps
FLAME	Flame sensor
NEUTRALS	Neutral terminals (120VAC)

3 AMP, 32 VAC FUSE

BLOWER OFF  
DELAY JUMPER

FIGURE 42

**Unit Start-Up**

FOR YOUR SAFETY READ BEFORE OPERATING

**! WARNING**

Do not use this furnace if any part has been under-water. A flood-damaged furnace is extremely dangerous. Attempts to use the furnace can result in fire or explosion. Immediately call a qualified service technician to inspect the furnace and to replace all gas controls, control system parts, and electrical parts that have been wet or to replace the furnace, if deemed necessary.

**! WARNING**



Danger of explosion. Can cause injury or product or property damage. Should the gas supply fail to shut off or if overheating occurs, shut off the gas valve to the furnace before shutting off the electrical supply.

**! CAUTION**

Before attempting to perform any service or maintenance, turn the electrical power to unit OFF at disconnect switch.

**Priming Condensate Trap**

The condensate trap should be primed with water prior to start-up to ensure proper condensate drainage. Either pour 10 fl. oz. (300 ml) of water into the trap, or follow these steps to prime the trap:

- 1 - Follow the lighting instructions to place the unit into operation.
- 2 - Set the thermostat to initiate a heating demand.
- 3 - Allow the burners to fire for approximately 3 minutes.
- 4 - Adjust the thermostat to deactivate the heating demand.
- 5 - Wait for the combustion air inducer to stop. Set the thermostat to initiate a heating demand and again allow the burners to fire for approximately 3 minutes.

- Adjust the thermostat to deactivate the heating demand and wait for the combustion air inducer to stop. At this point, the trap should be primed with sufficient water to ensure proper condensate drain operation.

**BEFORE LIGHTING** the unit, smell all around the furnace area for gas. Be sure to smell next to the floor because some gas is heavier than air and will settle on the floor.

The gas valve on the G43UF is equipped with a gas control switch (lever). Use only your hand to move switch. Never use tools. If the the switch will not move by hand, do not try to repair it. Force or attempted repair may result in a fire or explosion.

**Placing the furnace into operation:**

G43UF units are equipped with an automatic hot surface ignition system. Do not attempt to manually light burners on this furnace. Each time the thermostat calls for heat, the burners will automatically light. The ignitor does not get hot when there is no call for heat on these units.

**⚠ WARNING**

**If you do not follow these instructions exactly, a fire or explosion may result causing property damage, personal injury or death.**

**Gas Valve Operation (Figures 43 and 44)**

- STOP!** Read the safety information at the beginning of this section.
- Set the thermostat to the lowest setting.
- Turn off all electrical power to the unit.
- This furnace is equipped with an ignition device which automatically lights the burners. Do **not** try to light the burners by hand.
- Remove the upper access panel.
- White Rodgers 36G Gas Valve* - Move gas valve switch to **OFF**. See figure 43 for White Rodgers 36G valve.  
*Honeywell VR8205 Gas Valve* - Move gas valve switch to **OFF**. See figure 44 for Honeywell VR8205 valve.
- Wait five minutes to clear out any gas. If you then smell gas, **STOP!** Immediately call your gas supplier from a neighbor's phone. Follow the gas supplier's instructions. If you do not smell gas go to next step.

- White Rodgers 36G Gas Valve* - Move gas valve switch to **ON**. See figure 43 for White Rodgers 36G valve.  
*Honeywell VR8205 Gas Valve* - Move gas valve switch to **ON**. See figure 44 for Honeywell VR8205 valve.

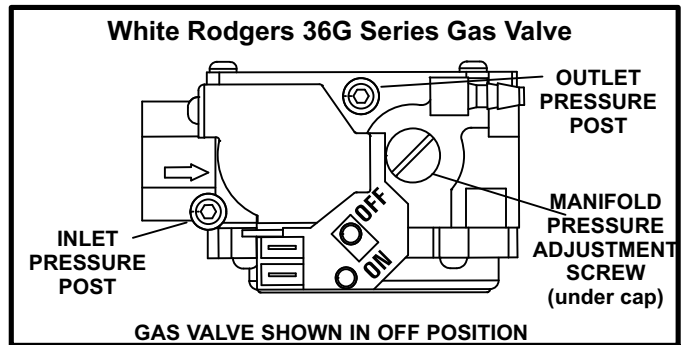

**FIGURE 43**

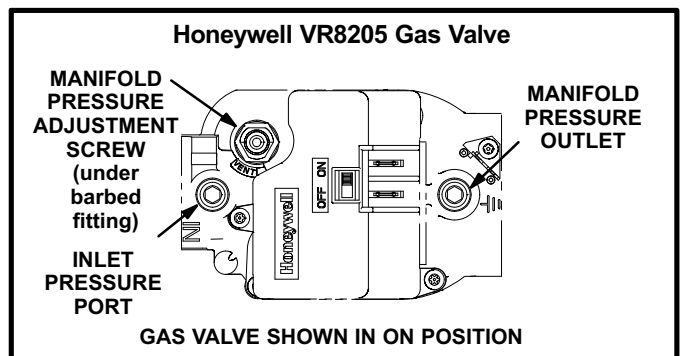

**FIGURE 44**

- Replace the upper access panel.
- Turn on all electrical power to the unit.
- Set the thermostat to desired setting.
- NOTE** - When unit is initially started, steps 1 through 11 may need to be repeated to purge air from gas line.
- If the appliance will not operate, follow the instructions "Turning Off Gas to Unit" and call your service technician or gas supplier.

**Turning Off Gas to Unit**

- Set the thermostat to the lowest setting.
- Turn off all electrical power to the unit if service is to be performed.
- Remove the upper access panel.
- White Rodgers 36G Gas Valve* - Move gas valve switch to **OFF**.  
*Honeywell VR8205 Gas Valve* - Move gas valve switch to **OFF**.
- Replace the upper access panel.



## Heating Sequence Of Operation

When thermostat calls for heat, combustion air inducer starts.

Combustion air pressure switch proves blower operation. Switch is factory set and requires no adjustment. After a 15-second prepurge, the hot surface ignitor energizes.

After a 20-second ignitor warm-up period, the gas valve solenoid opens.

Gas is ignited, flame sensor proves the flame, and the combustion process continues.

If flame is not detected after first ignition trial, the ignition control will repeat steps 3 and 4 four more times before locking out the gas valve ("WATCHGUARD" flame failure mode). The ignition control will then automatically repeat steps 1 through 6 after 60 minutes.

To interrupt the 60-minute "WATCHGUARD" period, move thermostat from "Heat" to "OFF" then back to "Heat". Heating sequence then restarts at step 1.

## Gas Pressure Adjustment

### Gas Flow (Approximate)

- Operate unit at least 15 minutes before checking gas flow. Determine the time in seconds for one revolutions of gas through the meter. A portable LP gas meter (17Y44) is available for LP applications.

TABLE 8

Gas Flow Rate (Ft. <sup>3</sup> /Hr.)		
Seconds for 1 Revolution	Gas Meter Size	
	1/2 cu ft Dial	1 cu ft Dial
10	180	360
12	150	300
14	129	257
16	113	225
18	100	200
20	90	180
22	82	164
24	75	150
26	69	138
28	64	129
30	60	120
32	56	113
34	53	106
36	50	100
38	47	95
40	45	90
42	43	86
44	41	82
46	39	78
48	38	75
50	36	72
52	35	69
54	33	67
56	32	64
58	31	62
60	30	60

- Compare the number of seconds and the gas meter size in table 8 to determine the gas flow rate. Multiply the gas flow rate by the heating value to determine the unit input rate. If manifold pressure is correct and the unit input rate is incorrect, check gas orifices for proper size and restriction.

- Remove temporary gas meter if installed.

**NOTE** - To obtain accurate reading, shut off all other gas appliances connected to meter.

### Gas Supply Pressure Measurement

A threaded plug on the inlet side of the gas valve provides access to the supply pressure tap. Remove the threaded plug, install a field-provided barbed fitting and connect a manometer to measure supply pressure. Replace the threaded plug after measurements have been taken.

### Manifold Pressure Measurement

To correctly measure manifold pressure, the differential pressure between the positive gas manifold and the negative burner box must be considered. Use pressure test adapter kit (available as Lennox part 10L34) to assist in measurement.

- Remove the threaded plug from the outlet side of the gas valve and install a field-provided barbed fitting. Connect test gauge "+" connection to barbed fitting to measure manifold pressure.
- Tee into the gas valve regulator vent hose and connect test gauge "-" connection.
- Start unit and allow 5 minutes for unit to reach steady state.
- While waiting for the unit to stabilize, notice the flame. Flame should be stable and should not lift from burner. Natural gas should burn blue.
- After allowing unit to stabilize for 5 minutes, record manifold pressure and compare to value given in table 9.

**NOTE** - Shut unit off and remove manometer as soon as an accurate reading has been obtained. Take care to remove barbed fitting and replace threaded plug.

**⚠ IMPORTANT**

The White Rodgers 36G gas valve (figure 43) is equipped with pressure posts for measuring supply and manifold pressures. The posts provide built-in hose connections and have an integral 3/32" Allen-head screw. Rotate the screw counterclockwise one full turn to permit pressure measurement. Reseat the screw (rotate one full turn clockwise) after measurements have been taken to prevent gas leakage.

## High Altitude Information

**NOTE** - In Canada, certification for installations at elevations over 4500 feet (1372 m) is the jurisdiction of local authorities.

The manifold pressure may require adjustment to ensure proper operation at higher altitudes. Refer to table 9 for proper manifold pressure settings at varying altitudes. Table 10 lists required pressure switch changes and conversion kits at varying altitudes.

The combustion air pressure switches are factory-set and require no adjustment.

**TABLE 9**  
**Manifold Pressure (Outlet) inches w.c.**

Fuel	Model Input Sizes	Altitude (feet)				
		0-4500	4501-5500	5501-6500	6501-7500	7501-10,000
Nat. Gas	All sizes	3.5	3.5	3.5	3.5	3.5*
L.P. Gas	All sizes	10.0**	10.0**	10.0**	10.0**	10.0**

\*Conversion kit required for applications at altitudes above 7501 ft. above sea level.

\*\*Conversion kit required for applications at all altitudes.

**NOTE** - A natural to L.P. propane gas changeover kit is necessary to convert this unit. Refer to the changeover kit installation instruction for the conversion procedure.

**TABLE 10**  
**Conversion Kit and Pressure Switch Requirements at Varying Altitudes**

Input	High Altitude Orifice Kit Natural Gas Only	High Altitude Pressure Switch Kit		LPG/Propane Kit	
	7501-10,000 ft.	4501-7500 ft.	7501-10,000 ft.	0-7500 ft.	7501-10,000 ft.
<b>-045</b>	<b>44W51</b>	- - -	<b>95M22</b>	<b>83M74</b>	<b>83M75</b>
<b>-070</b>	<b>44W51</b>	<b>56M05</b>	<b>56M06</b>	<b>83M74</b>	<b>83M75</b>
<b>-090</b>	<b>44W51</b>	<b>75M20</b>	<b>56M07</b>	<b>83M74</b>	<b>83M75</b>
<b>-110</b>	<b>44W51</b>	<b>75M20</b>	<b>56M07</b>	<b>83M74</b>	<b>83M75</b>
<b>-135</b>	<b>44W51</b>	<b>56M04</b>	<b>60M35</b>	<b>83M74</b>	<b>83M75</b>

Pressure switch is factory set. No adjustment necessary. All models use the factory installed pressure switch from 0-4500 feet (0-1370 m).

## Testing for Proper Venting and Sufficient Combustion Air for Non-Direct Vent Applications

### **WARNING**

#### **CARBON MONOXIDE POISONING HAZARD!**

**Failure to follow the steps outlined below for each appliance connected to the venting system being placed into operation could result in carbon monoxide poisoning or death.**

**The following steps shall be followed for each appliance connected to the venting system being placed into operation, while all other appliances connected to the venting system are not in operation.**

After the G43UF gas furnace has been started, the following test should be conducted to ensure proper venting and sufficient combustion air has been provided to the G43UF as well as to other gas-fired appliances which are separately vented.

If a G43UF furnace replaces a Category I furnace which was commonly vented with another gas appliance, the size of the existing vent pipe for that gas appliance must be checked. Without the heat of the original furnace flue products, the existing vent pipe is probably oversized for the single water heater or other appliance. The vent should be checked for proper draw with the remaining appliance.

The test should be conducted while all appliances (both in operation and those not in operation) are connected to the venting system being tested. If the venting system has been installed improperly, or if provisions have not been made for sufficient amounts of combustion air, corrections must be made as outlined in the previous section.

- 1 - Seal any unused openings in the venting system.
- 2 - Visually inspect the venting system for proper size and

horizontal pitch. Determine there is no blockage or restriction, leakage, corrosion, or other deficiencies which could cause an unsafe condition.

- 3 - To the extent that it is practical, close all building doors and windows and all doors between the space in which the appliances connected to the venting system are located and other spaces of the building.
- 4 - Close fireplace dampers.
- 5 - Turn on clothes dryers and any appliances not connected to the venting system. Turn on any exhaust fans, such as range hoods and bathroom exhausts, so they will operate at maximum speed. Do not operate a summer exhaust fan.
- 6 - Follow the lighting instruction to place the appliance being inspected into operation. Adjust thermostat so appliance will operate continuously.
- 7 - Use the flame of match or candle to test for spillage of flue gases at the draft hood relief opening after 5 minutes of main burner operation.
- 8 - If improper venting is observed during any of the above tests, the venting system must be corrected or sufficient combustion/make-up air must be provided. The venting system should be re-sized to approach the minimum size as determined by using the appropriate tables in appendix G in the current standards of the National Fuel Gas Code ANSI-Z223.1/NPFA 54 in the U.S.A., and the appropriate Natural Gas and Propane appliances venting sizing tables in the current standard of the CSA-B149 Natural Gas and Propane Installation Codes in Canada.
- 9 - After determining that each appliance remaining connected to the common venting system properly vents when tested as indicated in step 3, return doors, windows, exhaust fans, fireplace dampers and any other gas-burning appliance to their previous condition of use.

## Other Unit Adjustments

### Primary Limit

The primary limit is located on the heating compartment vestibule panel. This limit is factory set and requires no adjustment.

### Flame Rollout Switches (Two)

These manually reset switches are located on the burner box. If tripped, check for adequate combustion air before resetting.

### Pressure Switch

The pressure switch is located in the heating compartment on the combustion air inducer. This switch checks for proper combustion air inducer operation before allowing ignition trial. The switch is factory-set and requires no adjustment.

### Temperature Rise

After the furnace has been started and supply and return air temperatures have been allowed to stabilize, check the temperature rise. If necessary, adjust the blower speed to maintain the temperature rise within the range shown on the unit nameplate. Increase the blower speed to decrease the temperature. Decrease the blower speed to increase the temperature rise. Failure to adjust the temperature rise may cause erratic limit operation.

### Fan Control

The fan on time of 45 seconds is not adjustable. The fan off delay (amount of time that the blower operates after the heat demand has been satisfied) may be adjusted by changing the jumper position across the five pins on the integrated control. The unit is shipped with a factory fan off setting of 90 seconds. The fan off delay affects comfort and is adjustable to satisfy individual applications. Adjust the fan off delay to achieve a supply air temperature between 90° and 110°F at the exact moment that the blower is de-energized. Longer off delay settings provide lower return air temperatures; shorter settings provide higher return air temperatures. See figure 45.

#### FAN-OFF TIME ADJUSTMENT

JUMPER POSITION		HEAT OFF DELAY
OFF	OFF	180
PIN1	PIN2	60
PIN2	PIN3	90
PIN3	PIN4	120
PIN4	PIN5	180

To adjust fan-off timing, reposition jumper across pins to achieve desired setting.

FIGURE 45

### Thermostat Heat Anticipation

Set the heat anticipator setting (if adjustable) according to the amp draw listed on the wiring diagram that is attached to the unit.

### Electrical

- 1 - Check all wiring for loose connections.
- 2 - Check for the correct voltage at the furnace (furnace operating).
- 3 - Check amp-draw on the blower motor.  
Motor Nameplate \_\_\_\_\_ Actual \_\_\_\_\_

**NOTE** - Do not secure the electrical conduit directly to the air ducts or structure.

### Blower Speeds

**NOTE** - CFM readings are taken external to unit with a dry evaporator coil and without accessories.

Turn off electrical power to furnace.

Remove blower access panel.

Disconnect existing speed tap at control board speed terminal.

**NOTE** - Termination of any unused motor leads must be insulated.

Refer to blower speed selection chart on unit wiring diagram for desired heating or cooling speed. See Blower performance data beginning on Page 37.

Connect selected speed tap at control board speed terminal.

Resecure blower access panel.

Turn on electrical power to furnace.

### Electronic Ignition

The integrated control has an added feature of an internal Watchguard control. The feature serves as an automatic reset device for ignition control lockout caused by ignition failure. This type of lockout is usually due to low gas line pressure. After one hour of continuous thermostat demand for heat, the Watchguard will break and remake thermostat demand to the furnace and automatically reset the control to begin the ignition sequence.

### Exhaust and Air Intake Pipe

- 1 - Check exhaust and air intake connections for tightness and to make sure there is no blockage.
- 2 - Is pressure switch closed? Obstructed exhaust pipe will cause unit to shut off at pressure switch. Check termination for blockages.
- 3 - Reset manual flame rollout switches on burner box cover.

### Failure To Operate

If the unit fails to operate, check the following:

- 1 - Is the thermostat calling for heat?
- 2 - Are access panels securely in place?
- 3 - Is the main disconnect switch closed?
- 4 - Is there a blown fuse?
- 5 - Is the filter dirty or plugged? Dirty or plugged filters will cause the limit control to shut the unit off.
- 6 - Is gas turned on at the meter?
- 7 - Is the manual main shut-off valve open?
- 8 - Is the internal manual shut-off valve open?
- 9 - Is the unit ignition system in lock out? If the unit locks out again, inspect the unit for blockages.

## Blower Motor Performance

### G43UF-24B-045 PERFORMANCE (Less Filter)

External Static Pressure in. w.g.	Air Volume / Watts at Different Blower Speeds							
	High		Medium-High		Medium-Low		Low	
	cfm	Watts	cfm	Watts	cfm	Watts	cfm	Watts
0.00	1125	425	900	360	745	295	690	265
0.10	1115	410	905	350	760	285	695	260
0.20	1090	395	895	335	755	280	685	255
0.30	1060	380	880	325	740	270	675	250
0.40	1020	365	860	315	720	260	665	240
0.50	970	345	835	300	700	255	640	230
0.60	920	335	795	290	665	240	600	220
0.70	860	315	730	270	620	230	565	215
0.80	760	295	665	250	560	215	510	200
0.90	675	275	585	230	495	200	465	175

### G43UF-24B-070 PERFORMANCE (Less Filter)

External Static Pressure in. w.g.	Air Volume / Watts at Different Blower Speeds							
	High		Medium-High		Medium-Low		Low	
	cfm	Watts	cfm	Watts	cfm	Watts	cfm	Watts
0.00	1115	435	875	360	720	290	665	255
0.10	1115	425	865	350	725	285	670	255
0.20	1100	415	870	335	730	280	665	250
0.30	1080	400	870	330	725	270	655	240
0.40	1050	385	855	320	715	265	645	240
0.50	1010	365	835	310	695	255	625	230
0.60	980	355	810	295	675	250	600	225
0.70	930	340	770	285	640	235	565	215
0.80	855	320	720	270	585	220	520	200
0.90	770	295	650	250	525	205	465	190

NOTES - All air data is measured external to unit without filter (not furnished - field provided).

### G43UF-36B-070 PERFORMANCE (Less Filter)

External Static Pressure in. w.g.	Air Volume / Watts at Different Blower Speeds							
	High		Medium-High		Medium-Low		Low	
	cfm	Watts	cfm	Watts	cfm	Watts	cfm	Watts
0.00	1640	660	1415	575	1160	485	1005	410
0.10	1600	635	1395	550	1160	460	1000	385
0.20	1540	605	1370	525	1160	445	995	375
0.30	1495	580	1345	505	1145	425	990	365
0.40	1420	545	1275	480	1125	395	965	345
0.50	1360	525	1245	450	1080	375	945	325
0.60	1275	490	1165	410	1025	350	900	305
0.70	1170	465	1085	385	965	335	860	295
0.80	1080	440	1010	360	865	310	775	270
0.90	945	400	840	320	765	275	710	245

### G43UF-36C-090(H) PERFORMANCE (Less Filter)

External Static Pressure in. w.g.	Air Volume / Watts at Different Blower Speeds							
	High		Medium-High		Medium-Low		Low	
	cfm	Watts	cfm	Watts	cfm	Watts	cfm	Watts
0.00	1630	745	1360	635	1125	540	975	440
0.10	1620	715	1365	610	1160	515	1000	430
0.20	1590	680	1365	580	1160	495	990	405
0.30	1550	655	1355	565	1170	475	985	395
0.40	1520	630	1330	545	1160	460	980	380
0.50	1465	605	1300	515	1140	440	960	360
0.60	1415	570	1250	490	1095	420	940	350
0.70	1350	545	1215	470	1065	400	905	335
0.80	1260	510	1140	440	1005	375	850	310
0.90	1165	475	1035	395	900	335	730	285

NOTES - All air data is measured external to unit without filter (not furnished - field provided).

Air volume based on bottom air return air. Actual air volume may vary on side return air applications.

### G43UF-48C-090 PERFORMANCE (Less Filter)

External Static Pressure in. w.g.	Air Volume / Watts at Different Blower Speeds							
	High		Medium-High		Medium-Low		Low	
	cfm	Watts	cfm	Watts	cfm	Watts	cfm	Watts
0.00	2180	930	1835	790	1520	630	1280	510
0.10	2135	885	1825	750	1510	610	1275	495
0.20	2085	840	1810	720	1505	580	1270	475
0.30	2030	800	1775	685	1500	565	1265	460
0.40	1940	760	1735	650	1480	535	1250	440
0.50	1865	725	1660	600	1430	505	1215	425
0.60	1740	670	1590	575	1380	475	1175	410
0.70	1645	640	1475	520	1290	450	1105	375
0.80	1540	600	1340	465	1175	405	1020	355
0.90	1335	540	1170	440	1070	375	950	330

### G43UF-48C-110(H) PERFORMANCE (Less Filter)

External Static Pressure in. w.g.	Air Volume / Watts at Different Blower Speeds							
	High		Medium-High		Medium-Low		Low	
	cfm	Watts	cfm	Watts	cfm	Watts	cfm	Watts
0.00	2160	880	1880	755	1490	602	1235	485
0.10	2100	850	1855	730	1480	585	1230	475
0.20	2035	805	1815	690	1475	560	1225	460
0.30	1965	750	1755	650	1475	545	1220	445
0.40	1885	725	1715	625	1465	510	1215	430
0.50	1780	680	1630	580	1420	490	1150	400
0.60	1690	660	1550	550	1360	460	1110	380
0.70	1575	620	1410	505	1210	405	1035	350
0.80	1375	550	1230	450	1125	380	970	325
0.90	1225	520	1120	415	1050	365	885	310

NOTES - All air data is measured external to unit without filter (not furnished - field provided).

Air volume based on bottom air return air. Actual air volume may vary on side return air applications.

**G43UF-60C-110 PERFORMANCE (Less Filter)**

External Static Pressure in. w.g.	Bottom Return Air, Side Return Air with Optional RAB Return Air Base, Return Air from Both Sides or Return Air from Bottom and One Side.								Single Side Return Air - Air volumes in bold require field fabricated transition to accommodate 20 x 25 x 1 in. air filter in order to maintain proper air velocity.							
	Air Volume / Watts at Different Blower Speeds								Air Volume / Watts at Different Blower Speeds							
	High		Medium-High		Medium-Low		Low		High		Medium-High		Medium-Low		Low	
	cfm	Watts	cfm	Watts	cfm	Watts	cfm	Watts	cfm	Watts	cfm	Watts	cfm	Watts	cfm	Watts
0.00	2720	1385	2410	1090	2055	935	1620	710	<b>2625</b>	<b>1350</b>	<b>2310</b>	<b>1080</b>	<b>1885</b>	<b>885</b>	1515	700
0.10	2665	1355	2385	1075	2025	885	1730	735	<b>2570</b>	<b>1330</b>	<b>2325</b>	<b>1060</b>	<b>1910</b>	<b>865</b>	1575	700
0.20	2585	1315	2350	1015	2030	865	1680	690	<b>2410</b>	<b>1305</b>	<b>2285</b>	<b>1035</b>	<b>1930</b>	<b>845</b>	1620	690
0.30	2505	1275	2290	990	2025	840	1695	675	<b>2425</b>	<b>1265</b>	<b>2230</b>	<b>990</b>	<b>1925</b>	<b>825</b>	1635	675
0.40	2435	1250	2235	940	2030	830	1695	660	<b>2335</b>	<b>1220</b>	<b>2175</b>	<b>950</b>	<b>1910</b>	<b>810</b>	1640	660
0.50	2350	1205	2170	930	1975	790	1735	665	<b>2270</b>	<b>1195</b>	<b>2120</b>	<b>935</b>	<b>1895</b>	<b>785</b>	1640	640
0.60	2255	1185	2100	895	1915	765	1720	650	<b>2170</b>	<b>1155</b>	<b>2045</b>	<b>885</b>	<b>1860</b>	<b>765</b>	1630	630
0.70	2160	1150	2005	840	1865	730	1680	635	<b>2110</b>	<b>1130</b>	<b>1950</b>	<b>855</b>	1795	730	1590	610
0.80	2020	1090	1905	825	1810	710	1625	610	<b>2035</b>	<b>1090</b>	<b>1885</b>	<b>820</b>	1745	705	1540	580
0.90	1910	1050	1820	795	1705	675	1540	590	<b>1900</b>	<b>1055</b>	1760	780	1665	680	1470	565

**G43UF-60D-135 PERFORMANCE (Less Filter)**

External Static Pressure in. w.g.	Bottom Return Air, Side Return Air with Optional RAB Return Air Base, Return Air from Both Sides or Return Air from Bottom and One Side.								Single Side Return Air - Air volumes in bold require field fabricated transition to accommodate 20 x 25 x 1 in. air filter in order to maintain proper air velocity.							
	Air Volume / Watts at Different Blower Speeds								Air Volume / Watts at Different Blower Speeds							
	High		Medium-High		Medium-Low		Low		High		Medium-High		Medium-Low		Low	
	cfm	Watts	cfm	Watts	cfm	Watts	cfm	Watts	cfm	Watts	cfm	Watts	cfm	Watts	cfm	Watts
0.00	2730	1465	2425	1125	2055	915	1560	680	<b>2665</b>	<b>1440</b>	<b>2325</b>	<b>1100</b>	<b>1865</b>	<b>890</b>	1410	690
0.10	2670	1440	2400	1100	2065	890	1590	675	<b>2615</b>	<b>1405</b>	<b>2310</b>	<b>1065</b>	<b>1915</b>	<b>865</b>	1465	685
0.20	2600	1400	2365	1070	2045	865	1620	665	<b>2530</b>	<b>1370</b>	<b>2280</b>	<b>1055</b>	<b>1925</b>	<b>850</b>	1570	675
0.30	2525	1360	2315	1045	2035	845	1615	655	<b>2470</b>	<b>1330</b>	<b>2235</b>	<b>1015</b>	<b>1920</b>	<b>825</b>	1590	670
0.40	2445	1325	2260	1015	2020	820	1615	645	<b>2380</b>	<b>1290</b>	<b>2175</b>	<b>985</b>	<b>1910</b>	<b>805</b>	1590	655
0.50	2360	1280	2195	985	1960	790	1610	635	<b>2310</b>	<b>1265</b>	<b>2120</b>	<b>965</b>	<b>1890</b>	<b>790</b>	1595	645
0.60	2290	1255	2130	965	1900	755	1600	615	<b>2200</b>	<b>1230</b>	<b>2055</b>	<b>935</b>	<b>1835</b>	<b>765</b>	1580	630
0.70	2205	1220	2035	910	1825	730	1570	600	<b>2120</b>	<b>1190</b>	<b>1970</b>	<b>900</b>	1790	740	1545	605
0.80	2110	1195	1945	880	1765	710	1540	580	<b>2025</b>	<b>1160</b>	<b>1890</b>	<b>875</b>	1720	710	1515	590
0.90	1970	1120	1835	830	1680	690	1540	545	<b>1930</b>	<b>1110</b>	<b>1800</b>	<b>835</b>	1655	685	1440	570

## Service

### **⚠ WARNING**

#### **ELECTRICAL SHOCK, FIRE, OR EXPLOSION HAZARD.**

**Failure to follow safety warnings exactly could result in dangerous operation, serious injury, death or property damage.**

**Improper servicing could result in dangerous operation, serious injury, death, or property damage.**

**Before servicing, disconnect all electrical power to furnace.**

**When servicing controls, label all wires prior to disconnecting. Take care to reconnect wires correctly. Verify proper operation after servicing.**

At the beginning of each heating season, system should be checked as follows by a qualified service technician:

#### **Blower**

Check the blower wheel for debris and clean if necessary. The blower motors are prelubricated for extended bearing life. No further lubrication is needed.

### **⚠ WARNING**

**The blower access panel must be securely in place when the blower and burners are operating. Gas fumes, which could contain carbon monoxide, can be drawn into living space resulting in personal injury or death.**

#### **Filters**

All G43UF filters are installed external to the unit. Filters should be inspected monthly. Clean or replace the filters when necessary to ensure proper furnace operation. Table 1 lists recommended filter sizes.

#### **Exhaust and air intake pipes**

Check the exhaust and air intake pipes and all connections for tightness and to make sure there is no blockage.

**NOTE** - After any heavy snow, ice or frozen fog event the furnace vent pipes may become restricted. Always check the vent system and remove any snow or ice that may be obstructing the plastic intake or exhaust pipes.

#### **Electrical**

- 1 - Check all wiring for loose connections.
- 2 - Check for the correct voltage at the furnace (furnace operating).
- 3 - Check amp-draw on the blower motor.  
Motor Nameplate \_\_\_\_\_ Actual \_\_\_\_\_

#### **Winterizing and Condensate Trap Care**

- 1 - Turn off power to the unit.
- 2 - Have a shallow pan ready to empty condensate water.

- 3 - Remove the drain plug from the condensate trap and empty water. Inspect the trap then reinstall the drain plug.

#### **Cleaning Heat Exchanger**

If cleaning the heat exchanger becomes necessary, follow the below procedures and refer to figure 1 when disassembling unit. Use papers or protective covering in front of furnace while removing heat exchanger assembly.

- 1 - Turn off electrical and gas supplies to the furnace.
- 2 - Remove the upper and lower furnace access panels.
- 3 - Mark all gas valve wires and disconnect them from valve.
- 4 - Remove gas supply line connected to gas valve. Remove gas valve/manifold assembly.
- 5 - Remove sensor wire from sensor. Disconnect 2-pin plug from the ignitor.
- 6 - Disconnect wires from flame roll-out switches.
- 7 - Remove burner box cover and remove four burner box screws at the vestibule panel and remove burner box. Set burner box assembly aside.  
**NOTE** - If necessary, clean burners at this time. Follow procedures outlined in Burner Cleaning section.
- 8 - Loosen three clamps and remove flexible exhaust tee.
- 9 - Remove 3/8 inch rubber cap from condensate drain trap and drain. Replace cap after draining.
- 10 - Disconnect condensate drain line from the condensate trap. Remove condensate trap (it may be necessary to cut drain pipe). Remove screws that secure condensate collars to either side of the furnace and remove collars. Remove drain tubes from cold end header collector box.
- 11 - Disconnect condensate drain tubing from flue collar. Remove screws that secure both flue collars into place. Remove flue collars. It may be necessary to cut the exiting exhaust pipe for removal of the fittings.
- 12 - Disconnect the 2-pin plug from the combustion air inducer. Remove four screws which secure combustion air inducer to collector box. Remove combustion air inducer assembly. Remove ground wire.
- 13 - Mark and disconnect all combustion air pressure tubing from cold end header collector box.
- 14 - Mark and remove wires from pressure switch. Remove pressure switch. Keep tubing attached to pressure switch.
- 15 - Remove electrical junction box from the side of the furnace.
- 16 - Mark and disconnect any remaining wiring to heating compartment components. Disengage strain relief bushing and pull wiring and bushing through the hole in the blower deck.
- 17 - Remove the primary limit from the vestibule panel.
- 18 - Remove two screws from the front cabinet flange at the blower deck. Spread cabinet sides slightly to allow clearance for removal of heat exchanger.

- 19 - Remove screws along vestibule sides and bottom which secure vestibule panel and heat exchanger assembly to cabinet. Remove two screws from blower rail which secure bottom heat exchanger flange. Remove heat exchanger from furnace cabinet.
  - 20 - Back wash heat exchanger with soapy water solution or steam. **If steam is used it must be below 275°F (135°C) .**
  - 21 - Thoroughly rinse and drain the heat exchanger. Soap solutions can be corrosive. Take care to rinse entire assembly.
  - 22 - Reinstall heat exchanger into cabinet making sure that the clamshells of the heat exchanger assembly are resting on the support located at the rear of the cabinet. Remove the indoor blower to view this area through the blower opening.
  - 23 - Re-secure the supporting screws along the vestibule sides and bottom to the cabinet.
  - 24 - Reinstall cabinet screws on front flange at blower deck.
  - 25 - Reinstall the primary limit on the vestibule panel.
  - 26 - Route heating component wiring through hole in blower deck and reinsert strain relief bushing.
  - 27 - Reinstall pressure switch and reconnect pressure switch wiring.
  - 28 - Carefully connect combustion air pressure switch hosing from pressure switch to proper stubs on cold end header collector box.
  - 29 - Reinstall condensate collars on each side of the furnace. Reconnect drain tubing to collector box.
  - 30 - Reinstall condensate trap on same side as exhaust pipe. Reconnect condensate drain line to the condensate trap.
  - 31 - Reinstall electrical junction box.
  - 32 - Reinstall the combustion air inducer. Reconnect the 2-pin plug to the wire harness.
  - 33 - Use securing screws to reinstall flue collars to either side of the furnace. Reconnect exhaust piping and exhaust drain tubing.
  - 34 - Replace flexible exhaust tee on combustion air inducer and flue collars. Secure using three existing hose clamps.
  - 35 - Reinstall burner box assembly in vestibule area.
  - 36 - Reconnect flame roll-out switch wires.
  - 37 - Reconnect sensor wire and reconnect 2-pin plug from ignitor.
  - 38 - Secure burner box assembly to vestibule panel using four existing screws. **Make sure burners line up in center of burner ports.**
  - 39 - Reinstall gas valve manifold assembly. Reconnect gas supply line to gas valve.
  - 40 - Reinstall burner box cover.
  - 41 - Reconnect wires to gas valve.
  - 42 - Replace the blower compartment access panel.
  - 43 - Refer to instruction on verifying gas and electrical connections when re-establishing supplies.
  - 44 - Follow lighting instructions to light and operate furnace for 5 minutes to ensure that heat exchanger is clean and dry and that furnace is operating properly.
  - 45 - Replace heating compartment access panel.
- Cleaning the Burner Assembly**
- 1 - Turn off electrical and gas power supplies to furnace. Remove upper and lower furnace access panels.
  - 2 - Mark all gas valve wires and disconnect them from the valve.
  - 3 - Disconnect the gas supply line from the gas valve. Remove gas valve/manifold assembly.
  - 4 - Mark and disconnect sensor wire from the sensor. Disconnect 2-pin plug from the ignitor at the burner box.
  - 5 - Remove burner box cover and remove four screws which secure burner box assembly to vest panel. Remove burner box from the unit.
  - 6 - Use the soft brush attachment on a vacuum cleaner to gently clean the face of the burners. Visually inspect the inside of the burners and crossovers for any blockage caused by foreign matter. Remove any blockage.
  - 7 - Reconnect the sensor wire and reconnect the 2-pin plug to the ignitor wiring harness.
  - 8 - Reinstall the burner box assembly using the existing four screws. Make sure that the burners line up in the center of the burner ports.
  - 9 - Reinstall the gas valve manifold assembly. Reconnect the gas supply line to the gas valve. Reinstall the burner box cover.
  - 10 - Reconnect the gas valve wires to the gas valve.
  - 11 - Replace the blower compartment access panel.
  - 12 - Refer to instruction on verifying gas and electrical connections when re-establishing supplies.
  - 13 - Follow lighting instructions to light and operate furnace for 5 minutes to ensure that heat exchanger is clean and dry and that furnace is operating properly.
  - 14 - Replace heating compartment access panel.



## Planned Service

A service technician should check the following items during an annual inspection. Power to the unit must be shut off for safety.

**Fresh air grilles and louvers** (on the unit and in the room where the furnace is installed) - Must be open and unobstructed to provide combustion air.

**Burners** - Must be inspected for rust, dirt, or signs of water.

**Vent pipe** - Must be inspected for signs of water, cracked, damaged or sagging pipe, or disconnected joints.

**Unit appearance** - Must be inspected for rust, dirt, signs of water, burnt or damaged wires, or components.

**Blower access door** - Must be properly in place and provide a seal between the return air and the room where the furnace is installed.

**Return air duct** - Must be properly attached and provide an air seal to the unit.

**Operating performance** - Unit must be observed during operation to monitor proper performance of the unit and the vent system.

**Combustion gases** - Flue products must be analyzed and compared to the unit specifications.

Problems detected during the inspection may make it necessary to temporarily shut down the furnace until the items can be repaired or replaced.

**Instruct the homeowners to pay attention to their furnace.** Situations can arise between annual furnace inspections that may result in unsafe operation. For instance, items innocently stored next to the furnace may obstruct the combustion air supply. This could cause incomplete combustion and the production of carbon monoxide gas.

## Ignition Control Board Diagnostic Codes

DIAGNOSTIC CODES		
Make sure to Identify LED'S Correctly.		
LED #1 (Red)	LED #2 (Green)	DESCRIPTION
SIMULTANEOUS SLOW FLASH	SIMULTANEOUS SLOW FLASH	Power on - Normal operation. Also signaled during cooling and continuous fan.
SIMULTANEOUS FAST FLASH	SIMULTANEOUS FAST FLASH	Normal operation - signaled when heating demand initiated at thermostat.
SLOW FLASH	ON	Primary or secondary limit switch open. Limit must close within 3 minutes or unit goes into 1 hour Watchguard.
OFF	SLOW FLASH	Pressure prove switch open. OR: Blocked inlet/exhaust vent; OR: Pressure switch closed prior to activation of combustion air inducer.
ALTERNATING SLOW FLASH	ALTERNATING SLOW FLASH	Watchguard -- burners failed to ignite or lost flame 5 times during single heating demand.
SLOW FLASH	OFF	Flame sensed without gas valve energized.
ON	SLOW FLASH	Rollout switch open. OR: 12-pin connector improperly attached.
ON	ON	Circuit board failure or control wired incorrectly.
ON	OFF	
OFF	ON	
FAST FLASH	SLOW FLASH	Main power polarity reversed. Switch line and neutral.
SLOW FLASH	FAST FLASH	Low flame signal. Measures below 1.5 microamps. Replace flame sense rod.
ALTERNATING FAST FLASH	ALTERNATING FAST FLASH	Improper main ground. OR: Line voltage below 90 volts.

**NOTE** - Slow flash rate equals 1 Hz (one flash per second). Fast flash rate equals 3 Hz (three flashes per second). Minimum flame sense current = 0.5 microAmps.

# Troubleshooting: Heating Sequence of Operation

## HEATING SEQUENCE OF OPERATION

### NORMAL HEATING MODE

### ABNORMAL HEATING MODE

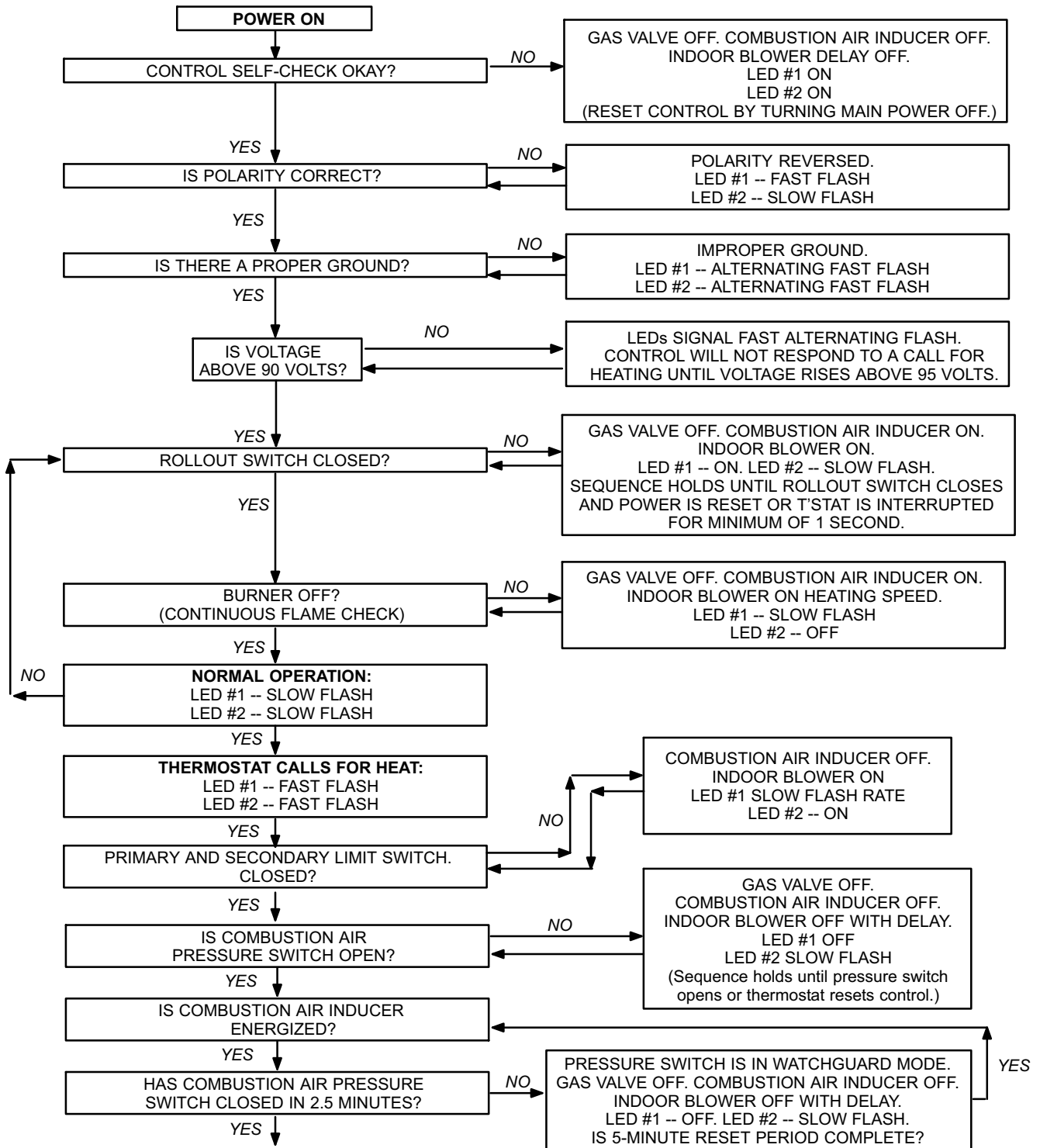

CONTINUED NEXT PAGE

**Troubleshooting: Heating Sequence of Operation (Continued)**

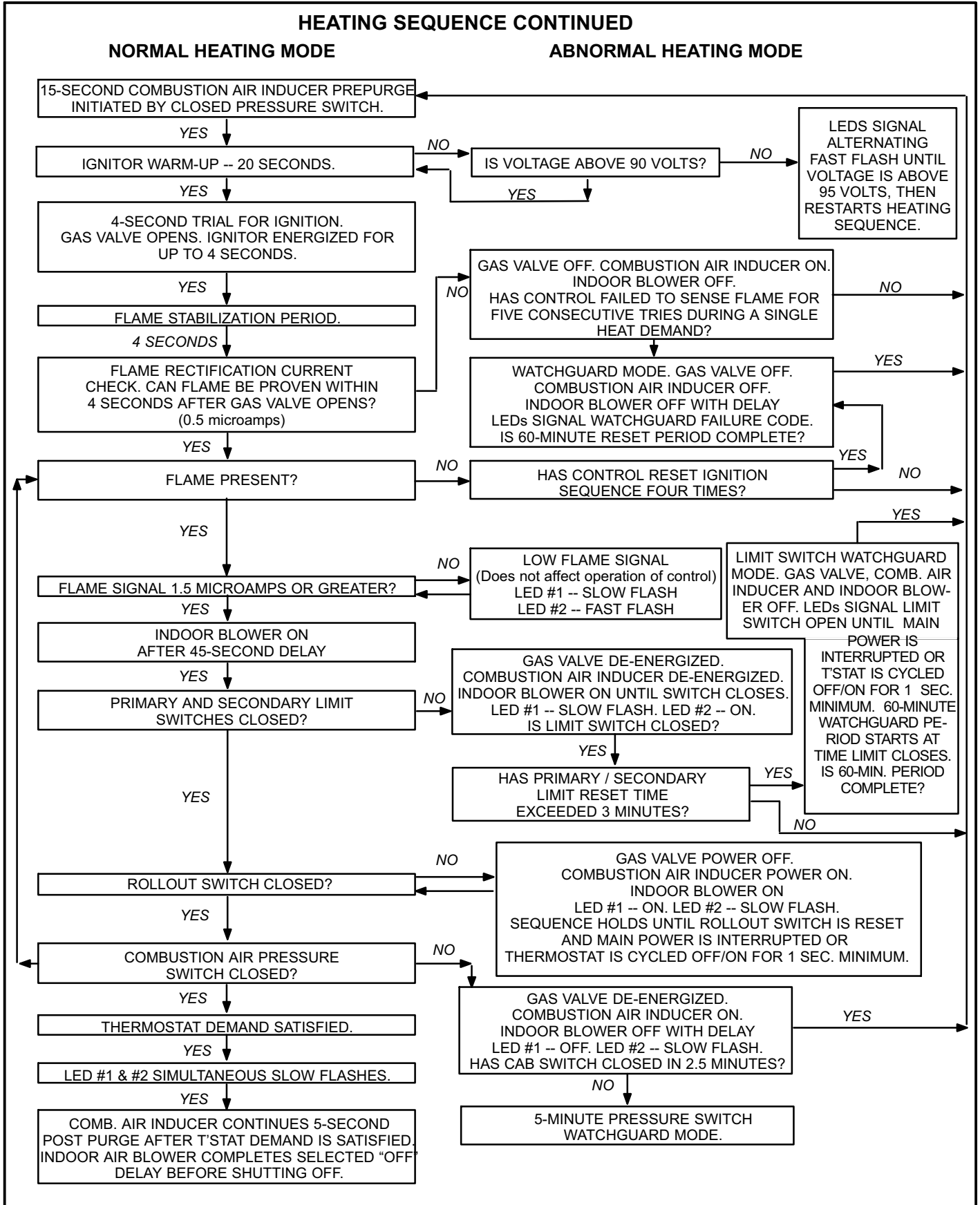

# Troubleshooting: Cooling Sequence of Operation

## COOLING SEQUENCE OF OPERATION

### NORMAL COOLING MODE

### ABNORMAL COOLING MODE

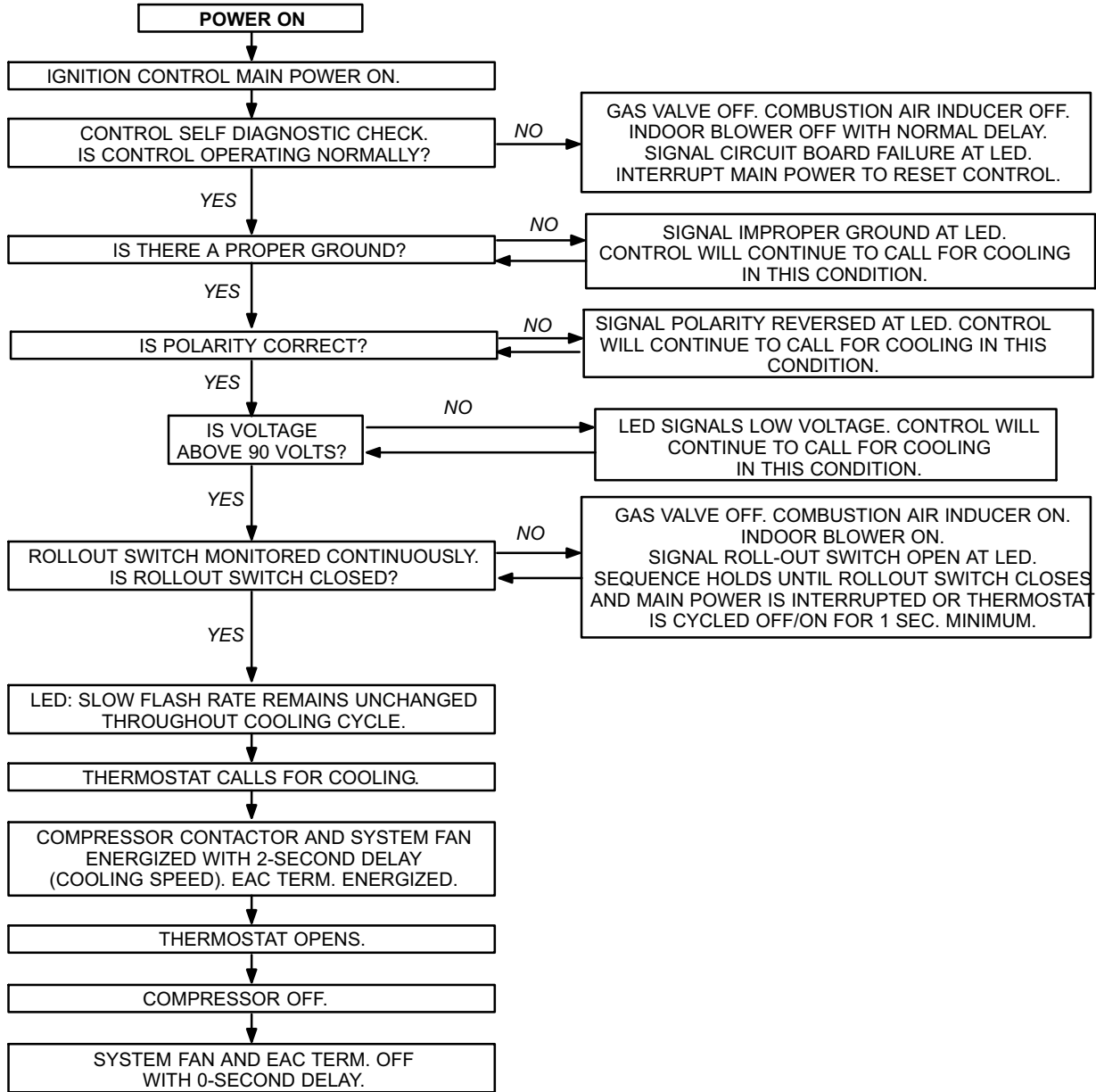

## Troubleshooting: Continuous Fan Sequence of Operation

### CONTINUOUS HEAT SPEED FAN SEQUENCE OF OPERATION

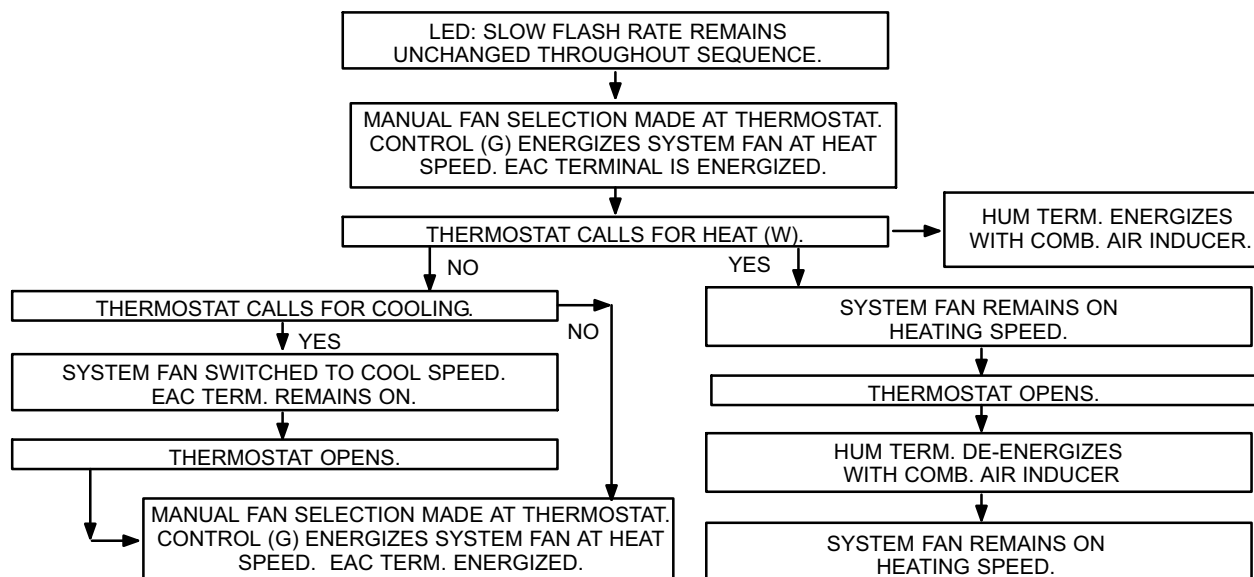

## Repair Parts List

The following repair parts are available through Lennox dealers. When ordering parts, include the complete furnace model number listed on the CSA nameplate -- Example: G43UF-24B-045-3. **All service must be performed by a licensed professional installer (or equivalent), service agency, or gas supplier.**

### Cabinet Parts

- Upper access panel
- Blower access panel
- Top Cap

### Control Panel Parts

- Transformer
- Integrated control board
- Door interlock switch

### Blower Parts

- Blower wheel
- Motor
- Motor mounting frame
- Motor capacitor
- Blower housing cutoff plate

### Heating Parts

- Flame Sensor
- Heat exchanger assembly
- Gas manifold
- Combustion air inducer
- Gas valve
- Main burner cluster
- Main burner orifices
- Pressure switch
- Ignitor
- Primary limit control
- Flame rollout switches
- Combustion air inducer auxiliary limit

## Vent Pipe Sizing Worksheet

<b>Step 1</b>	Proposed vent pipe size : _____	<b>Equivalent Feet</b>
<b>Step 2</b>	Termination kit catalog number : _____ Vent pipe equivalency value from table 3 : _____	
<b>Step 3</b>	Total number of 90° elbows required (indoors and outdoors) _____ X 5 = _____ equivalent feet of pipe	
<b>Step 4</b>	Total number of 45° elbows required (indoors and outdoors) _____ X 2.5 = _____ equivalent feet of pipe	
<b>Step 5</b>	Linear feet of straight pipe required : _____	
<b>Step 6</b>	Add equivalent feet of vent pipe listed in steps 2 through 5.	<b>TOTAL</b>

If the total is equal to, or less than, the allowable maximum given in table 5, the proposed pipe size is acceptable. If the total exceeds the maximum allowed vent pipe length, repeat the process above using the next larger diameter pipe until an acceptable total is achieved.

**NOTE** - In Direct Vent systems, total the equivalent length of either the exhaust OR intake piping run, depending upon which will be LONGER. Intake and exhaust pipe diameter must be the same size and must be terminated in the same pressure zone. Intake and exhaust pipe should be roughly the same length.

## G43UF Start-Up & Performance Check List

Job Name \_\_\_\_\_ Job No. \_\_\_\_\_ Date \_\_\_\_\_  
 Job Location \_\_\_\_\_ City \_\_\_\_\_ State \_\_\_\_\_  
 Installer \_\_\_\_\_ City \_\_\_\_\_ State \_\_\_\_\_  
 Unit Model No. \_\_\_\_\_ Technician \_\_\_\_\_  
 Serial No. \_\_\_\_\_

**Heating Section**

Electrical Connections Tight?   
 Supply Voltage \_\_\_\_\_ Blower Motor H.P. \_\_\_\_\_  
 Blower Motor Amps  Gas Piping Connections Tight & Leak-Tested?   
 Fuel Type: Natural Gas?  LP/Propane Gas?   
 Furnace Btu Input \_\_\_\_\_  
 Line Pressure \_\_\_\_\_  
 Regulator Pressure \_\_\_\_\_ w.c. - Nat.: \_\_\_\_\_ w.c. - LP/Propane  
 Flue Connections Tight?  Proper Draft?   
 Condensate Connections Tight?   
 Combustion Gas Tested?  CO<sub>2</sub>  CO  
 Fan Control Setting (45 Seconds Fixed On) \_\_\_\_\_  
 Fan Control Off Setting \_\_\_\_\_ Temperature Rise \_\_\_\_\_  
 Filter Clean & Secure?  Vent Clear?

**Thermostat**

Calibrated?  Heat Anticipator Properly Set?  Level?

## Requirements for Commonwealth of Massachusetts

### Modifications to NFPA-54, Chapter 10

#### Revise NFPA-54 section 10.8.3 to add the following requirements:

For all side wall, horizontally vented, gas-fueled equipment installed in every dwelling, building or structure used in whole or in part for residential purposes, including those owned or operated by the Commonwealth and where the side wall exhaust vent termination is less than seven (7) feet above the finished grade in the area of the venting, including but not limited to decks and porches, the following requirements shall be satisfied:

- 1 - **INSTALLATION OF CARBON MONOXIDE DETECTORS.** At the time of installation of the side wall, horizontally vented, gas-fueled equipment, the installing plumber or gasfitter shall observe that a hard-wired carbon monoxide detector with an alarm and battery backup is installed on the floor level where the gas equipment is to be installed. In addition, the installing plumber or gasfitter shall observe that a battery-operated or hard-wired carbon monoxide detector with an alarm is installed on each additional level of the dwelling, building or structure served by the side wall, horizontally vented, gas-fueled equipment. It shall be the responsibility of the property owner to secure the services of qualified licensed professionals for the installation of hard-wired carbon monoxide detectors.
  - a - In the event that the side wall, horizontally vented, gas-fueled equipment is installed in a crawl space or an attic, the hard-wired carbon monoxide detector with alarm and battery back-up may be installed on the next adjacent floor level.
  - b - In the event that the requirements of this subdivision cannot be met at the time of completion of installation, the owner shall have a period of thirty (30) days to comply with the above requirements; provided, however, that during said thirty (30) day period, a battery-operated carbon monoxide detector with an alarm shall be installed.
- 2 - **APPROVED CARBON MONOXIDE DETECTORS.** Each carbon monoxide detector as required in accordance with the above provisions shall comply with NFPA 720 and be ANSI/UL 2034 listed and IAS certified.
- 3 - **SIGNAGE.** A metal or plastic identification plate shall be permanently mounted to the exterior of the building at a minimum height of eight (8) feet above grade directly in line with the exhaust vent terminal for the horizontally vented, gas-fueled heating appliance or equipment. The sign shall read, in print size no less than one-half (1/2) inch in size, "GAS VENT DIRECTLY BELOW. KEEP CLEAR OF ALL OBSTRUCTIONS."

- 4 - **INSPECTION.** The state or local gas inspector of the side wall, horizontally vented, gas-fueled equipment shall not approve the installation unless, upon inspection, the inspector observes carbon monoxide detectors and signage installed in accordance with the provisions of 248 CMR 5.08(2)(a) 1 through 4.

#### **EXEMPTIONS: The following equipment is exempt from 24 CMR 5.08(2)(a) 1 through 4:**

- 1 - The equipment listed in Chapter 10 entitled "Equipment Not Required to Be Vented" in the most current edition of NFPA 54 as adopted by the Board; and
- 2 - Product Approved side wall, horizontally vented, gas-fueled equipment installed in a room or structure separate from the dwelling, building or structure used in whole or in part for residential purposes.

#### **MANUFACTURER REQUIREMENTS - GAS EQUIPMENT VENTING SYSTEM PROVIDED.**

When the manufacturer of Product Approved side wall, horizontally vented, gas-fueled equipment provides a venting system design or venting system components with the equipment, the instructions provided by the manufacturer for installation of the equipment and the venting system shall include:

- 1 - Detailed instructions for the installation of the venting system design or the venting system components: and
- 2 - A complete parts list for the venting system design or venting system.

#### **MANUFACTURER REQUIREMENTS - GAS EQUIPMENT VENTING SYSTEM NOT PROVIDED.**

When the manufacturer of Product Approved side wall, horizontally vented, gas-fueled equipment does not provide the parts for venting the flue gases, but identifies "special venting systems," the following requirements shall be satisfied by the manufacturer:

- 1 - The referenced "special venting system" instructions shall be included with the appliance or equipment installation instructions; and
- 2 - The "special venting systems" shall be Product Approved by the Board, and the instructions for that system shall include a parts list and detailed installation instructions.

**A copy of all installation instructions for all Product Approved side wall, horizontally vented, gas-fueled equipment, all venting instructions, all parts lists for venting instructions, and/or all venting design instructions shall remain with the appliance or equipment at the completion of the installation.**