

INSTALLATION INSTRUCTIONS

MULTI-POSITION GAS-FIRED FURNACES INDUCED-DRAFT

Supersedes: 650.69-N3W (394)

650.69-N3W (1294)

035-10959

MODELS: PBKM (Upflow/Horizontal)

40-140 MBH INPUT

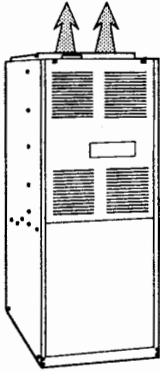

UPFLOW

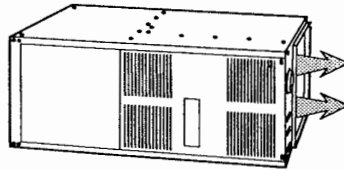

HORIZONTAL (RIGHT)

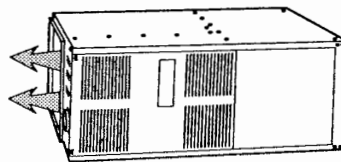

HORIZONTAL (LEFT)

MODELS PBKD (Downflow)

60-130 MBH INPUT

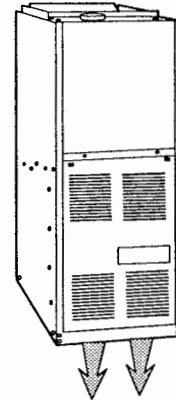

DOWNFLOW



FOR YOUR SAFETY

WHAT TO DO IF YOU SMELL GAS

- Do not try to light any appliance.
- Open windows.
- Do not touch any electrical switch; do not use any phone in your building.
- Extinguish any open flame.
- Immediately call your gas supplier from a neighbor's phone. Follow the gas supplier's instructions.
- If you cannot reach your gas supplier, call the fire department.

CAUTION

THIS PRODUCT MUST BE INSTALLED IN STRICT COMPLIANCE WITH THE ENCLOSED INSTALLATION INSTRUCTIONS AND ANY APPLICABLE LOCAL, STATE, AND NATIONAL CODES INCLUDING BUT NOT LIMITED TO, BUILDING, ELECTRICAL AND MECHANICAL CODES.

WARNING

IMPROPER INSTALLATION MAY CREATE A CONDITION WHERE THE OPERATION OF THE PRODUCT COULD CAUSE PERSONAL INJURY OR PROPERTY DAMAGE.

FOR YOUR SAFETY

Do not store or use gasoline or other flammable vapors and liquids in the vicinity of this or any other appliance.

WARNING: Improper installation, adjustment, alteration, service or maintenance can cause injury or property damage. Refer to this manual. For assistance or additional information, consult a qualified installer, service agency or the gas supplier.

TABLE OF CONTENTS

GENERAL INFORMATION

Description	2
Inspection	2
Notes, Cautions & Warnings	2
Limitations and Locations	2-3
Clearances	3
Nomenclature	3
Dimensions	4-5
Ratings & Physical Data	4-5
Unit Wiring Diagrams	19-20
Blower Performance	21-22

UNIT INSTALLATION

Combustion Air & Vent System	3
Venting	6
Ductwork	6
Filters (Upflow/Horizontal)	7
Upflow Application	7
Horizontal Application	8
Downflow Application	9
Gas Piping	9-10
Electrical Connections	10
Safety Controls	11
Start-Up & Adjustments	11
Ignition System Checkout/Adjustment	11-12
Adjustment of Manifold Gas Pressure	12-13
Checking Gas Input	12
Adjustment of Temperature Rise	13
Adjustment of Fan Off Settings	13
Accessory Connections	13

OPERATION & MAINTENANCE

Sequence of Operation	13-14
Maintenance	14
Air Filters	14
Lubrication	14
Burners	14-15
Heat Exchangers	15
Blower	15
Troubleshooting	15
Control LED Diagnostics	15
Troubleshooting Charts	16-18

GENERAL INFORMATION

DESCRIPTION

This Category I furnace is designed for installation in a residential or commercial application. A Category 1 furnace has a fan assisted combustion system equipped with an integral mechanical means to draw products of combustion through the combustion chamber and heat exchanger. It may be installed in a basement, garage, equipment room, alcove, attic or any other indoor location where all required clearances to combustibles and other restrictions are met. It is designed for natural gas-fired operation, but may be converted to propane (LP).

High altitude and propane (LP) changes or conversions required in order for the appliance to satisfactorily meet the application must be made by an authorized distributor: in Canada, a certified conversion station or other qualified agency, using factory specified and/or approved parts.

Upflow/horizontal (PBKM) furnaces and downflow (PBKD) furnaces may be used only as Category 1 units.

The furnace must be installed so that all electrical components are protected from water.

INSPECTION

As soon as a unit is received, it should be inspected for possible damage during transit. If the damage is evident, the extent of the damage should be noted on the carrier's freight bill.

A separate request for inspection by the carrier's agent should be made in writing. Also, before installation, the unit should be checked for screws or bolts which may have loosened in transit.

NOTES, CAUTIONS & WARNINGS

The installer should pay particular attention to the words: **NOTE**, **CAUTION** and **WARNING**. NOTES are intended to clarify or make the installation easier. CAUTIONS are given to prevent equipment damage. WARNINGS are given to alert the installer that personal injury and/or equipment or property damage may occur if installation procedures are not handled properly.

WARNING: *The furnace area must not be used as a broom closet or for any other storage purposes, as a fire hazard may be created. Never store items such as the following on, near or in contact with the furnace.*

1. *Spray or aerosol cans, rags, brooms, dust mops, vacuum cleaners or other cleaning tools.*
2. *Soap powders, bleaches, waxes or other cleaning compounds; plastic items or containers; gasoline, kerosene, cigarette lighter fluid, dry-cleaning fluids or other volatile fluid.*
3. *Paint thinners and other painting compounds.*
4. *Paper bags, boxes or other paper products.*

WARNING: *Never operate the furnace with the blower door removed. To do so could result in serious personal injury and/or equipment damage.*

WARNING: *Each furnace in this series is a Category I furnace, suitable for common venting with other gas-fired appliances as allowed by the National Fuel Gas Code, NFPA 54/ANSI Z223.1-latest edition.*

WARNING: *This appliance is not to be used for temporary heating of buildings or structures under construction.*

WARNING: *Do not install this furnace in a corrosive or contaminated atmosphere.*

WARNING: *Do not install this furnace in a mobile home or recreational vehicle.*

WARNING: *Furnaces shall not be installed directly on carpeting, tile or other combustible material other than wood flooring.*

LIMITATIONS AND LOCATION

This furnace should be installed in accordance with all national/local building/safety codes and requirements, or in the absence of local codes, with the National Fuel Gas Code, ANSI Z223.1 - (latest edition) or, in Canada, CAN/CGA B149.1 or .2 - (latest edition), and other applicable codes.

Use only the type of gas approved for this furnace; refer to the furnace rating plate.

WARNING: *Only use natural gas in furnaces designed for natural gas. Only use propane (LP) gas for furnaces that have been properly converted to use propane (LP) gas. Do not use this furnace with butane. Using wrong gas could create a hazard, resulting in damage, injury or death.*

For installations above 2,000 feet, reduce input 4% for each 1,000 feet above sea level. Canadian installations must be derated 10% for elevations from 2,000 ft. to 4,500 ft. Accessory high altitude kits are available to properly derate furnace.

In the U.S. only, furnace shall not be connected to a chimney flue serving a separate appliance designed to burn solid fuel.

Check the rating plate and power supply to be sure that electrical characteristics match. All models use nominal 120 vac, 1 Ø, 60 Hz. power supply.

A furnace installed in a residential garage must be located so that all burners and burner ignition devices are located no less than 18" above the garage floor, and located or protected to prevent damage by vehicles.

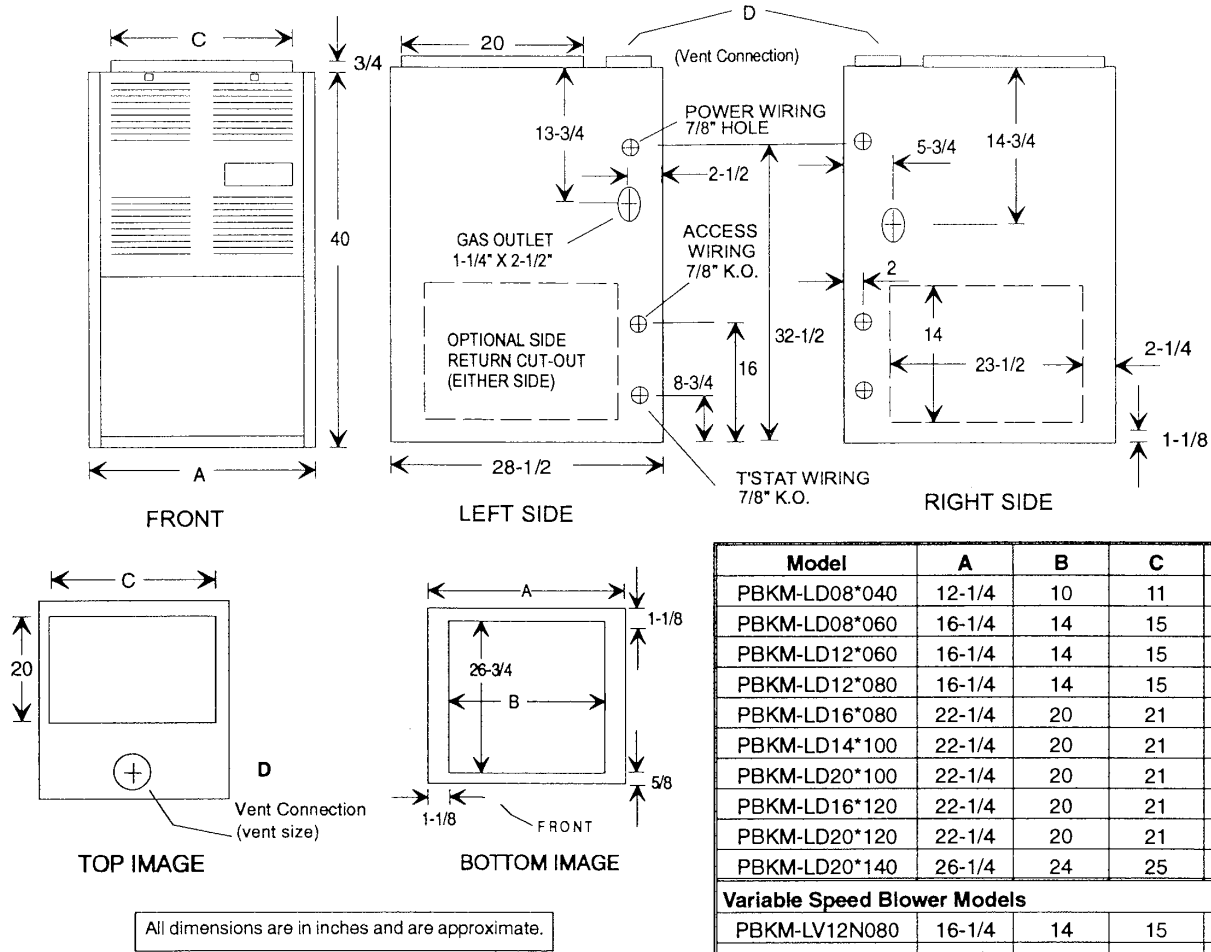

FIGURE 1 - UPFLOW FURNACE DIMENSIONS

TABLE 2 - RATINGS & PHYSICAL/ELECTRICAL DATA

Model	Air Temp Rise °F	Max. Outlet Temp. °F	Blower		Total Unit Amps	Max. Over-Current Breaker	Min. Wire Size (AWG) @ 75 Ft. One Way	Recommended High Velocity Filter Size		Weight (lbs)
			HP	Size				Side	Bottom	
PBKM-LD08*040	10-40	180	1/4	9 x 6	12	15	14	16 X 25	12 X 27	85
PBKM-LD08*060	35-65	180	1/6	10 x 7	12	15	14	16 X 25	16 X 27	98
PBKM-LD12*060	25-55	180	1/2	10 x 7	12	15	14	16 X 25	16 X 27	102
PBKM-LD12*080	25-55	180	1/2	10 x 7	12	15	14	16 X 25	16 X 27	115
PBKM-LD16*080	20-50	180	1/2	10 x 10	12	15	14	16 X 25	20 X 27	119
PBKM-LD14*100	30-60	180	1/2	10 x 9	12	15	14	16 X 25	20 X 27	130
PBKM-LD20*100	30-60	180	3/4	11 x 10	13.8	15	14	16 X 25	20 X 27	135
PBKM-LD16*120	30-60	180	3/4	10 x 9	13.0	15	14	16 X 25	20 X 27	146
PBKM-LD20*120	25-55	180	3/4	11 x 10	13.8	15	14	16 X 25	20 X 27	151
PBKM-LD20*140	35-65	180	3/4	11 x 10	13.8	15	14	16 X 25	25 X 27	163
Variable Speed Blower Models										
PBKM-LV12N080	25-55	180	1/2	10 x 7	12	15	14	16 X 25	16 X 27	119
PBKM-LV14N100	30-60	180	1/2	10 x 9	12	15	14	16 X 25	20 X 27	135
PBKM-LV20N100	30-60	180	1	11 x 10	12	15	14	16 X 25	20 X 27	140

- NOTES: 1. Filters may be provided as an accessory or field supplied. High velocity type must be used
 2. All airflow over 1800 cfm requires return air from both side inlets or bottom
 * Model designator may be "N" for standard units, or "L" for factory built low NOx units. Canadian units offered only as "N" models.

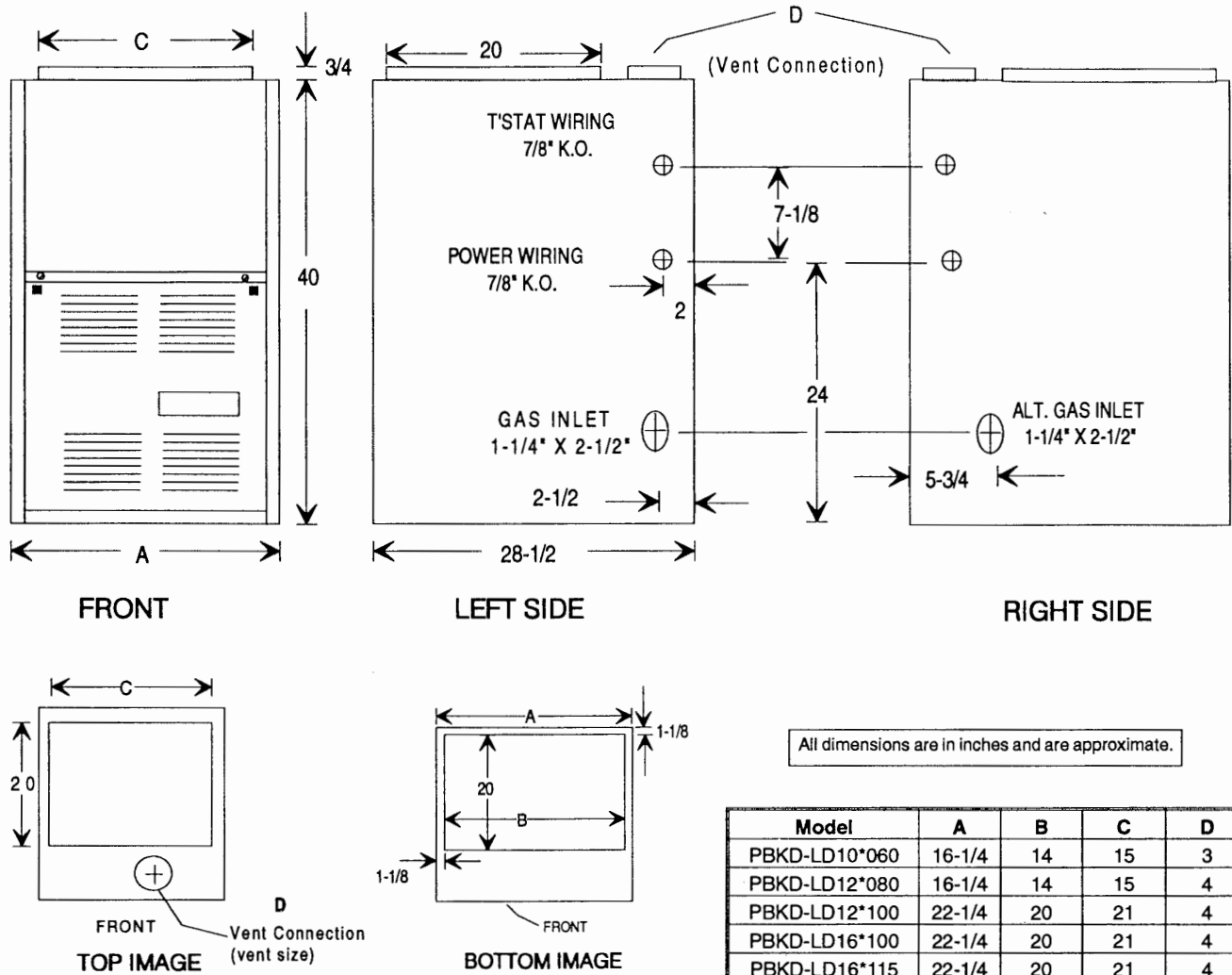

FIGURE 2 - DOWNFLOW FURNACE DIMENSIONS

TABLE 3 - RATINGS & PHYSICAL/ELECTRICAL DATA

Model	Air Temp Rise °F	Max. Outlet Temp. °F	Blower		Total Unit Amps	Max. Over-Current Breaker	Min. Wire Size (AWG) @ 75 Ft. One Way	Recommended High Velocity Filter Size	Weight (lbs)
			HP	Size					
PBKD-LD10*060	35 - 65	165	1/4	10 x 7	12.0	15	14	(2) 14 X 20	105
PBKD-LD12*080	25 - 55	155	1/2	10 x 8	12.0	15	14	(2) 14 X 20	118
PBKD-LD12*100	35 - 65	165	1/2	10 x 10	12.0	15	14	(2) 14 X 20	134
PBKD-LD16*100	30 - 60	160	3/4	11 x 10	13.8	15	14	(2) 14 X 20	140
PBKD-LD16*115	30 - 60	160	3/4	11 x 10	13.8	15	14	(2) 14 X 20	156
PBKD-LD20*130	35 - 65	165	3/4	11 x 10	13.8	15	14	(2) 14 X 20	168

* Model designator may be "N" for standard units, or "L" for factory built low NOx units

The recommended source of combustion air is to use the outdoor air supply. Excessive exposure to contaminated combustion air will result in safety and performance related problems. However, the use of indoor air in most applications is acceptable, except as follows:

1. If the furnace is installed in a confined space it is recommended that the necessary combustion air come from the outdoors by way of attic, crawl space, air duct or direct opening.
2. If outdoor combustion air is used, there must be no exposure to the installations or substances listed in "3" below.
3. The following types of installations may require OUTDOOR AIR for combustion, due to chemical exposure.
 - a) Commercial buildings
 - b) Buildings with indoor pools
 - c) Furnaces installed in laundry rooms
 - d) Furnaces installed in hobby or craft rooms
 - e) Furnaces installed near chemical storage areas

Exposure to the following substances in the combustion air supply may also require OUTDOOR AIR for combustion.

- f) Permanent wave solutions
- g) Chlorinated waxes and cleaners
- h) Chlorine based swimming pool chemicals
- i) Water softening chemicals
- j) De-icing salts or chemicals
- k) Carbon tetrachloride
- l) Halogen type refrigerants
- m) Cleaning solvents (such as perchloroethylene)
- n) Printing inks, paint removers, varnishes, etc.
- o) Hydrochloric acids
- p) Cements and glues
- q) Antistatic fabric softeners for clothes dryers
- r) Masonry acid washing chemicals

VENTING

CATEGORY I VENTING

Category I venting consists of vertically venting one or more appliances in single wall, B-vent or masonry chimney (as allowed), using single wall metal pipe or B-vent connectors.

NOTE: This appliance may be common vented with another gas appliance as allowed by the following codes and standards.

The furnace rating plate lists the maximum vent gas temperature. This temperature must be used to select appropriate venting materials and clearances. A typical example is shown below.

"CATEGORY 1/450° F. MAX. VENT TEMP."

All installations must be vented in accordance with the National Fuel Gas Code, NFPA 54/ANSI Z223.1 - latest edition. For reference, the National Fuel Gas Code Handbook, available from NFPA (item JP-54HB92) is recommended. The appliance must also be vented in compliance with all local utility and code requirements. In Canada, the furnace must be vented in accordance with the National Standard of Canada, CAN/CGA-B149.1 and .2 - latest editions.

WARNING

It is the responsibility of the installer to verify proper vent system operation.

WARNING: A furnace shall not be connected to a chimney flue serving a separate appliance designed to burn solid fuel.

VENT SAFETY CHECK PROCEDURE

WARNING: If this furnace is replacing a common-vented furnace, it may be necessary to resize the existing vent line and chimney to prevent oversizing problems for the new combination of units. Refer to the National Fuel Gas Code,

ANSI Z223.1 or CAN/CGA B149.1 or .2 Installation Code - latest editions.

The following steps shall be followed with each appliance connected to the venting system placed in operation, while any other appliances connected to the common venting system are not in operation.

1. Seal any unused openings in the common venting system.
2. Inspect venting system for proper size and horizontal pitch, as required in the National Fuel Gas Code ANSI Z223.1 or the CAN/CGA B149 Installation Codes and these instructions. Determine that there is no blockage or restriction, leakage, corrosion or other deficiencies which could cause an unsafe condition.
3. Insofar as is practical, close all building doors and windows and all doors between the space in which the appliance(s) connected to the venting system are located and other spaces of the building. Turn on clothes dryers and any other appliances not connected to the common venting system. Turn on any clothes dryers and any appliance not connected to the venting system. Turn on any exhaust fans, such as range hoods and bathroom exhausts so they will operate at maximum speed. Do not operate a summer exhaust fan. Close fireplace dampers.
4. Follow the lighting instructions. Place the appliance being operated in operation. Adjust thermostat so appliance will operate continuously.
5. Test for draft hood equipped appliance spillage at the draft hood relief opening after 5 minutes of main burner operation. Use the flame of a match or candle.
6. After it has been determined that each appliance connected to the venting system properly vents when tested as outlined above, return doors, windows, exhaust fans, fireplace dampers and any other gas-burning appliance to their previously conditions of use.
7. If improper venting is observed during any of the above tests, the venting system must be corrected.
8. Any corrections or resizing of the common venting system must be in accordance with the National Fuel Gas Code, ANSI Z223.1 or Section 7, Venting Systems and Air Supply for Appliances, CAN/CGA B149.1 or .2 Installation Code - latest editions. If the common vent system must be resized, it should be resized to approach the minimum size as determined using the appropriate tables in Appendix G of the above codes or the venting tables supplied with the furnace.

DUCTWORK

The duct system's design and installation must:

1. Handle an air volume appropriate for the served space and within the operating parameters of the furnace specifications.
2. Be installed in accordance with standards of NFPA (National Fire Protection Association) as outlined in NFPA pamphlets 90A and 90B (- latest editions).
3. Create a closed duct system. The supply system must be connected to the furnace outlet and the return duct system must be connected to the furnace inlet. Both supply and return duct systems must terminate outside the space containing the furnace.
4. Generally complete a path for heated or cooled air to circulate through the air conditioning and heating equipment and to and from the conditioned space.

CAUTION: The cooling coil must be installed in the supply air duct downstream of the furnace.

When the furnace is used in conjunction with a cooling coil, the furnace must be installed parallel with, or on the upstream side of the cooling unit to avoid condensation in the primary heat exchanger.

When a parallel flow arrangement is used, the dampers or other means used to control air flow must be adequate to prevent chilled air from entering the furnace, and if manually operated, must be equipped with means to prevent operating of either unit unless the damper is in the full heat or cool position.

UPFLOW APPLICATION

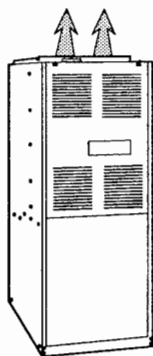

Supply Plenum Connection

Attach the supply plenum to the furnace outlet duct connection flanges. This is typically through the use of "S" cleat material when a metal plenum is used. The use of an approved flexible duct connector is recommended on all installations. This connection should be sealed to prevent air leakage.

If a matching cooling coil is used, it may be placed directly on the furnace outlet and sealed to prevent leakage. Follow

the coil instructions for installing the supply plenum.

On all installations a removable access panel should be provided in the outlet duct such that smoke or reflected light would be observable inside the casing to indicate the presence of leaks in the heat exchanger. This access cover shall be attached in such a manner as to prevent leaks.

Return Duct Connection

Return air may enter the furnace through the side(s) or bottom depending on the type of application. See the specific type application installation for details. Be sure to see the "Filters" section of this instruction.

FILTERS (UPFLOW/HORIZONTAL)

All applications require the use of a filter. This may be through the use of any of the following accessory or field supplied methods:

- Internal Side Filter With Retainer - 1BF0302 (Upflow)**
This provides a cleanable, high velocity type filter and retainer hardware for mounting inside the furnace cabinet.
- External Side Return Filter Rack - 1SR0301. (Upflow)**
This provides a 16x25 cleanable, high velocity type filter and attaches to the furnace side panel and the return air duct. The filter may be easily replaced.
- Internal Mount Bottom Return Filter Accessory (Upflow) - 1BF0301-304** This provides a cleanable, high velocity type filter and retainer hardware for mounting inside the furnace cabinet. This type filter requires removing the furnace blower compartment cover to change the filter.
- External Bottom Return/End Return Horizontal, Filter Rack Accessory - 1HF0301-304** Provides a cleanable, high velocity type filter and rack. Attaches to the end of the furnace and provides duct flanges.
- Field Supplied Filter and Mounting System.**
A return air filter grille or duct mounted filter may be provided. The following minimum sizes are recommended.

RECOMMENDED SIZE FOR FIELD SUPPLIED HIGH VELOCITY FILTERS		
Furnace CFM	FILTER	
	Size	Sq. inches
800	12 x 27	300
1200	16 x 27	400
1600	20 x 27	500
2000	25 x 27	625

NOTE: Air velocity through throw-away type filters may not exceed 300 feet per minute. All velocities over this require the use of high velocity filters.

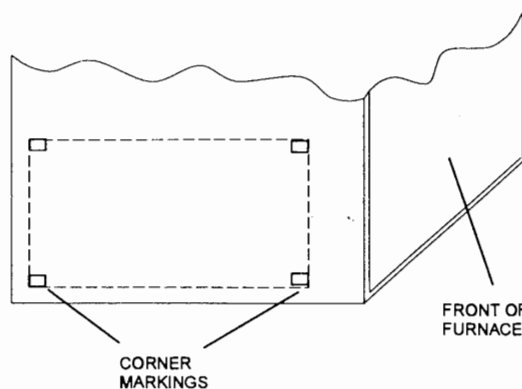

FIGURE 4 - SIDE RETURN CUTOUT MARKINGS

Side Return

Locate and knock out the square corner locaters. These indicate the size of the cutoff to be made in the furnace side panel (see Figure 4).

Install the side filter rack following the instructions provided with that accessory. If a filter(s) is provided at another location in the return air system, the ductwork may be directly attached to the furnace side panel.

NOTE: Some accessories such as electronic air cleaners and pleated media may require a larger side opening.

CAUTION: All installations must have a filter installed.

The return duct may be attached to the furnace by "S-cleat", bend tabs or other approved methods. Be sure to seal the duct to the furnace to prevent air leakage.

Those applications over 1800 CFM require either return from two sides, or bottom.

Where the return duct system is not complete, the return connection must run full size to a location outside the utility room or basement. For further details, consult Section 5.3 (Air for Combustion and Ventilation) of the National Fuel Gas Code, ANSI Z223.1, or CAN/CGA B149.1 or .2, Installation Code - latest editions.

Bottom Return

Converting the furnace to open bottom return requires removing the bottom closure plate. Use the following steps.

- Remove the upper access door and blower compartment door.

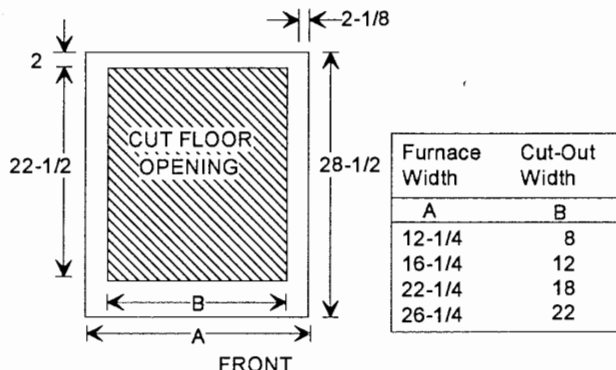

FIGURE 5- BOTTOM RETURN (COMBUSTIBLE FLOOR)

2. Remove the four screws securing the front bottom angle and remove it from the unit. Keep the angle for reinstallation.
3. Remove the screws from the furnace wrapper which secure the bottom closure panel and remove the panel from the blower compartment by pulling it forward and tilting upward.
4. Reinstall the front bottom angle and access doors.

Bottom return applications normally pull return air through a base platform or return air plenum. Refer to Figure 5 for opening dimensions. Be sure the return platform structure is suitable to

support the weight of the furnace. Seal the furnace to the plenum to prevent air leakage.

NOTE: If an external mounted filter rack is being used, see the instructions provided with that accessory for proper hole cut size.

Upflow attic installations must meet all minimum clearances to combustibles and have floor support with required service accessibility.

HORIZONTAL APPLICATION - PBKM MODELS ONLY

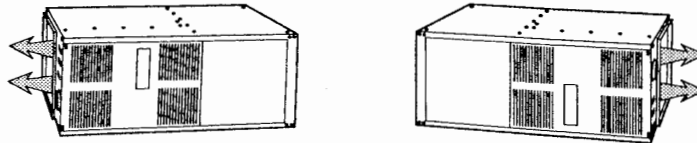

UPFLOW/HORIZONTAL MODELS

Upflow furnaces may be installed horizontally with the supply airflow toward the left or right by laying the unit on the left or right panel. **Do not install the unit on the rear panel.** After determining the best orientation, lay the unit on top of the shipping carton to protect the finish.

The appropriate electrical knock-outs for power wiring, control wiring and gas piping should be removed at this time.

When in the horizontal position, return air may enter through the end of the unit, the bottom panel, the top panel or any combination of these openings. Return air may not be connected into the rear panel of the unit.

To convert the upflow model furnace to open bottom, refer to the Upflow Application - Bottom Return section of this manual and follow steps 1 thru 4 to remove the bottom closure panel.

This line may be in contact with combustible material. However, refer to "Venting" and "Clearances" in this manual for additional information.

Secure a platform constructed of plywood or other building material to the floor joists. Sheet metal, 12" in front of the furnace is required. Refer to Figure 6 for details.

WARNING: When a furnace is installed in an attic or other insulated space, keep all insulating materials at least 12" away from furnace and burner combustion air openings.

CRAWL SPACE INSTALLATION

The furnace can be hung from floor joists or installed on suitable blocks or pad. Blocks or pad installations shall provide adequate height to ensure the unit will not be subject to water damage.

When suspending the furnace from rafters or floor joists using rod, pipe or straps, refer to Physical Data (Page 4) for furnace weights to determine suitable means of suspension. Angle supports should be placed at the supply air end and near the blower deck. Units may also be suspended by using straps or other material at the same location. All four suspension points must be level to ensure quiet furnace operation.

ATTIC INSTALLATION

This appliance is design certified for line contact for furnaces installed horizontally. The intersection of the furnace top and sides form a line.

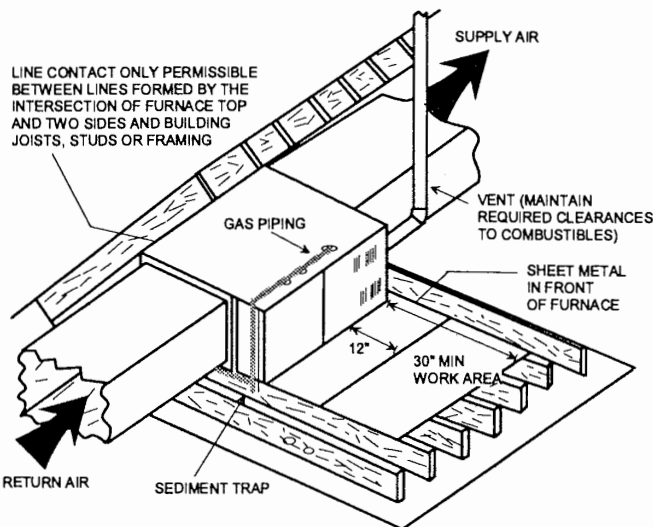

FIGURE 6 - TYPICAL ATTIC INSTALLATION

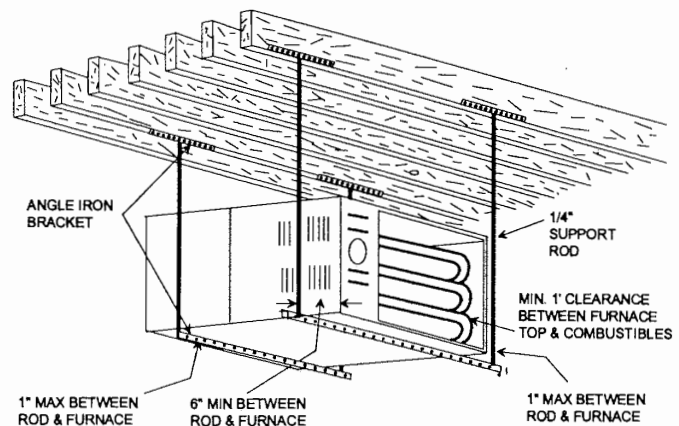
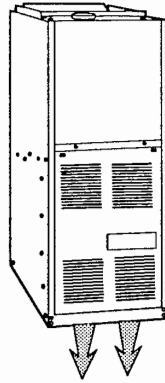

FIGURE 7 - TYPICAL FURNACE INSTALLATION USING SUSPENSION MATERIALS

DOWNFLOW APPLICATION



DOWNFLOW FILTERS

A top return filter rack is supplied with the furnace. Two 14" x 20" permanent washable filters are supplied with each unit. Refer to Downflow Application for details.

Downflow furnaces typically are installed with the filters located above the furnace, extending into the return air duct. An alternate method is detailed in the Filters (Upflow/Horizontal) sections, Step 4. The branch duct must attach to the vertical ductwork above the filter height (FH) in Figure 8. Refer to dimensions in Figure 8 for proper installation.

The filter rack (provided) should be secured to the center of the front and rear flanges at the furnace top. Drill a hole through the front and rear duct flange into the filter rack and secure it with a sheet metal screw.

Refer to the unit rating plate for furnace model then see the dimensions page of this instruction for return air plenum dimensions. Install the plenum following instructions under Ductwork in this instruction.

SUPPLY AIR DUCTS

Installations on combustible material or floors must use a combustible floor base (shown in Figure 9 - 1FB0302-304) as specified on the rating plate or a matching cooling coil.

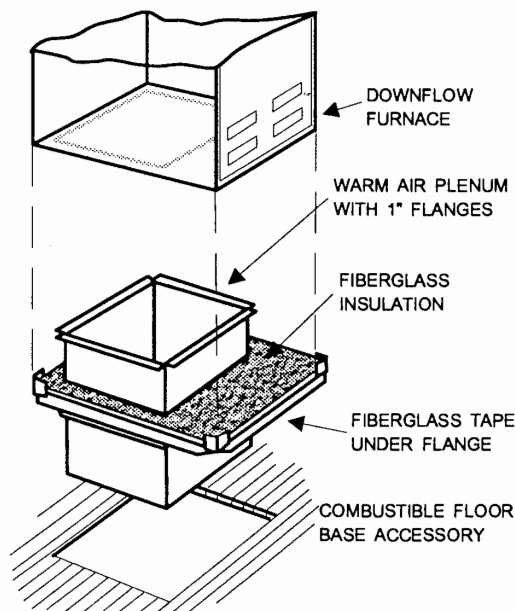

FIGURE 9 - COMBUSTIBLE FLOOR BASE ACCESS'Y

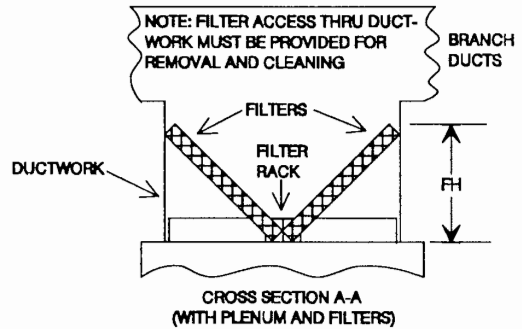
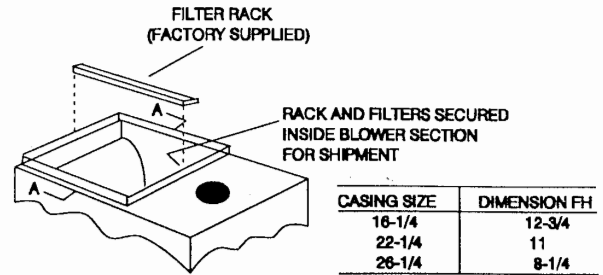

FIGURE 8 - DOWNFLOW FILTERS

Follow the instructions with the combustible floor base accessory. The floor opening dimensions for the floor base are shown in Figure 10.

This base can be replaced with a matching cooling coil, properly sealed to prevent leaks. Follow the cooling coil instructions for installing the plenum.

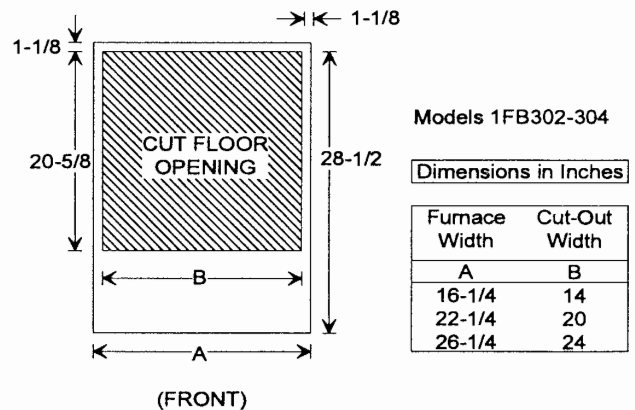

FIGURE 10 - FLOOR BASE ACCESSORY BOTTOM SUPPLY OPENING

GAS PIPING

NOTE: An accessible manual shutoff valve must be installed upstream of the furnace gas controls and within 6 feet of the furnace. A 1/8" NPT plugged tapping, accessible for test gauge connection, should be installed immediately upstream of the gas supply connection to the furnace.

The furnace and its individual shutoff valve must be disconnected from the gas supply piping system during any pressure testing of that system at test pressures in excess of 1/2 psig (3.48 kPa).

The furnace must be isolated from the gas supply piping system by closing its individual external manual shutoff valve during any pressure testing of the gas supply piping system at test pressures equal to or less than 1/2 psig (3.48 kPa).

CAUTION: Never apply a pipe wrench to the body of the combination automatic gas valve. A wrench must be placed on the projection or wrench boss of the valve when installing piping to it.

Gas piping may be connected from either side of the furnace. Sizing and installation of the supply gas line should comply with the local utility requirements.

The gas supply should be a separate line, installed in accordance with the National Fuel Gas Code, ANSI Z223.1, or CAN/CGA B149.1 or .2 Installation Codes - (latest editions).

Some utility companies, or local codes, require pipe sizes larger than the minimum sizes listed. Using the properly sized wrought iron, approved flexible or steel pipe, make gas connections to the unit. Installation of a drop leg and ground union is required (See Figure 11).

INLET GAS PRESSURE RANGE		
	Natural Gas	Propane (LP)
Minimum	4.5 In. W.C.	11 In. W.C.
Maximum	13.8 In. W.C.	13.8 In. W.C.

WARNING: Compounds used on threaded joints of gas piping must be resistant to the action of liquified petroleum gases.

WARNING: After all gas piping connections are completed, leak test all joints, fittings and furnace connections with rich soap and water solution, commercial available bubble type leak detection fluid, or other approved means.

WARNING: Do not use an open flame or other source of ignition for leak testing.

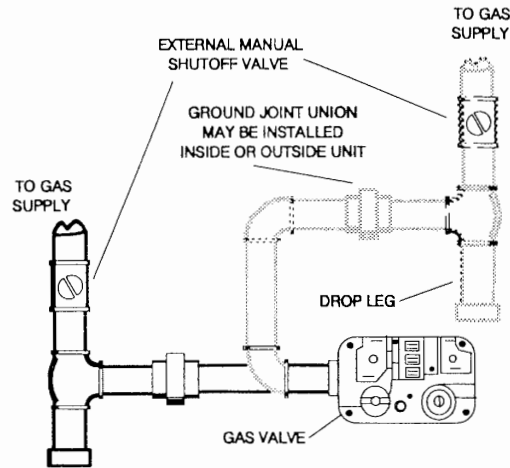

FIGURE 11 - GAS PIPING

ELECTRICAL POWER CONNECTION

Field wiring to the unit must conform to and be grounded in accordance with the provisions of the National Electrical Code ANSI/NFPA No. 70 -latest edition, Canadian Electric Code C22.1 Part 1 - (latest edition) and/or local codes. Electrical wires which are field installed shall conform with the temperature limitation for 63°F/35°C rise wire when installed in accordance with instructions. Specific electrical data is given on the furnace rating plate.

Provide a power supply separate from all other circuits. Install overcurrent protection and disconnect switch per local/national electrical codes. The switch should be reasonable close to the unit for convenience in servicing. With the disconnect switch in the OFF position, check all wiring against the unit wiring label. Also, see the wiring diagram in this instruction.

Use copper conductors only.

CAUTION: Do not pull the lead to the HSI during the power wiring process. Pulling lead will damage the HSI.

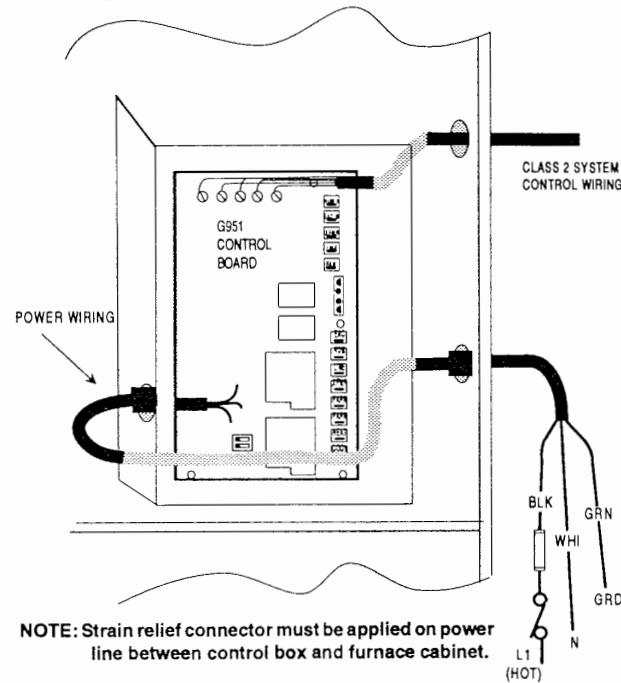
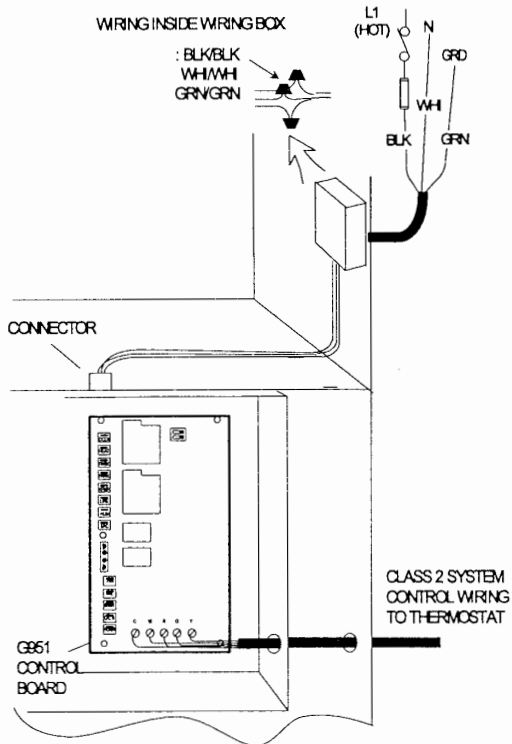

NOTE: Strain relief connector must be applied on power line between control box and furnace cabinet.

NOTE: Canadian installations must have flexible conduct to protect power wiring between furnace jacket and control box.

FIGURE 12 - POWER/CONTROL WIRING (Upflow Models -left, Downflow Models - right)

NOTE: The furnace's control system depends on correct polarity of the power supply.

Connect the power supply as shown on the unit wiring label on the inside of the blower compartment door and Figure 12. The black furnace lead must be connected to the L1 (hot) wire from the power supply. The white furnace lead must be connected to neutral. Also, the green equipment ground wire must be connected to the power supply ground.

Remove the screw retaining the wiring box. Route the power wiring through the unit side panel with a conduit connector or other proper connection. Make wiring connections as shown in Figure 12. Replace the wiring box and screw.

An alternate wiring method is to use a field provided 2 x 4 box and cover on the outside of the furnace. Route the furnace leads into the box using a protective bushing where the wires pass through the furnace panel.

NOTE: The power connection leads and wiring box on upflow units may be relocated to the left side of the furnace. Remove the screw and slide box and wires under manifold bracket. Reposition on the left side of the furnace and fasten to blower deck using hole provided.

ELECTRICAL CONTROL CONNECTIONS

Install the field-supplied thermostat. The thermostat instructions for wiring are packed with the thermostat. With the thermostat set in the OFF position and the main electrical source disconnected, complete the low-voltage wiring from the thermostat to the terminal board on the low-voltage transformer. Connect Class 2 control wiring as shown in Figures 12 and 13.

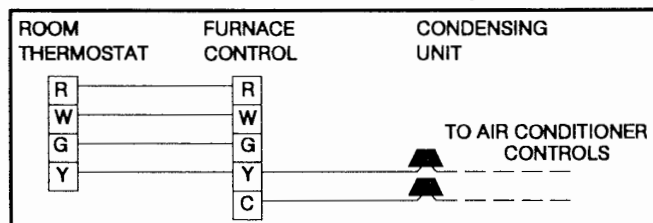

FIGURE 13 - TYPICAL HEATING AND COOLING

Set the heat anticipator in the room thermostat to .45 amps. Setting it lower will cause short cycles. Setting it higher will cause the room temperature to exceed the setpoint.

NOTE: Some electronic thermostats do not have adjustable heat anticipators. They may have other type cycle rate adjustments. Follow the thermostat manufacturer's instructions.

The 24-volt, 40 VA transformer is sized for the furnace components only, and should not be connected to auxiliary devices such as humidifiers, air cleaners, etc. The transformer may provide power for an air conditioning unit contactor.

SAFETY CONTROLS

Blower Door Safety Switch

This unit is equipped with an electrical interlock switch mounted in the blower compartment. This switch interrupts all power at the unit when the panel covering the blower compartment is removed.

WARNING: Blower and burner must never be operated without the blower panel in place.

Electrical supply to the unit is dependent upon the panel that covers the blower compartment being in place and properly positioned

Unitary Products Group

CAUTION: Main power supply to the unit must still be interrupted at the main power disconnect switch before any service or repair work is to be done to the unit. Do not rely upon the interlock switch as a main power disconnect.

Rollout Switch Controls

These controls are mounted on the burner assembly. If the temperature in the burner compartment exceeds its set point, the igniter control and the gas valve are de-energized. This is a manual reset control and must be reset before operation can continue. The operation of this control indicates a malfunction in the combustion air blower or a blocked vent pipe connection.

Pressure Switch

This furnace is supplied with a differential pressure switch which monitors the flow through the furnace and venting system. This switch de-energizes the ignition control module and the gas valve if any of the following conditions are present:

1. Blockage of internal flue gas passageways.
2. Blockage of vent piping.
3. Failure of combustion air blower/motor.

Limit Control

There is a high temperature limit control located on the furnace vestibule panel just to the right and above the gas valve. This is an automatic reset control and provides over temperature protection due to reduced airflow, such as a dirty filter.

Auxiliary Limit Controls

These high temperature limit controls are located in the blower compartment, one on each side. These are manual reset controls and give high temperature protection when the unit is applied in the horizontal position.

START-UP AND ADJUSTMENTS

The initial start-up of the furnace requires the following additional procedures.

1. When the gas supply is initially connected to the furnace, the gas piping may be full of air. In order to purge this air, it is recommended that the ground joint union be loosened until the odor of gas is detected. When gas is detected, immediately retighten the union and check for leaks. Allow five minutes for any gas to dissipate before continuing with the start-up procedure.
2. All electrical connections made in the field and in the factory should be checked for proper tightness.

IGNITION SYSTEM CHECKOUT/ADJUSTMENT

1. Turn the gas supply ON at external valve and main gas valve.
2. Set the thermostat above room temperature to call for heat.
3. System start-up will occur as follows:
 - a. The venter motor will start and come up to speed. Shortly after venter start-up, the hot surface igniter will glow for about 31 seconds.
 - b. After this warm-up cycle, the ignition module will energize (open) the main gas valve for seven seconds.

NOTE: Furnace may be equipped with either a G951ADB or G951EDB control. On units equipped with the EDB control the hot surface igniter will begin to glow prior to the inducer motor being energized.

NOTE: Burner ignition may not be satisfactory on first start-up due to residual air in gas line, or until gas pressure (manifold) is adjusted.

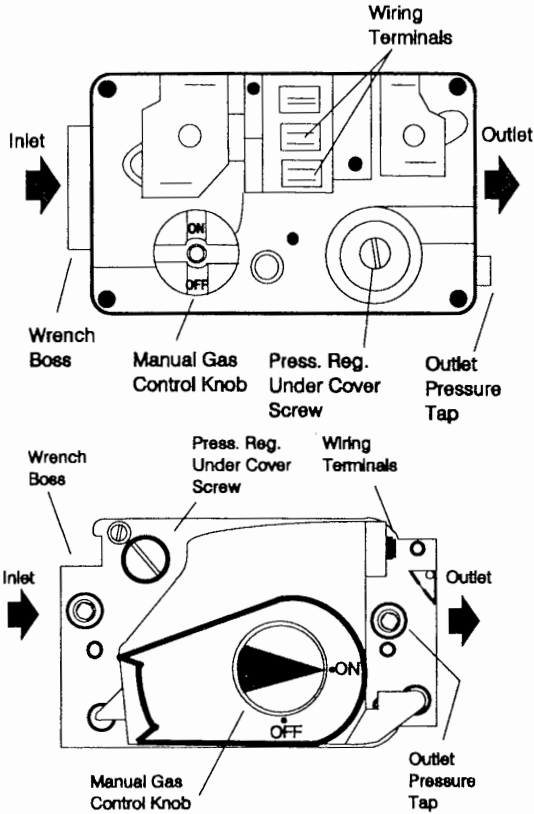

FIGURE 14 - GAS VALVES
 TOP - WHITE-RODGERS 36E97
 BOTTOM - HONEYWELL VR8205

TABLE 4 - GAS RATE (Cubic Feet Per Hour)

Seconds for One Revolution	Size of Test Dial	
	1/2 cubic foot	1 cubic foot
10	180	360
12	150	300
14	129	257
16	113	225
18	100	200
20	90	180
22	82	164
24	75	150
26	69	138
28	64	129
30	60	120
32	56	113
34	53	106
36	50	100
38	47	95
40	45	90
42	43	86
44	41	82
46	39	78
48	37	75
50	36	72
52	35	69
54	34	67
56	32	64
58	31	62
60	30	60

- With the furnace in operation, paint the pipe joints and valve gasket lines with a rich soap and water solution. Bubbles indicate a gas leak. Take appropriate steps to stop the leaks. If the leak persists, replace the component.

WARNING: DO NOT omit this test! NEVER use a flame to check for gas leaks.

CHECKING GAS INPUT

- Turn off all other gas appliances connected to gas meter.
- With the furnace turned on, measure the time needed for one revolution of the hand on the smallest dial on the meter. A typical domestic gas meter usually has a 1/2 or 1 cubic foot test dial.
- Using the number of seconds for each revolution and the size of the test dial increment, find the cubic feet of gas consumed per hour from Table 4.

NOTE: To find the Btuh input, multiply the number of cubic feet of gas consumed per hour by the BTU content of the gas in your particular locality. Contract your gas company for this information, as it varies widely from city to city.

EXAMPLE: It is found by measurement that it takes 26 seconds for the hand to turn on the 1 cubic foot dial to make a revolution with only a 120,000 Btuh furnace running. Using this information, locate 26 seconds in the first column of Table 3.

Read across to the column headed "1 Cubic Foot" where you will see that 138 cubic feet of gas per hour are consumed by the furnace at that rate. Multiply 138 by 850 (the BTU rating of the gas obtained from the local gas company). The result is 117,300 Btuh, which is close to the 120,000 Btuh rating of the furnace.

If the actual input is not within ± 2% of the furnace rating, with allowance being made for the permissible range of the regulator setting (0.3 inches W.C.), replace the orifice spuds with spuds of the proper size.

CAUTION: Be sure to relight any gas appliances that were turned off at the start of this input check.

ADJUSTMENT OF MANIFOLD GAS PRESSURE

- Turn gas off at main gas valve. Remove 1/8" plug in the main gas valve body and install proper manometer tube adapter fitting. Connect line from gas valve tap to manometer.
- Refer to Figure 14 for location of pressure regulator adjustment cap and screw on main gas valve.

NOTE: The screw-off cap for the pressure regulator must be removed entirely to gain access to the adjustment screw.

WARNING: The cap must be replaced in order for the furnace to operate properly.

- Turn gas and electrical supplies ON. Start furnace and observe manifold pressure on manifold.
- Adjust manifold pressure by adjusting gas valve regulator screw.

Natural Gas	3.5" W.C.
Propane (LP)	10.0" W.C.

If gas valve regulator is turned in, or clockwise, manifold pressure is increased. If screw is turned out, or counterwise, manifold pressure will decrease.

WARNING: The manifold pressure must be checked with the screw-off cap in place on the pressure regulator.

WARNING: If manifold pressure is too high, an over-fire condition exists which could cause heat exchanger failure. If the manifold pressure is too low, sooting and eventual clogging of the heat exchanger could occur.

5. Once the correct gas pressure to the burners has been established, turn the gas valve knob to OFF and turn the electrical supply switch OFF; then, remove the pressure tap at the gas valve and re-install the plug using a compound (on the threads) resistant to the action of LP gases.
6. Turn the electrical and gas supplies back on, and, with the burners in operation, check for gas leakage around the plug with a soap and water solution.

WARNING: Be sure that the gas valve pressure regulator cap is replaced.

ADJUSTMENT OF TEMPERATURE RISE

The temperature rise, or temperature difference between the return air and the heated air from the furnace, must be within the range shown on the furnace rating plate and within the application limitations shown in Table 1. After the temperature rise has been determined, the cfm can be calculated.

After about 20 minutes of operation, determine the furnace temperature rise. Take readings of both the return air and the heated air in the ducts, about six feet from the furnace where they will not be affected by radiant heat.

Increase the blower speed to decrease the temperature rise; decrease the blower speed to increase the rise.

All direct-drive blowers have multi-speed motors. The blower motor speed taps are located in the control box in the blower compartment. Refer to Figure 15 and the unit wiring label to change the blower speed.

You may select a heating speed and a cooling speed. They may be the same speed or a different speed.

To use the same speed tap for heating and cooling, the "heat" terminal and "cool" terminal must be connected using a jumper wire and connected to the desired motor lead. Place all unused motor leads on "Park" terminals. Two are provided.

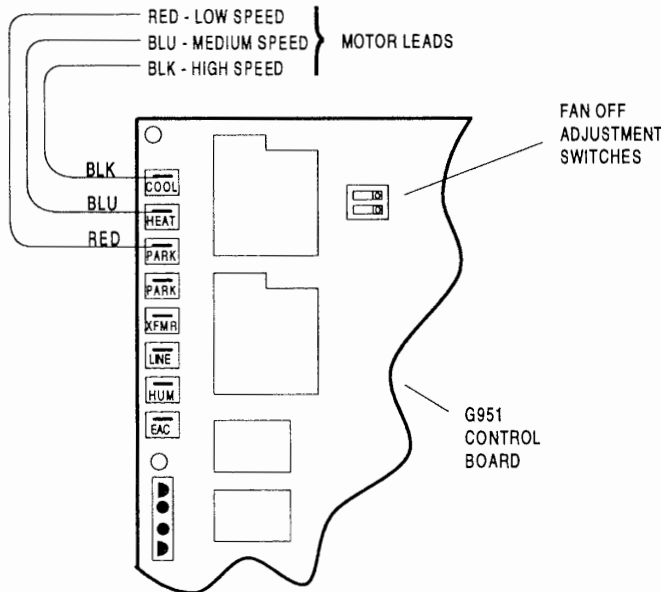

FIGURE 15 - TYPICAL HEAT/COOL SPEED TAP CONNECTIONS

CAUTION: Do not energize more than one motor speed at a time or damage will result.

ADJUSTMENT OF FAN-OFF CONTROL SETTINGS

This furnace is equipped with a time on/time off heating fan control. The fan "on" is fixed at 30 seconds. The fan "off" is field adjustable from 60 to 180 seconds. The fan "off" is factory set to 90 seconds.

The fan-off setting must be long enough to adequately cool the furnace, but not so long that cold air is blown into the heated space. The fan-off timing may be adjusted by setting the option switches located (refer to Figure 14) on the Johnson Controls G951ADB control board as follows:

To Delay Fan-Off By:	Set Switch	
	1	2
60 Sec.	On	On
90 Sec.	On	Off
120 Sec.	Off	On
180 Sec.	Off	Off

ACCESSORY CONNECTIONS

The furnace control will allow power switching control of various accessories. See Figure 16 for connection details.

Electronic Air Cleaner Connection

Two 1/4" spade terminals (AC and AC N) for electronic air cleaner connections are located on the control board. The terminals provide 120 VAC (1.0 amp maximum) during circulating blower operation.

Humidifier Connection

Two 1/4" spade terminals (HUM and HUM N) for humidifier connections are located on the control board. The terminals provide 120 VAC (1.0 amp maximum) during heat speed operation of the circulating blower.

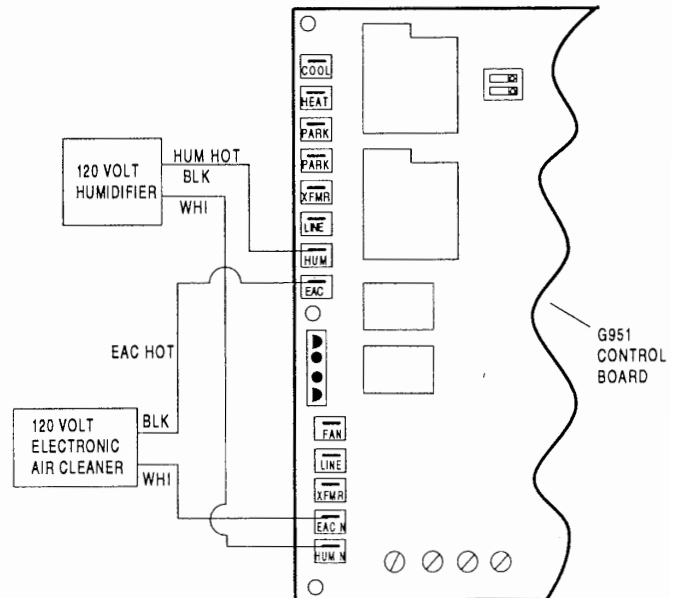

FIGURE 16 - ACCESSORY CONNECTIONS

OPERATION AND MAINTENANCE

SEQUENCE OF OPERATION

The following describes the sequence of operation of the furnace. Refer to the schematic wiring diagram (page 19) for component location.

CONTINUOUS BLOWER

On cooling/heating thermostats with fan switch, when the fan switch is set in the "ON" position, a circuit is completed between terminals R and G of the thermostat. The blower motor is energized through the cool fan terminal and runs on the selected speed.

INTERMITTENT BLOWER - COOLING

On cooling/heating thermostats with fan switch, when the fan switch is set in the "auto" position and the thermostat calls for cooling, a circuit is completed between the R, Y and G terminals. The motor is energized through the cool fan terminal and runs on the selected speed. The fan off setting is fixed at 60 seconds for SEER enhancement.

HEATING CYCLE

NOTE: Furnace may be equipped with either a G951ADB or G951EDB control. On units equipped with the EDB control the hot surface igniter will begin to glow prior to the inducer motor being energized.

CAUTION: Label all wires prior to disconnecting when servicing controls. Wiring errors can cause improper and dangerous operation. Verify proper operation after servicing.

When the system switch is set on HEAT and the fan is set on AUTO, and the room thermostat calls for heat, a circuit is completed between terminals R and W of the thermostat. When the proper amount of combustion air is being provided, a pressure switch activates the ignition control

The ignition control provides a 31-second warm-up period. The gas valve then opens for seven seconds.

As gas starts to flow and ignition occurs, the flame sensor begins its sensing function. If a flame is detected within seven seconds after ignition, normal furnace operation continues until the thermostat circuit between R and W is opened. After flame is present for 30 seconds, the circulating blower is energized.

When the thermostat circuit opens, the G951ADB ignition control is deenergized. With the ignition control deenergized, the gas flow stops and the burner flames are extinguished. The venter continues to operate for 15 seconds after the gas flow stops.

The blower motor continues to operate for the amount of time set by the fan-off delay dip switches located on the G951ADB control board. The heating cycle is then complete, and the unit is ready for the start of the next heating cycle.

If flame is not detected within the seven second sensing period, the gas valve is deenergized. The G951ADB control is equipped with a re-try option. This provides a 60 second wait following an unsuccessful ignition attempt (flame not detected).

After the 60 second wait, the ignition sequence is restarted with an additional 10 seconds of igniter warm-up time. If this ignition attempt is unsuccessful, one more re-try will be made before lockout.

A momentary loss of gas supply, flame blowout, or a shorted or open condition in the flame probe circuit will be sensed within 0.8 seconds. The gas valve will deenergize and the control will restart the ignition sequence after waiting 60 seconds. Recycles will begin and the burner will operate normally if the gas

supply returns, or the fault condition is corrected prior to the last ignition attempt. Otherwise, the control will lockout.

The G951ADB control will repeat the ignition sequence for a total of four recycles if flame is lost within the first 10 seconds of establishment.

If flame is established for more than 10 seconds after ignition, the G951ADB control will clear the ignition attempt (retry) counter. If flame is lost after 10 seconds, it will restart the ignition sequence. This can occur a maximum of five times.

During burner operation, a momentary loss of power of 50 milliseconds or longer will drop out the main gas valve. When the power is restored, the gas valve will remain deenergized and a restart of the ignition sequence will begin immediately.

Hot Surface Ignition System

WARNING: Do not attempt to light this furnace by hand (with a match or any other means). There may be a potential shock hazard from the components of the hot surface ignition system. The furnace can only be lit automatically by its hot surface ignition system.

MAINTENANCE

Air Filters

The filters should be checked periodically for dirt accumulation. Dirty filters greatly restrict the flow of air and overburden the system.

Clean the filters at least every three months. See the section titled "Filters" for filter removal instructions. On new construction, check the filters every week for the first four weeks. Inspect the filters every three weeks after that, especially if the system is running constantly.

All filters used with the furnace are the high-velocity, cleanable type. Clean these filters by washing in warm water. Make sure to shake all the water out of the filter and have it reasonably dry before installing it in the furnace. When replacing filters, be sure to use the same size and type as originally supplied.

Lubrication

Blower motors in these furnaces are permanently lubricated and do not require periodic oiling.

BLOWER CARE

Even with good filters properly in place, blower wheels and motors will become dust laden after long months of operation. The entire blower assembly should be inspected annually. If the motor and wheel are heavily coated with dust, they can be brushed and cleaned with a vacuum cleaner.

The procedure for removing the direct drive blower assembly for cleaning is as follows:

1. Disconnect the electrical supply to the furnace.
2. Remove the access panels.
3. Disconnect the two wire harness plugs from the top of the control box.
4. Remove the four screws holding the control box and position it out of the way.
5. Remove the screws which retain blower to blower deck.
6. Remove the blower assembly with the control wiring still attached.

7. Vacuum the motor and the blower using a soft brush attachment. Care must be used not to disturb any balance weights (clips) on the blower wheel vanes.
8. Before reinstalling the blower assembly, inspect the heat exchanger which is visible in the blower opening of the blower deck. If it requires cleaning, vacuum it with a soft brush attachment.
9. Reinstall the blower assembly. Replace mounting screws that hold the blower assembly to the front portion of the blower deck. Two mounting screws used on the sides of the blower are used for shipping purposes only, and are not necessary after the furnace has been installed.
10. Reinstall the control box and reconnect the wiring harness plugs.
11. Replace the access doors and restore the electrical supply to the unit.

Burner Removal/Cleaning

The main burners should be checked periodically for dirt accumulation.

If cleaning is required, follow this procedure:

1. Turn off the electrical power to the unit.
2. Remove the access door.
3. Remove the igniter.
4. Turn off the gas supply at the external manual shutoff valve and loosen the ground union joint.
5. Remove the airshield.
6. Remove the four screws that hold the burner assembly to the vest panel and remove the assembly.
7. Remove burners from the burner assembly.
8. Burners may be cleaned by rinsing in hot water.
9. Reassemble the burners in the reverse order, making sure the burner shield is tightened securely in place.

Cleaning the Heat Exchanger

1. Turn off the main manual gas valve external to the furnace.
2. Turn off electrical power to the furnace.
3. Remove the upper access door and remove airshield
4. Disconnect wires from HSI sensor, rollout switch and HSI igniter. Remove igniter **carefully**, as it is easily broken.
5. Remove the screws that hold the burner assembly to the vestibule panel and remove the assembly. The lower portion of the heat exchanger will now be exposed.
6. Remove inducer blower and motor at the top of the furnace. Remove upper plate.
7. The upper portion of the heat exchanger is now exposed.
8. With a long flexible wire brush, clean inside each tube at both the top and bottom. The brush must pass around the rear heat exchanger tubes. Vacuum loose scale and dirt from each tube.
9. Clean - vacuum all burners.
10. Replace all components in reverse order. Reconnect all wiring.
11. Restore electrical power and gas supply to the furnace.
12. Check furnace operation.

TROUBLESHOOTING

The following visual checks should be made before troubleshooting:

1. Check to see that the power to the furnace and the ignition control module is ON.
2. The manual shutoff valves in the gas line to the furnace must be open.
3. Make sure all wiring connections are secure.
4. Review the sequence of operation.

Start the system by setting the thermostat above room temperature. Observe the system's response. Then use the Troubleshooting tables in this manual to check the system's operation.

Use the troubleshooting table by reading the upper left-hand box and then following the instructions in each box. If the condition described in the box is true (yes answer), go down to the next box. If the condition is not true (no answer), go to the box to the right.

Continue checking and answering the questions in the boxes until the problem is explained and corrective action is described. After any maintenance or repair, the troubleshooting sequence can be repeated until normal system operation is obtained.

FURNACE CONTROL DIAGNOSTICS

The furnace has built-in, self diagnostic capability. If a system problem occurs, a fault code is shown by a blinking LED on the blower deck. It is located just to the right of the wiring harness plug. To view the LED, remove the top furnace panel. DO NOT remove the furnace blower compartment panel OR turn off furnace power as either action will clear the control's memory of the fault.

The control continuously monitors its own operation and the operation of the system. If a failure occurs, the LED will indicate the failure code. If the failure is internal to the control, the light will stay on continuously. In this case, the entire control should be replaced as the control is not field repairable.

If the sensed failure is in the system (external to the control), the LED will flash in the following flash-pause sequences to indicate failure status (each flash will last approximately 1/4 second, each pause will last approximately 2 seconds).

- 1 flash, then pause..... *System lockout*
- 2 flashes, then pause *Pressure switch stuck closed*
- 3 flashes, then pause *Pressure switch stuck open*
- 4 flashes, then pause *Open high limit switch*
- 5 flashes, then pause *Open rollout switch*
- Continuous flashing
(no pause)..... *Flame has been sensed when
no flame should be present
(no call for heat)*
- LED on -not flashing..... *Faulty control*

The LED will also flash once at power-up. If the control is locked out, it may be reset by momentary power interruption. Either the 24v thermostat or line voltage may be interrupted for 30 seconds or longer.

WARNING: Never jump pressure switch to allow furnace operation. To do so will allow furnace to operate under potentially hazardous conditions.

WARNING: Do not try to repair controls. Replace defective controls with UPG Source 1 Parts.

WARNING: Never adjust pressure switch to allow furnace operation.

FAN ONLY CHECK

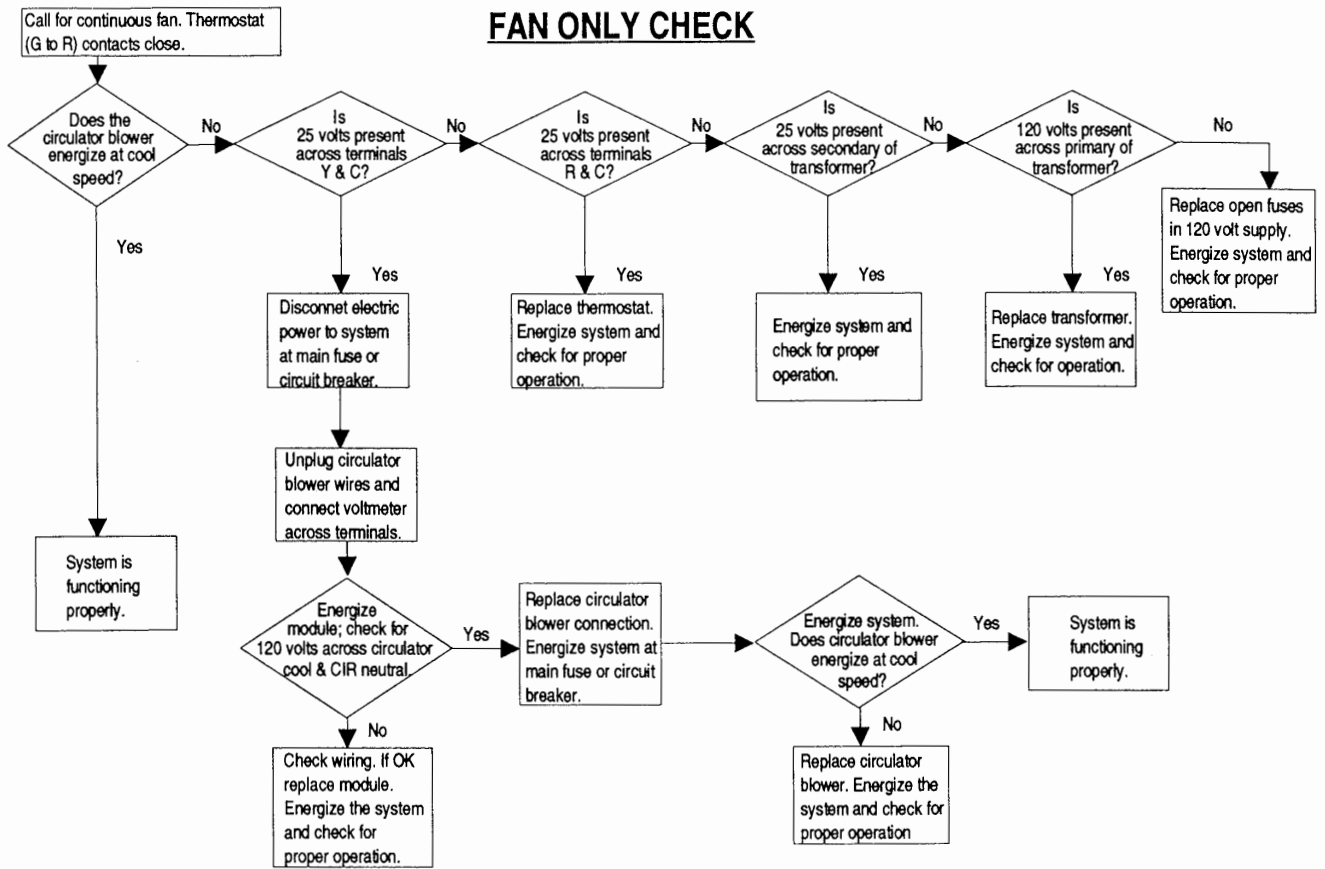

COOLING CYCLE CHECK

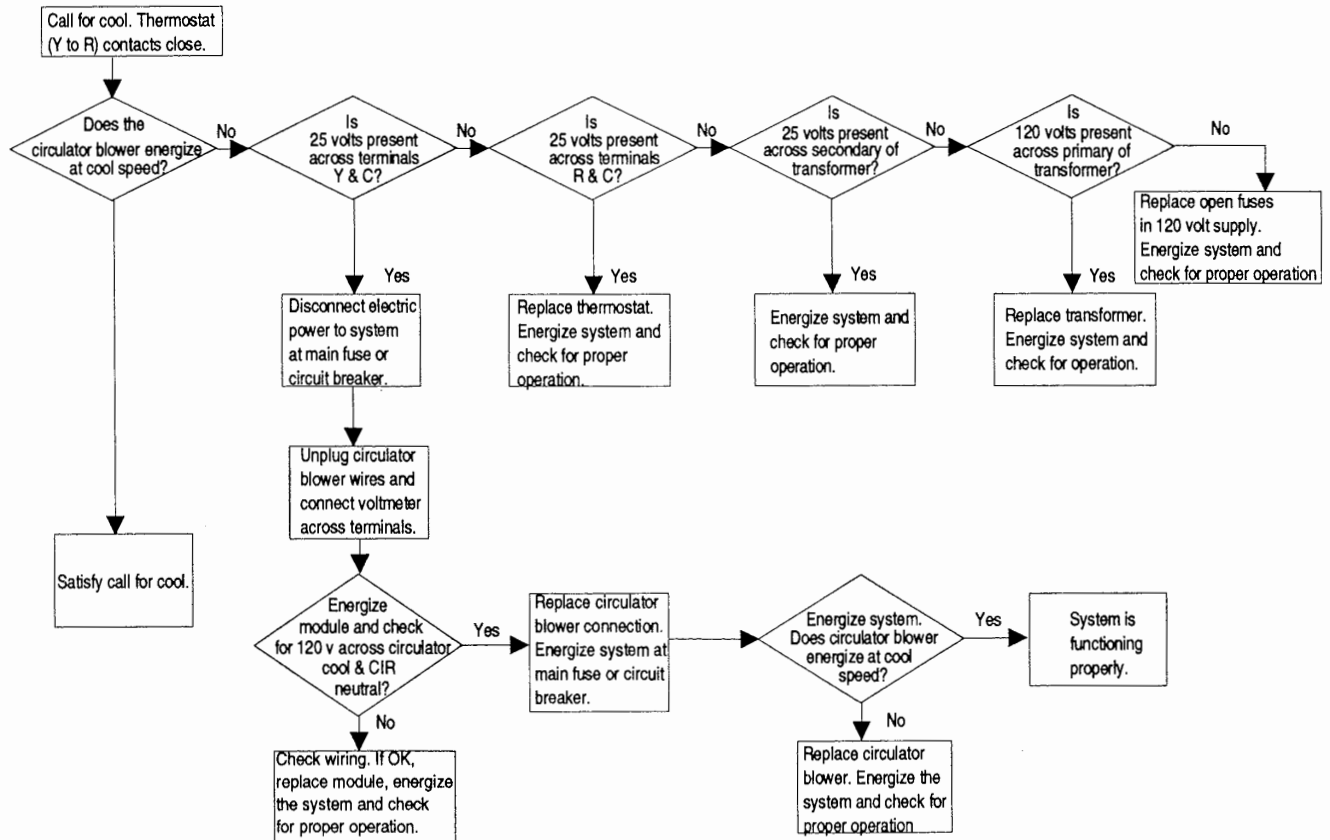

PREPURGE/IGNITOR WARM-UP

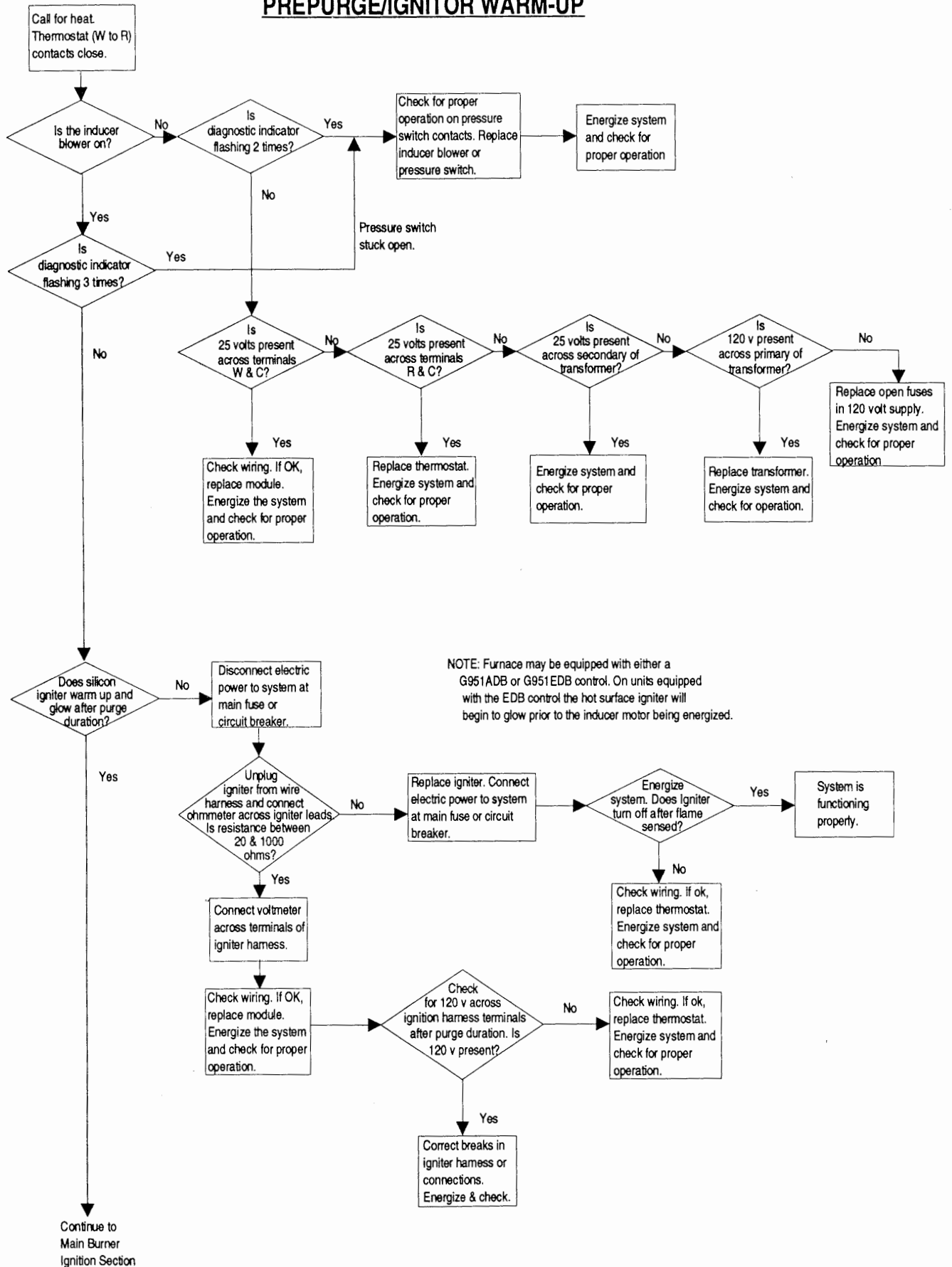

NOTE: Furnace may be equipped with either a G951ADB or G951EDB control. On units equipped with the EDB control the hot surface igniter will begin to glow prior to the inducer motor being energized.

MAIN BURNER IGNITION

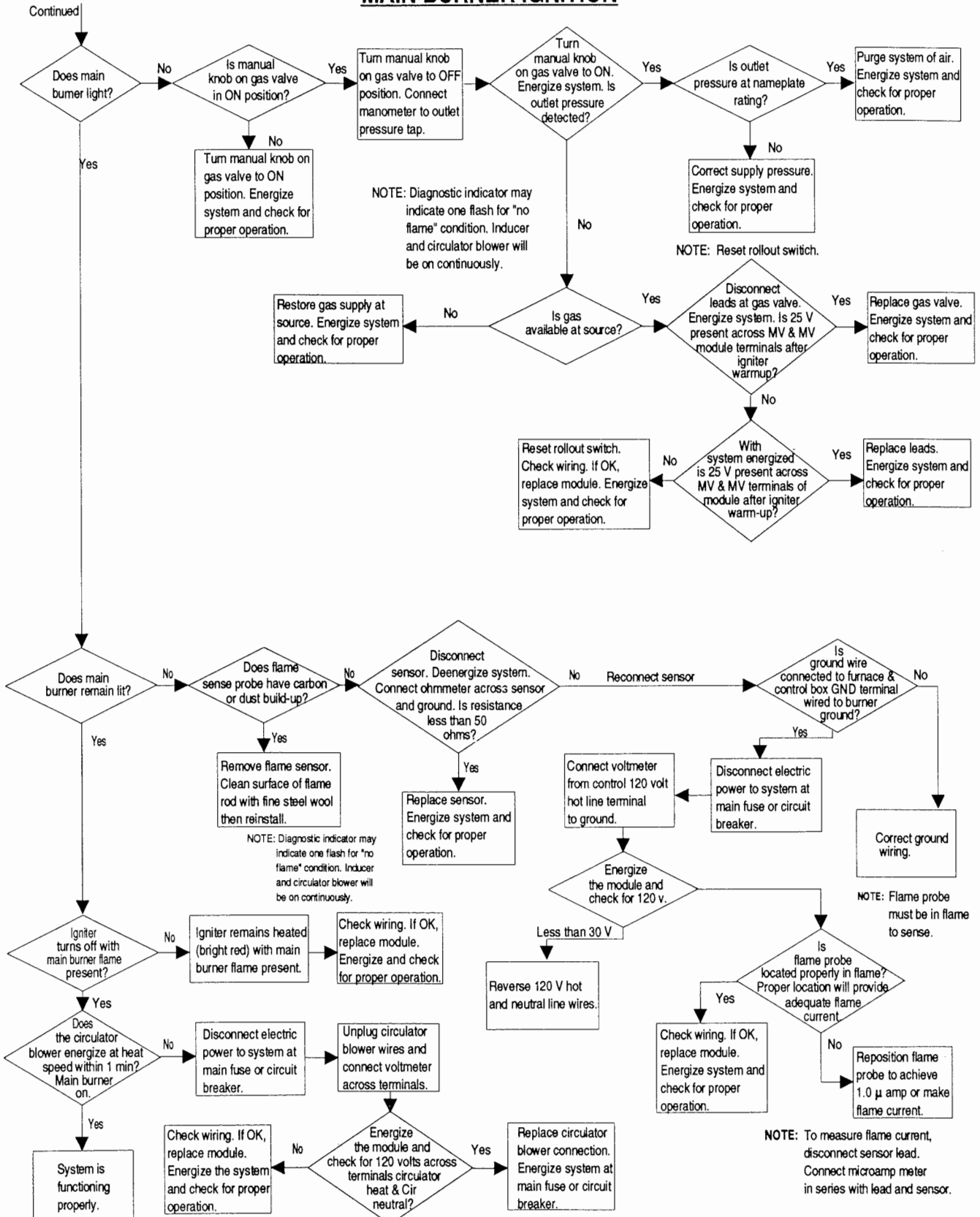

WIRING DIAGRAM - UPFLOW MULTI-SPEED MODELS

NOTE: The furnace's control system depends on correct polarity of the power supply.

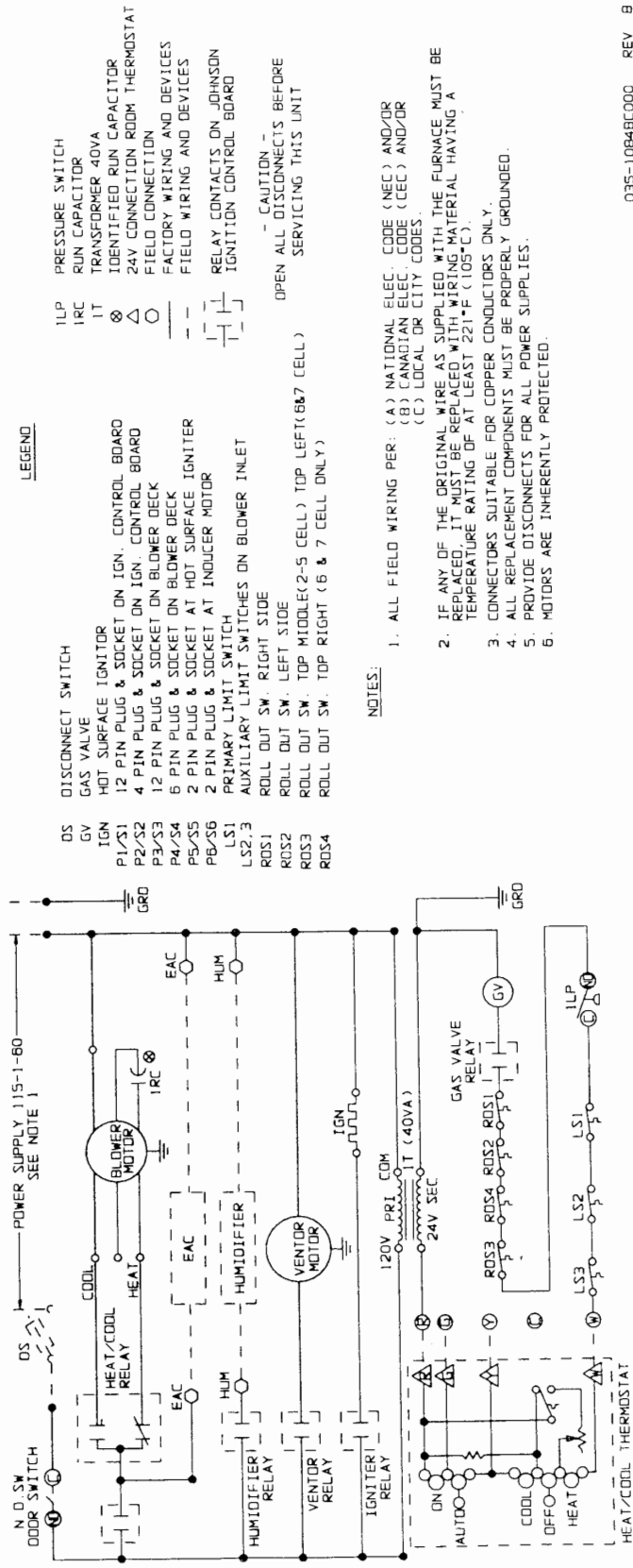
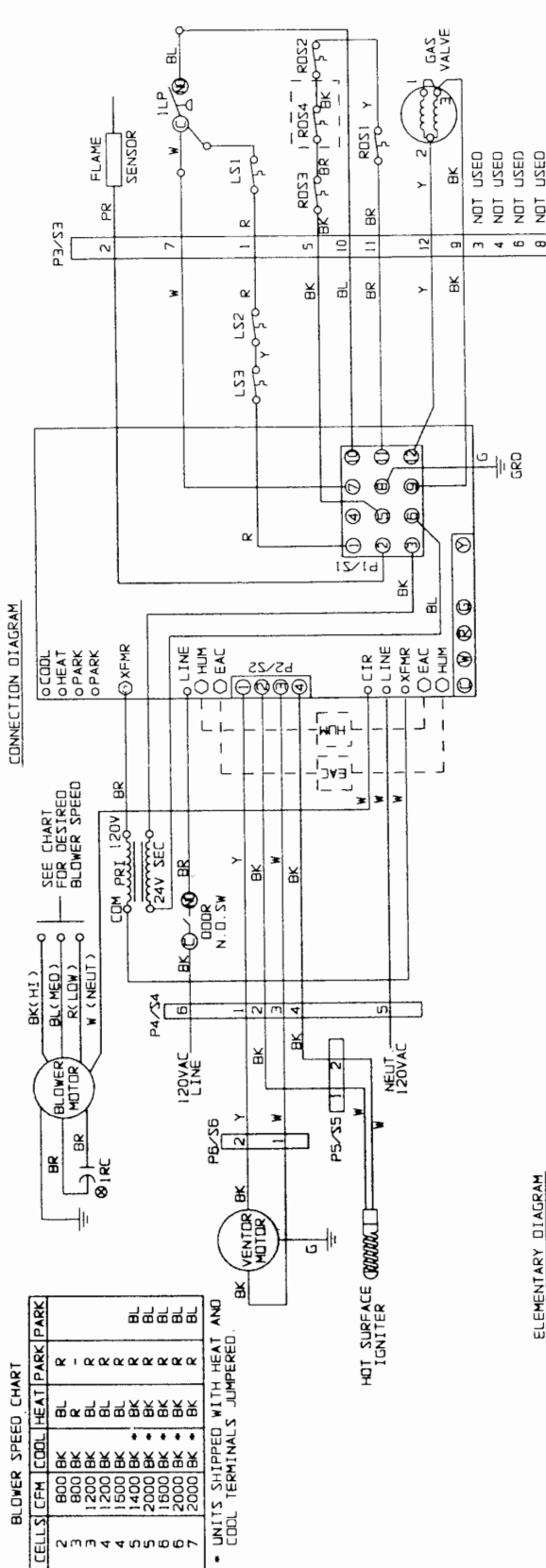

WIRING DIAGRAM - DOWNFLOW MODELS

NOTE: The furnace's control system depends on correct polarity of the power supply.

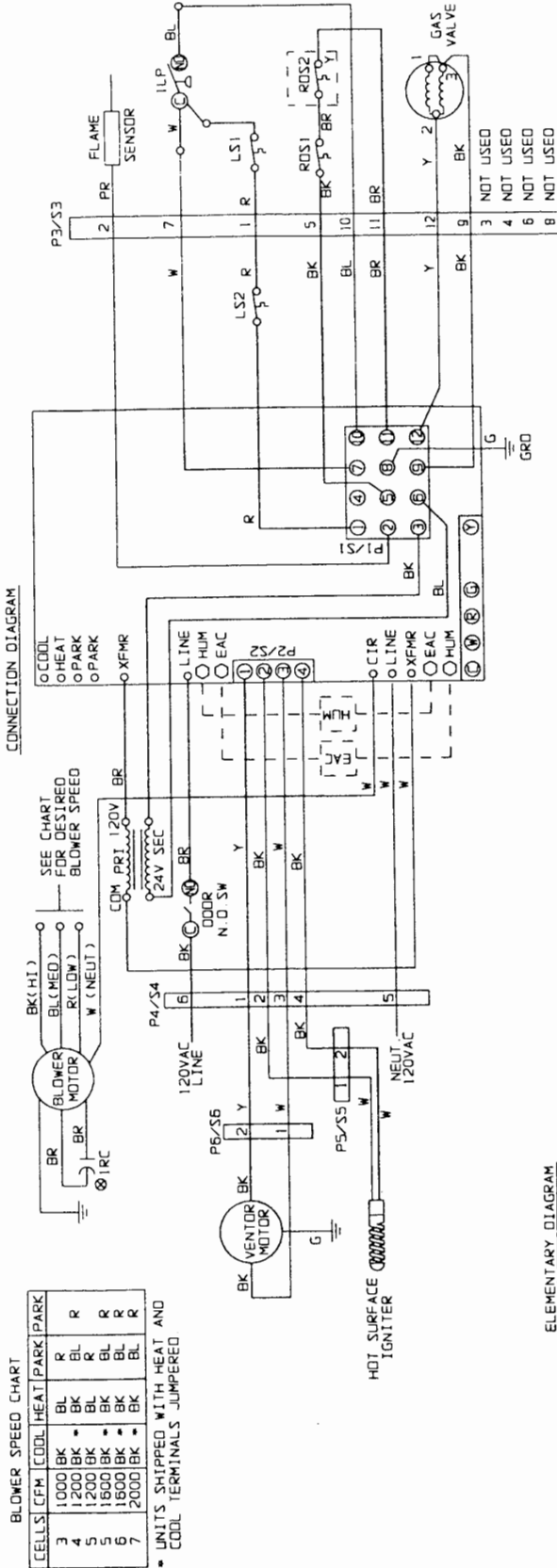

BLOWER SPEED CHART

CELLS	CFM	COOL	HEAT	PARK	PARK
3	1000	BK	BL	R	R
4	1200	BK	BL	R	R
5	1200	BK	BL	R	R
5	1600	BK	BL	R	R
6	1600	BK	BL	R	R
7	2000	BK	BL	R	R

* UNITS SHIPPED WITH HEAT AND COOL TERMINALS JUMPED

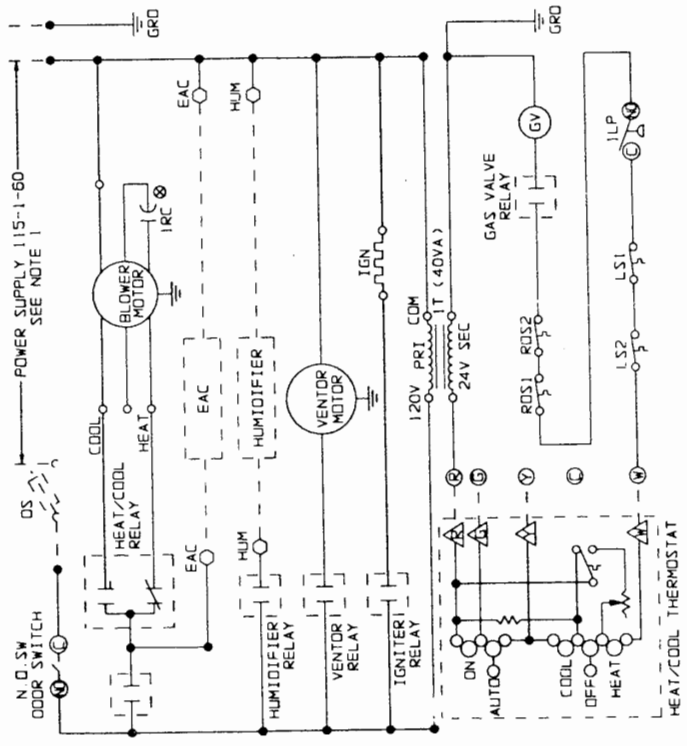

- NOTES:**
- ALL FIELD WIRING PER: (A) NATIONAL ELEC. CODE (NEC) AND/OR (B) CANADIAN ELEC. CODE (CEC) AND/OR (C) LOCAL OR CITY CODES
 - IF ANY OF THE ORIGINAL WIRE AS SUPPLIED WITH THE FURNACE MUST BE REPLACED IT MUST BE REPLACED WITH WIRING MATERIAL HAVING A TEMPERATURE RATING OF AT LEAST (221)*F (105°C) RISE.
 - CONNECTORS SUITABLE FOR COPPER CONDUCTORS ONLY.
 - ALL REPLACEMENT COMPONENTS MUST BE PROPERLY GROUNDED.
 - PROVIDE DISCONNECTS FOR ALL POWER SUPPLIES.
 - MOTORS ARE INHERENTLY PROTECTED.
- LEGEND:**
- ILP PRESSURE SWITCH
 - IRC RUN CAPACITOR
 - IT TRANSFORMER 40VA
 - ⊗ IDENTIFIED RUN CAPACITOR
 - △ 24V CONNECTION ROOM THERMOSTAT
 - FIELD CONNECTION
 - FACTORY WIRING AND DEVICES
 - FIELD WIRING AND DEVICES
 - ⎓ RELAY CONTACTS ON JOHNSON IGNITION CONTROL BOARD
 - CAUTION - OPEN ALL DISCONNECTS BEFORE SERVICING THIS UNIT

BLOWER PERFORMANCE - UPFLOW/HORIZONTAL - CFM (Includes Filter)

MODEL	SPEED TAP	EXTERNAL STATIC PRESSURE, INCHES W.C.									
		0.10	0.20	0.30	0.40	0.50	0.60	0.70	0.80	0.90	1.00
PBKM-LD08*040 (See Note 1)	HIGH	1150	1090	1021	945	877	791	670	458	—	—
	MED	1027	971	930	862	790	714	597	411	—	—
	LOW	846	817	782	726	673	608	500	317	—	—
PBKM-LD08*060 (See Note 3)	HIGH	998	965	934	878	827	769	665	576	489	323
	MED	890	858	824	775	741	660	584	504	—	—
	LOW	—	—	—	—	—	—	—	—	—	—
PBKM-LD12*060 (See Note 2)	HIGH	1548	1480	1396	1312	1270	1126	1029	908	736	563
	MED	1275	1221	1180	1152	1080	1016	922	807	657	482
	LOW	—	1055	1050	1034	998	960	888	773	645	446
PBKM-LD12*080 (See Note 2)	HIGH	1605	1538	1427	1331	1284	1178	1080	978	815	619
	MED	1172	1195	1140	1102	1076	985	908	822	682	5663
	LOW	—	—	967	932	925	885	851	763	630	—
PBKM-LD16*080 (See Note 3)	HIGH	1967	1884	1795	1697	1605	1477	1340	1167	986	799
	MED	1822	1758	1673	1592	1512	1399	1256	1107	917	742
	LOW	—	—	1440	1383	1330	1240	1142	986	841	702
PBKM-LD14*100 (See Note 3)	HIGH	1861	1798	1698	1584	1494	1364	1258	1087	898	756
	MED	1569	1503	1438	1375	1277	1182	1071	928	772	643
	LOW	—	1295	1270	1198	1156	1063	966	857	725	616
PBKM-LD20*100 (See Notes 4, 7)	HIGH	2380	2318	2243	2195	2107	2017	1944	1811	1703	1583
	MED	1989	1976	1967	1949	1907	1832	1755	1680	1566	1477
	LOW	—	—	1585	1570	1527	1502	1447	1398	1333	1248
PBKM-LD16*120 (See Note 4)	HIGH	2117	2023	1920	1821	1731	1587	1459	1302	1045	818
	MED	1905	1821	1743	1649	1563	1465	1332	1168	957	643
	LOW	1546	1532	1495	1424	1357	1268	1155	1000	840	663
PBKM-LD20*120 (See Notes 5, 7)	HIGH	—	2367	2342	2270	2198	2110	2004	1913	1797	1581
	MED	2027	1986	1945	1917	1877	1820	1763	1653	1558	1445
	LOW	—	—	—	1349	1327	1312	1281	1233	1150	1078
PBKM-LD20*140 (See Notes 6, 7)	HIGH	2204	2154	2081	2055	2002	1933	1843	1706	1545	1409
	MED	—	1805	1779	1758	1715	1656	1579	1507	1395	1292
	LOW	—	—	—	1451	1451	1423	1377	1284	1201	1095
PBKM-LV12N080	1200** CFM SETTING	1200	1200	1200	1200	1200	1200	1200	1200	—	—
PBKM-LV14N100	1400** CFM SETTING	1400	1400	1400	1400	1400	1400	1400	1400	1400	1400
PBKM-LV20N100 (See Note 7)	2000** CFM SETTING	2000	2000	2000	2000	2000	2000	2000	2000	2000	—

These conditions are outside the recommended heating operating range.

Airflow is expressed in standard cubic feet per minute.

Motor voltage at 115V

** Other CFM settings are available.

Figures shown are for left side return air installation, except for the D20 unit which must use both sides for applications over 1600 CFM. For all bottom applications, see correction factors listed in Notes 1-6.

NOTES:

- 1 - CFM shown x .90
- 2 - CFM shown x .98
- 3 - CFM shown x .97
- 4 - CFM shown x .93
- 5 - CFM shown x .91
- 6 - CFM shown x .96
- 7 - Air flow shown is with return air from both sides. Use the derate factors for bottom return

BLOWER PERFORMANCE - DOWNFLOW - CFM (Includes Filter)

MODEL	SPEED TAP	EXTERNAL STATIC PRESSURE, INCHES W.C.									
		0.10	0.20	0.30	0.40	0.50	0.60	0.70	0.80	0.90	1.00
PBKM-LD10*060	HIGH	1356	1315	1222	1154	1090	988	888	771	630	462
	MED	1144	1080	1023	958	919	830	740	635	510	425
	LOW	967	942	908	864	811	747	672	574	476	344
PBKM-LD12*080	HIGH	1557	1502	1410	1344	1240	1142	1025	882	740	567
	MED	1289	1238	1175	1098	1030	938	855	712	582	455
	LOW	1136	1081	1039	965	906	831	739	617	515	413
PBKM-LD12*100	HIGH	1599	1535	1465	1375	1277	1182	1089	948	723	554
	MED	1390	1327	1266	1195	1109	1027	919	813	597	458
	LOW	1175	1136	1093	1027	967	900	816	764	497	382
PBKM-LD16*100	HIGH	2043	2000	1893	1823	1726	1627	1503	1382	1249	1134
	MED	1706	1655	1593	1533	1450	1366	1265	1163	1062	950
	LOW	1452	1406	1373	1317	1245	1174	1112	1025	935	817
PBKM-LD16*115	HIGH	2053	1977	1899	1817	1725	1623	1519	1401	1265	1120
	MED	1711	1667	1606	1530	1458	1383	1284	1184	1066	951
	LOW	1460	1434	1407	1363	1310	1232	1137	1064	964	854
PBKM-LD20*130	HIGH	2330	2248	2177	2103	2024	1910	1789	1698	1555	1419
	MED	1867	1858	1814	1740	1675	1593	1524	1443	1330	1204
	LOW	1613	1531	1516	1490	1495	1411	1337	1250	1225	1010

 Operation at these heating conditions exceed the listed temperature rise range. A higher blower speed must be selected.

- * Model designator may be "N" for standard units, or "L" for factory built low NOx units.
 Airflow is expressed in standard cubic feet per minute.
 Motor voltage at 115V

FRASER-JOHNSTON

GAS-FIRED FURNACES HIGH EFFICIENCY MULTI-POSITION (UPFLOW/HORIZONTAL) INDUCED COMBUSTION 40-140 MBH INPUT

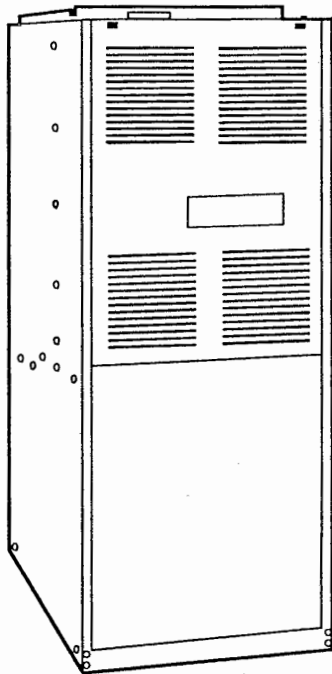

MODELS PBKM



DESCRIPTION

These high efficiency, compact units employ induced combustion, reliable hot surface ignition and high heat transfer tubular heat exchangers. The units are factory shipped for installation in upflow or horizontal applications.

These furnaces are designed for residential installation in a basement, closet, alcove attic, recreation room or garage and are ideal for commercial applications. All units are factory assembled, wired and tested to assure safe dependable and economical installation and operation.

These units are Category I listed and may be common vented with another gas appliance as allowed by the National Fuel Gas Code.

FEATURES

- Easily applied in upflow, horizontal left, horizontal right installations with no conversion necessary
- Electronic hot surface ignition with high reliability and dependability
- 100% shut off main gas valve for added safety
- Rollout safety control
- Low unit amp requirement for easy application
- High quality inducer motor for quiet operation
- Built-in self diagnostics with fault code display
- Integrated control module for simplicity and reliable, economical operation
- Standard terminals for controlling humidifiers and EAC's
- 40 VA control transformer
- Easy to connect power and control wiring
- Efficiency ratings of 80 AFUE attained by using tubular heat exchangers
- Cooling relay supplied for easy installation of add-on cooling
- Multi-speed PSC, direct-drive blower motors ("D" models) to match cooling requirements
- 3 variable speed blower models which provide constant CFM at varying static pressure
- Adjustable fan-off settings to eliminate "cold-blow"
- Compact 40-in height allows installation in small space confines
- 20 year warranty (10 year commercial applications) offered on heat exchanger and 5 years for parts
- All models are propane convertible
- Attractive baked enamel finish for durability

DIMENSIONS

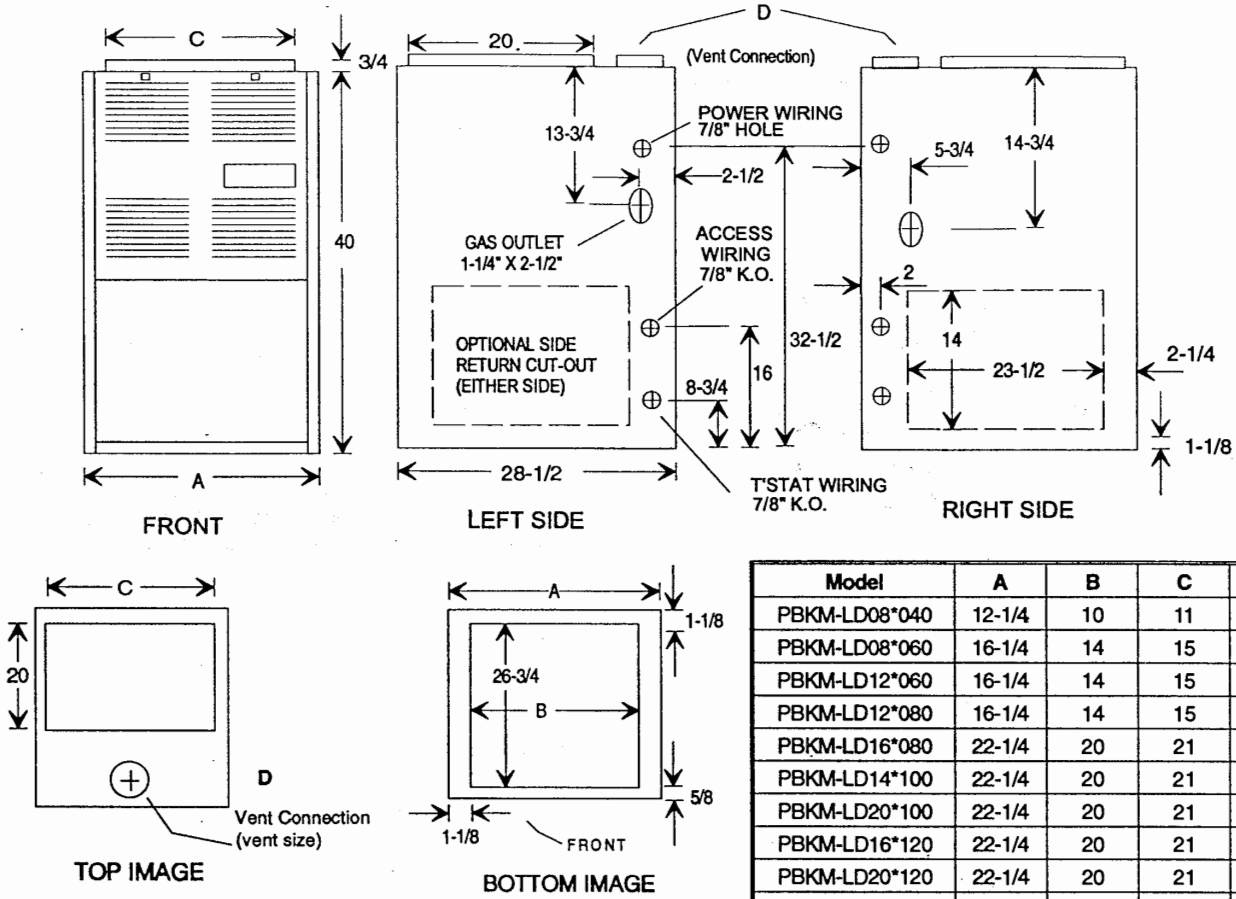

All dimensions are in inches and are approximate.

Model	A	B	C	D
PBKM-LD08*040	12-1/4	10	11	3
PBKM-LD08*060	16-1/4	14	15	3
PBKM-LD12*060	16-1/4	14	15	3
PBKM-LD12*080	16-1/4	14	15	4
PBKM-LD16*080	22-1/4	20	21	4
PBKM-LD14*100	22-1/4	20	21	4
PBKM-LD20*100	22-1/4	20	21	4
PBKM-LD16*120	22-1/4	20	21	4
PBKM-LD20*120	22-1/4	20	21	4
PBKM-LD20*140	26-1/4	24	25	4
PBKM-LV12N080	22-1/4	14	15	4
PBKM-LV14N100	22-1/4	20	21	4
PBKM-LV20N100	22-1/4	20	21	4

RATINGS & PHYSICAL/ELECTRICAL DATA

MODEL NUMBER	HEAT. CAP. INPUT MBH	SS OUTPUT MBH	AFUE ¹ I.C.S.	AIR TEMP RISE °F	CFM @ .5 ESP	MAX. OUTLET AIR TEMP °F	BLOWER			MAX. OVER CURRENT PROTECT.	TOTAL UNIT AMPS	MIN. WIRE (AWG) @ 75'
							DIA.	WIDTH	HP			
PBKM-LD08*040	40	32	80	10-40	877	180	9	6	1/4	15	12	14
PBKM-LD08*060	60	48	80	35-65	827	180	10	7	1/6	15	12	14
PBKM-LD12*060	60	48	80	25-55	1270	180	10	7	1/2	15	12	14
PBKM-LD12*080	80	64	80	25-55	1284	180	10	7	1/2	15	12	14
PBKM-LD16*080	80	64	80	20-50	1605	180	10	10	1/2	15	12	14
PBKM-LD14*100	100	80	80	30-60	1494	180	10	9	1/2	15	12	14
PBKM-LD20*100	100	80	80	30-60	2107	180	11	10	3/4	15	13.8	14
PBKM-LD16*120	120	96	80	30-60	1731	180	10	9	3/4	15	13.0	14
PBKM-LD20*120	120	96	80	25-55	2198	180	11	10	3/4	15	13.8	14
PBKM-LD20*140	140	112	80	35-65	2002	180	11	10	3/4	15	13.8	14
PBKM-LV12N080	80	64	80	25-55	1285	180	10	7	1/2	15	12	14
PBKM-LV14N100	100	80	80	30-60	1500	180	10	9	1/2	15	12	14
PBKM-LV20N100	100	80	80	30-60	2100	180	11	10	1	15	12	14

¹ AFUE numbers are determined in accordance with DOE test procedures for isolated combustion air.
 * Model number may be "N" for standard units, or "L" for factory built low NOx units.

- NOTES:
- For altitudes above 2,000 ft., reduce capacity 4% for each 1,000 ft. above sea level.
 - Wire size based on copper conductors, 60°C, 3% voltage drop.
 - Continuous return air temperature must not be below 55°F.

FILTER SIZE/ADD-ON COOLING

MODEL NUMBER	FILTER SIZE		ADD-ON COOLING		APPROX. OPER. WEIGHT
	SIDE	BOTTOM	TONS	CFM @ .5 ESP ¹	
PBKM-LD08*040	16 x 25	12 x 27	1, 1-1/2, 2	877	85
PBKM-LD08*060	16 x 25	16 x 27	1, 1-1/2, 2	827	98
PBKM-LD12*060	16 x 25	16 x 27	2, 2-1/2, 3	1270	102
PBKM-LD12*080	16 x 25	16 x 27	2, 2-1/2, 3	1284	115
PBKM-LD16*080	16 x 25	20 x 27	3, 3-1/2, 4	1605	119
PBKM-LD14*100	16 x 25	20 x 27	2-1/2, 3, 3-1/2	1494	130
PBKM-LD20*100	16 x 25	20 x 27	4, 5	2107	135
PBKM-LD16*120	16 x 25	20 x 27	3, 3-1/2, 4	1731	146
PBKM-LD20*120	16 x 25	20 x 27	3-1/2, 4, 5	2198	151
PBKM-LD20*140	16 x 25	25 x 27	3-1/2, 4, 5	2002	163
PBKM-LV12N080	16 x 25	16 x 27	1, 1-1/2, 2, 2-1/2, 3	CFM As Selected	119
PBKM-LV14N100	16 x 25	20 x 27	2, 2-1/2, 3, 3-1/2		135
PBKM-LV20N100	16 x 25	20 x 27	3-1/2, 4, 5		140

¹ ESP (External Static Pressure) .5" W.C. is at furnace outlet ahead of cooling coil.

* Model number may be "N" for standard units, or "L" for factory built low NOx units.

NOTES: ● Filters may be provided as an accessory or field supplied. High velocity type must be used.
● Air flows above 1800 CFM require either return from two sides or bottom.

ACCESSORIES

Propane Conversion Kit – 1NP0347

This accessory conversion kit may be used to convert natural gas units for propane (LP) operation. Conversion must be made by qualified distributor or dealer personnel.

High Altitude Pressure Switch Kits –

These accessory kits must be used to convert units for high altitude operation. Conversion must be made by qualified distributor or dealer personnel.

KIT	APPLICATION	MODELS
1PS0302	2000 - 5500 FT.	40, 60 MBH
1PS0303		80, 100, 120 MBH
1PS0304		140 MBH
1PS0301	5500 - 10,000 FT.	40, 60 MBH
1PS0302		80, 100, 120 MBH
1PS0303		140 MBH

NOTE: For high altitude conversion, an orifice change may also be required. Refer to form 650.69-N2.11V for application information.

Internal Side Filter (With Retainer) - 1BF0302 (Upflow)

This provides a cleanable, high velocity type filter and retainer hardware for mounting inside the furnace cabinet.

External Side Return Filter Rack - 1SR0302 (Upflow)

Provides a 16 x 25 cleanable, high velocity type filter and attaches to the furnace side panel and the return air duct. The filter is easily replaced. Package contains six filter racks with filters.

Internal Mount Bottom Return Filter - (Upflow)

This provides a cleanable, high velocity type filter and retainer hardware for mounting inside the furnace cabinet. This type filter requires removing the furnace blower compartment cover to change the filter.

1BF0301 = For 12" cabinet models

1BF0302 = For 16" cabinet models

1BF0303 = For 22" cabinet models

1BF0304 = For 26" cabinet models

Low NOx Kit - 1LN0302 - Converts unit to low NOx requirements.

External Bottom Return Upflow Or Horizontal End Return Filter Rack

Provides a cleanable, high velocity type filter and rack. Attaches to the end of the furnace and provides duct flanges.

1HF0301 = For 12" cabinet models

1HF0302 = For 16" cabinet models

1HF0303 = For 22" cabinet models

1HF0304 = For 26" cabinet models

FIELD WIRING DIAGRAM ("D" models only)

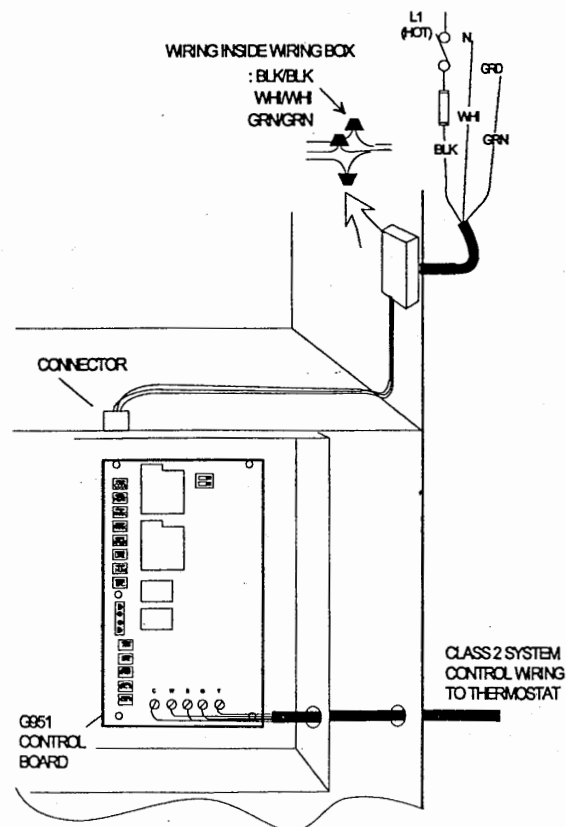

BLOWER PERFORMANCE

MODEL	SPEED TAP	EXTERNAL STATIC PRESSURE, INCHES W.C.									
		0.10	0.20	0.30	0.40	0.50	0.60	0.70	0.80	0.90	1.00
PBKM-LD08*040 (See Note 1)	HIGH	1150	1090	1021	945	877	791	670	458	—	—
	MED	1027	971	930	862	790	714	597	411	—	—
	LOW	846	817	782	726	673	608	500	317	—	—
PBKM-LD08*060 (See Note 3)	HIGH	998	965	934	878	827	769	665	576	489	323
	MED	890	858	824	775	741	660	584	504	—	—
	LOW	—	—	—	—	—	—	—	—	—	—
PBKM-LD12*060 (See Note 2)	HIGH	1548	1480	1396	1312	1270	1126	1029	908	736	563
	MED	1275	1221	1180	1152	1080	1016	922	807	657	482
	LOW	—	1055	1050	1034	998	960	888	773	645	446
PBKM-LD12*080 (See Note 2)	HIGH	1605	1538	1427	1331	1284	1178	1080	978	815	619
	MED	1172	1195	1140	1102	1076	985	908	822	682	5663
	LOW	—	—	967	932	925	885	851	763	630	—
PBKM-LD16*080 (See Note 3)	HIGH	1967	1884	1795	1697	1605	1477	1340	1167	986	799
	MED	1822	1758	1673	1592	1512	1399	1256	1107	917	742
	LOW	—	—	1440	1383	1330	1240	1142	986	841	702
PBKM-LD14*100 (See Note 3)	HIGH	1861	1798	1698	1584	1494	1364	1258	1087	898	756
	MED	1569	1503	1438	1375	1277	1182	1071	928	772	643
	LOW	—	1295	1270	1198	1156	1063	966	857	725	616
PBKM-LD20*100 (See Notes 4, 7)	HIGH	2380	2318	2243	2195	2107	2017	1944	1811	1703	1583
	MED	1989	1976	1967	1949	1907	1832	1755	1680	1566	1477
	LOW	—	—	1585	1570	1527	1502	1447	1398	1333	1248
PBKM-LD16*120 (See Note 4)	HIGH	2117	2023	1920	1821	1731	1587	1459	1302	1045	818
	MED	1905	1821	1743	1649	1563	1465	1332	1168	957	643
	LOW	1546	1532	1495	1424	1357	1268	1155	1000	840	663
PBKM-LD20*120 (See Notes 5, 7)	HIGH	—	2367	2342	2270	2198	2110	2004	1913	1797	1581
	MED	2027	1986	1945	1917	1877	1820	1763	1653	1558	1445
	LOW	—	—	—	1349	1327	1312	1281	1233	1150	1078
PBKM-LD20*140 (See Notes 6, 7)	HIGH	2204	2154	2081	2055	2002	1933	1843	1706	1545	1409
	MED	—	1805	1779	1758	1715	1656	1579	1507	1395	1292
	LOW	—	—	—	1451	1451	1423	1377	1284	1201	1095
PBKM-LV12N080	1200** CFM SETTING	1200	1200	1200	1200	1200	1200	1200	1200	—	—
PBKM-LV14N100	1400** CFM SETTING	1400	1400	1400	1400	1400	1400	1400	1400	1400	1400
PBKM-LV20N100 (See Note 7)	2000** CFM SETTING	2000	2000	2000	2000	2000	2000	2000	2000	2000	—

These conditions are outside the recommended heating operating range.

Airflow is expressed in standard cubic feet per minute.

Motor voltage at 115V

Figures shown are for left side return air installation, except for the D20 unit which must use both sides for applications over 1800 CFM. For all bottom applications, see correction factors listed in Notes 1-6.

* Model number may be "N" for standard units, or "L" for factory built low NOx units.

** These are constant CFM units and will provide selected CFM up to maximum static conditions. Other CFM settings are available.

NOTES:

- 1 - CFM shown x .90
- 2 - CFM shown x .98
- 3 - CFM shown x .97
- 4 - CFM shown x .93
- 5 - CFM shown x .91
- 6 - CFM shown x .96
- 7 - Air flow shown is with return air from both sides.
Use the derate factors above for bottom return

FRASER-JOHNSTON
Heating ■ Air Conditioning

SHU 3M 295 .22

Code: EBF

650.69-TG2F

Supersedes: 650.69-TG2F (694)
Subject to change without notice. Printed in U.S.A.
Copyright © by Unitary Products Group 1995. All rights reserved.

Post Office Box 1592
York, Pennsylvania 17405-1592

Fraser-Johnston®

GAS-FIRED FURNACES

INDUCED COMBUSTION HIGH-EFFICIENCY DOWNFLOW 60-130 MBH INPUT

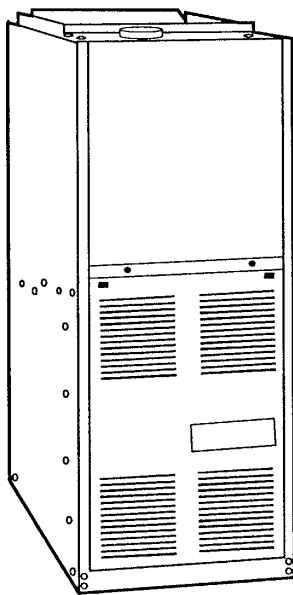

MODELS PBKD



DESCRIPTION

These high efficiency, dedicated downflow, compact units employ induced combustion, reliable hot surface ignition and high heat transfer tubular heat exchangers.

These furnaces are designed for residential installation in a closet, alcove, attic or garage and are ideal for commercial applications. All units are factory assembled, wired and tested to assure safe dependable and economical installation and operation. These units are Category I listed and may be common vented with another gas appliance as allowed by the National Fuel Gas Code.

FEATURES

- Dedicated downflow models may be easily applied without any field conversion
- Top vent connection allows installation in narrow locations
- Electronic hot surface ignition with high reliability and dependability
- 100% shut off main gas valve for added safety
- Rollout safety control
- Low unit amp requirement for easy replacement application
- Integrated control module for simplicity and reliable economical operation
- Built-in self diagnostics with fault code display
- Factory built low NOx models available
- High quality inducer motor for quiet operation
- Standard terminals for controlling humidifiers & EAC's
- 40 VA control transformer
- Easy to connect power and control wiring
- Efficiency ratings of 80 AFUE attained by using tubular heat exchangers
- Cooling relay standard for easy installation of add-on cooling
- Blower off-delay for cooling SEER improvement
- Multi-speed PSC, direct-drive blower motors to match cooling requirements
- Adjustable fan-off settings to eliminate "cold-blow"
- Compact 40-in height allows installation in small space confines
- 20-year limited warranty on heat exchanger
- 10-year limited warranty on heat exchanger when used on commercial applications
- 5-year limited warranty on all other parts
- All models are propane convertible
- Attractive baked enamel finish for durability

DIMENSIONS

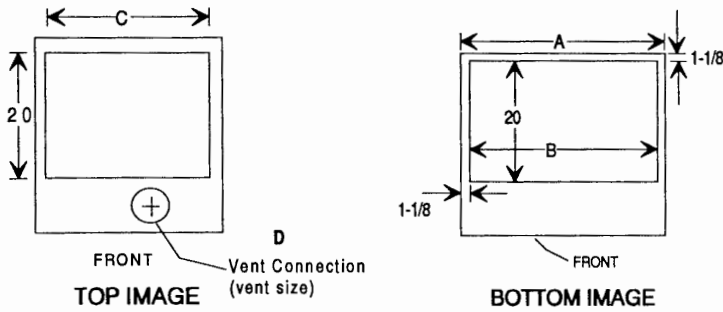
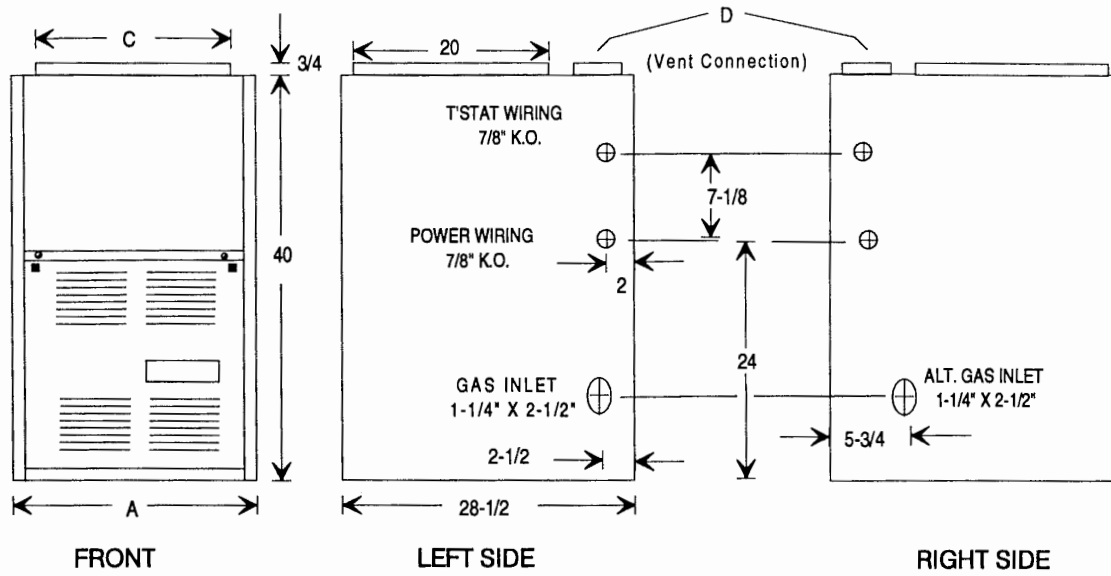

Model	A	B	C	D
PBKD-LD10 * 060	16-1/4	14	15	3
PBKD-LD12 * 080	16-1/4	14	15	4
PBKD-LD12 * 100	22-1/4	20	21	4
PBKD-LD16 * 100	22-1/4	20	21	4
PBKD-LD16 * 115	22-1/4	20	21	4
PBKD-LD20 * 130	26-1/4	24	25	4

All dimensions are in inches and are approximate. Certified dimensions are available upon request.

* Model designator may be "N" for standard units, or "L" for factory built low NOx units.

RATINGS & PHYSICAL/ELECTRICAL DATA

MODEL NUMBER	HEAT. CAP. INPUT MBH	SS OUTPUT MBH	AFUE ¹ I.C.S.	AIR TEMP RISE °F	CFM @ .5 ESP	MAX. OUTLET AIR TEMP °F	BLOWER			MAX. OVER-CURRENT PROTECT.	TOTAL UNIT AMPS	MIN. WIRE (AWG) @ 75'
							DIA.	WIDTH	HP			
PBKD-LD10 * 060	60	48	80	30-60	1090	160	10	7	1/4	15	12.0	14
PBKD-LD12 * 080	80	64	80	30-60	1240	160	10	8	1/2	15	12.0	14
PBKD-LD12 * 100	100	80	80	40-70	1277	170	10	10	1/2	15	12.0	14
PBKD-LD16 * 100	100	80	80	30-60	1726	160	11	10	3/4	15	12.0	14
PBKD-LD16 * 115	115	92	80	35-65	1725	165	11	10	3/4	15	13.8	14
PBKD-LD20 * 130	130	104	80	35-65	2024	165	11	10	3/4	15	13.8	14

* Model designator may be "N" for standard units, or "L" for factory built low NOx units.

¹ AFUE numbers are determined in accordance with DOE test procedures for isolated combustion air.

- NOTES:
- For altitudes above 2,000 ft., reduce capacity 4% for each 1,000 ft. above sea level.
 - Wire size based on copper conductors, 60°C, 3% voltage drop.
 - Continuous return air temperature **must not** be below 55°F.

FILTER SIZE/ADD-ON COOLING

MODEL NUMBER	FILTER SIZE	ADD-ON COOLING	CFM @ .5 ESP ¹	APPROX. OPER. WEIGHT
		TONS		
PBKD-LD10 * 060	(2) 14 x 20	1-1/2, 2, 2-1/2	1090	105
PBKD-LD12 * 080	(2) 14 x 20	2, 2-1/2, 3	1240	118
PBKD-LD12 * 100	(2) 14 x 20	2, 2-1/2, 3	1277	134
PBKD-LD16 * 100	(2) 14 x 20	3, 3-1/2, 4	1726	140
PBKD-LD16 * 115	(2) 14 x 20	3, 3-1/2, 4	1725	156
PBKD-LD20 * 130	(2) 14 x 20	3-1/2, 4, 5	2024	168

* Model designator may be "N" for standard units, or "L" for factory built low NOx units.

¹ ESP (External Static Pressure) .5" W.C. is at furnace outlet ahead of cooling coil.

NOTES: • High velocity, cleanable filters are provided.

ACCESSORIES

PROPANE CONVERSION KIT – 1NP0347 (48, 64 & 80 MBH) 1NP0348 (92, & 104 MBH)

This accessory conversion kit may be used to convert natural gas units for propane (LP) operation at altitudes up to 2,000 ft. Conversion should be made by qualified distributor or dealer personnel.

COMBUSTIBLE FLOOR BASE

1FB0302 = For 16" cabinet models

1FB0303 = For 22" cabinet models

1FB0304 = For 26" cabinet models

LOW NOx KIT

Converts standard units to meet low NOx requirements.

FIELD WIRING DIAGRAM

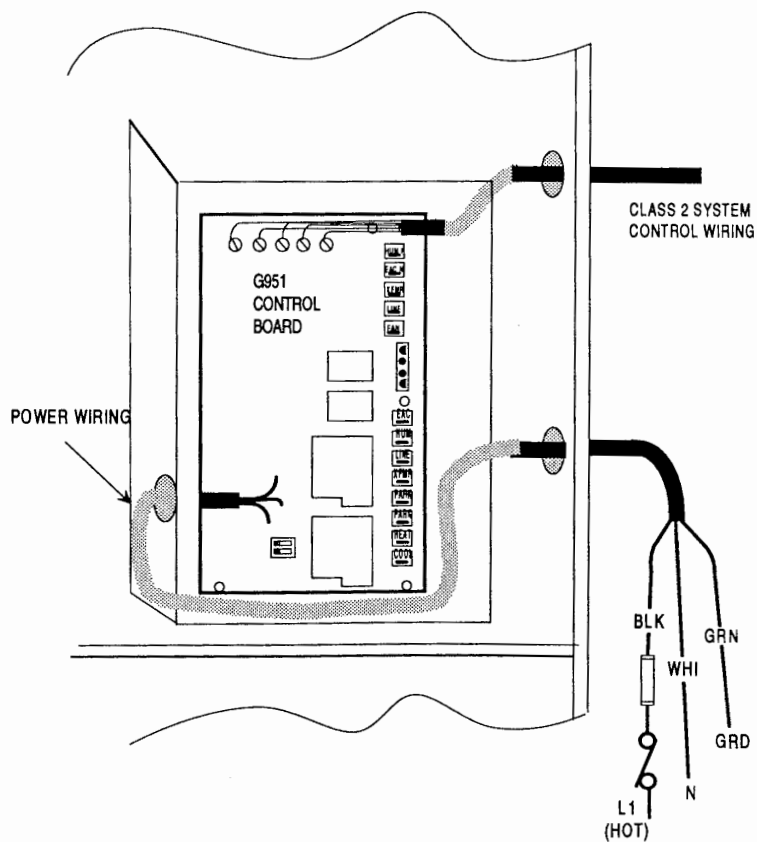

BLOWER PERFORMANCE

MODEL	SPEED TAP	EXTERNAL STATIC PRESSURE, INCHES W.C.									
		0.10	0.20	0.30	0.40	0.50	0.60	0.70	0.80	0.90	1.00
PBKD-LD10 * 060	HIGH	1356	1315	1222	1154	1090	988	888	771	630	462
	MED	1144	1080	1023	958	919	830	740	635	510	425
	LOW	967	942	908	864	811	747	672	574	476	344
PBKD-LD12 * 080	HIGH	1557	1502	1410	1344	1240	1142	1025	882	740	567
	MED	1289	1238	1175	1098	1030	938	855	712	582	455
	LOW	1136	1081	1039	965	906	831	739	617	515	413
PBKD-LD12 * 100	HIGH	1599	1535	1465	1375	1277	1182	1089	948	723	554
	MED	1390	1327	1266	1195	1109	1027	919	813	597	458
	LOW	1175	1136	1093	1027	967	900	816	764	497	382
PBKD-LD16 * 100	HIGH	2043	2000	1893	1823	1726	1627	1503	1382	1249	1134
	MED	1706	1655	1593	1533	1450	1366	1265	1163	1062	950
	LOW	1452	1406	1373	1317	1245	1174	1112	1025	935	817
PBKD-LD15 * 115	HIGH	2053	1977	1899	1817	1725	1623	1519	1401	1265	1120
	MED	1711	1667	1606	1530	1458	1383	1284	1184	1066	951
	LOW	1460	1434	1407	1363	1310	1232	1137	1064	964	854
PBKD-LD20 * 130	HIGH	2330	2248	2177	2103	2024	1910	1789	1698	1555	1419
	MED	1867	1858	1814	1740	1675	1593	1524	1443	1330	1204
	LOW	1613	1531	1516	1490	1495	1411	1337	1250	1225	1010

Operation at these heating conditions exceed the listed temperature rise range. A higher blower speed must be selected.

* Model designator may be "N" for standard units, or "L" for factory built low NOx units.

CFM shown is with filter in place.

Airflow is expressed in standard cubic feet per minute.

Motor voltage at 115V