



TRANE[®]

TUX-D-2

Upflow/Horizontal Left Downflow/Horizontal Right Condensing, Direct Vent Gas-Fired Furnace

XR 90

TUX040,060,080,100,120C

TDX040,060,080,100,120C

**Single-Stage Fan Assisted
Combustion System**

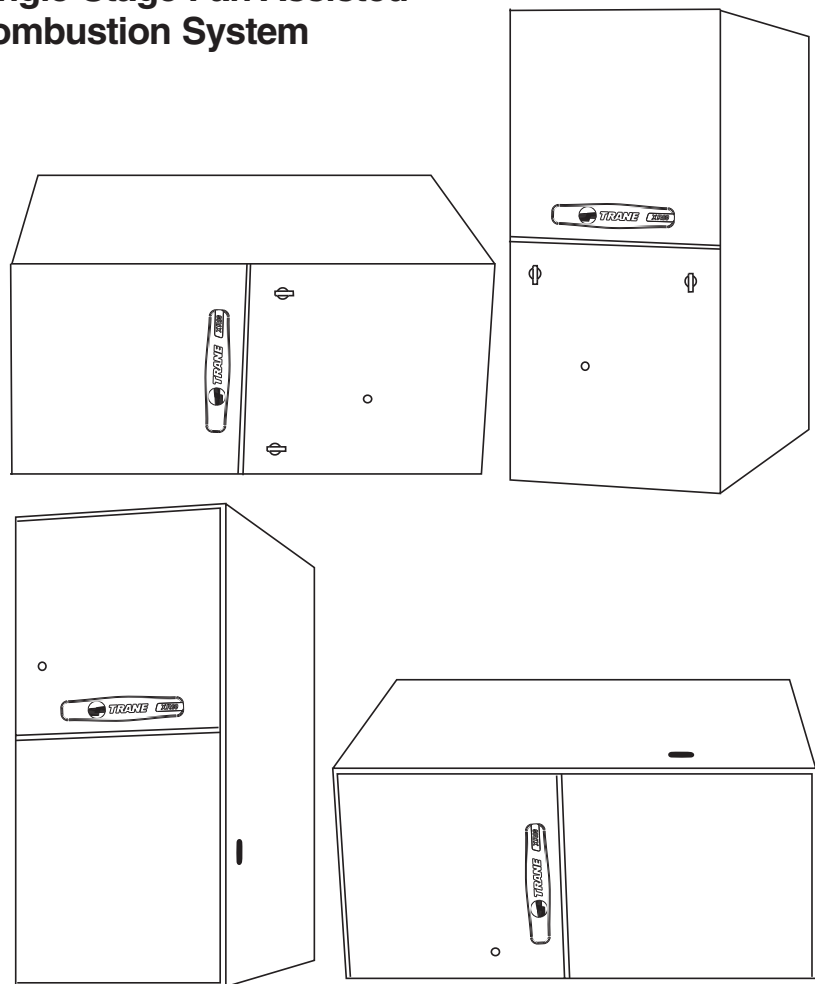

PUB. NO. 22-1674-04-0803 (EN)



General Features

NATURAL GAS MODELS

Central Heating furnace designs are certified by the American Gas Association for both natural and L.P. gas. Limit setting and rating data were established and approved under standard rating conditions using American National Standards Institute standards.

SAFE OPERATION

The Integrated System Control has solid state devices, which continuously monitor for presence of flame, when the system is in the heating mode of operation. Dual solenoid combination gas valve and regulator provide extra safety.

QUICK HEATING

Durable, cycle tested, heavy gauge **aluminized steel heat exchanger** quickly transfers heat to provide warm conditioned air to the structure. **Low energy power vent blower**, to increase efficiency and provide a positive discharge of gas fumes to the outside.

BURNERS

Multiport Inshot burners will give years of quiet and efficient service. All models can be converted to **L.P. gas** without changing burners.

INTEGRATED SYSTEM CONTROL

Exclusively designed operational program provides total control of furnace limit sensors, blowers, gas valve, flame control and includes self diagnostics for ease of service. Also contains connection points for E.A.C./humidifier.

AIR DELIVERY

The four speed, direct drive blower motor, has sufficient airflow for most heating and cooling requirements, will switch from heating to cooling speeds on demand from room thermostat. The blower door safety switch will prevent or terminate furnace operation when the blower door is removed.

STYLING

Heavy gauge steel and "wrap-around" cabinet construction is used in the cabinet with baked-on enamel finish for strength and beauty. The heat exchanger section of the cabinet is completely lined with foil faced fiberglass insulation. This results in quiet and efficient operation due to the excellent acoustical and insulating qualities of fiberglass. Built-in bottom pan and alternate bottom, left or right side return air connection provision.

FEATURES AND GENERAL OPERATION

The XR 90 High Efficiency Gas Furnaces employ a Silicon Carbide Hot Surface Ignition system, which eliminates the waste of a constant burning pilot. The integrated system control lights the main burners upon a demand for heat from the room thermostat. Complete front service access.

- a. Low energy power venter
- b. Vent proving pressure switch.

Features and Benefits

Contents

XR 90 Standard Equipment

- Power supply 115/1/60
- Convertible to horizontal left
- **Type 29-4C™** stainless steel secondary heat exchanger
- Inner blower doors
- Direct drive, 4-speed motors
- Silicon Nitride igniter with adaptive heat up
- Accessory hook-up capability – Hum and EAC
- Quiet induced draft blower
- Blower door safety switch
- Dual solenoid combination gas valve & regulator
- Cleanable high velocity filters
- PVC venting – 1 or 2 pipe vent option
- Left/right gas connection
- Selectable cooling fan off delay eliminates need for BAY24X045 time delay relay
- Single wire twinning
- Integrated solid state control with self-diagnostics
- 24 volt fuse
- Manual reset burner box limit
- **Lifetime limited primary heat exchanger or secondary heat exchanger warranty to original owner (Residential use)**
- **5 Year limited parts warranty**
- **Optional extended warranties**

General Features

Features and Benefits

- XR 90 Standard Equipment
- XR 90 Optional Equipment

General Data

- TUX040C924D
- TUX060C936D
- TUX080C942D
- TUX080C960D
- TUX100C948D
- TUX100C960D
- TUX120C960D
- TDX040C924D
- TDX060C936D
- TDX080C942D
- TDX100C948D
- TDX120C960D

Performance Data

Electrical Data

Field Wiring

Twinning Field Wiring

Dimensions

2
3
3
4
5
5
5
5
5
6
6
6
7
7
7
8
8
9
11
13
14
15



Features and Benefits

XR 90 Optional Equipment

Thermostat, Mechanical Heating Only Without Fan Switch	BAYSTAT388 []
Thermostat, Mechanical Heating Only With Fan Switch	BAYSTAT303 []
Thermostat, Heating/Cooling Single Stage (Mounts Horizontally)	AY28X092 []
Thermostat, Heating/Cooling Single Stage (Mounts Vertically)	BAYSTAT305 []
Thermostat, Electronic Programmable 1-Stage Heating/1-Stage Cooling	TAYSTAT300C []
Propane Conversion Kit	BAYLPKT210B []
Propane Conversion Kit (stainless steel burners)	BAYLPSS210B []
Wall Mount Flange – 3"	BAY96X147 []
Wall Mount Flange – 2"	BAY96X148 []
Downflow Subbase	BAYBASE205 []
Filter Access Door Kit	BAYFLTR206 []
Electronic Air Filter, "Perfect Fit" Super Efficiency (17-1/2" Wide Gas Furnace)	TFE175A9FR0 []
Electronic Air Filter, "Perfect Fit" Super Efficiency (21" Wide Gas Furnace)	TFE210A9FR0 []
Electronic Air Filter, "Perfect Fit" Super Efficiency (24-1/2" Wide Gas Furnace)	TFE245A9FR0 []
Electronic Air Filter, "Perfect Fit" High Efficiency (17-1/2" Wide Gas Furnace)	TFM175A9FR0 []
Electronic Air Filter, "Perfect Fit" High Efficiency (21" Wide Gas Furnace)	TFM210A9FR0 []
Electronic Air Filter, "Perfect Fit" High Efficiency (24-1/2" Wide Gas Furnace)	TFM245A9FR0 []
Electronic Air Filter, "Perfect Fit" Standard Efficiency (17-1/2" Wide Gas Furnace)	TFP175A9FR0 []
Electronic Air Filter, "Perfect Fit" Standard Efficiency (21" Wide Gas Furnace)	TFP210A9FR0 []
Electronic Air Filter, "Perfect Fit" Standard Efficiency (24-1/2" Wide Gas Furnace)	TFP245A9FR0 []
Side Filter Rack	BAYFLTR200 []
Coil Enclosure (17-1/2" Wide Cabinets)	BAYCLE1700C []
Coil Enclosure (21" Wide Cabinets)	BAYCLE2100C []
Coil Enclosure (24-1/2" Wide Cabinets)	BAYCLE2400C []
High Altitude Pressure Switch Kit TUX040,100C960D; TDX040C	BAYHALT230 []
High Altitude Pressure Switch Kit TUX060C	BAYHALT231 []
High Altitude Pressure Switch Kit TUX080C	BAYHALT232 []
High Altitude Pressure Switch Kit TUX100C948D,120C; TDX080,120C	BAYHALT233 []
High Altitude Pressure Switch Kit TDX100C	BAYHALT234 []
High Altitude Pressure Switch Kit TDX060C	BAYHALT241 []
Concentric Vent Kit	BAYVENT100A []
Sidewall Vent Termination Kit	BAYVENT200B []
Manufactured/Mobile Home Kit	BAYMFGH100A []



General Data

Product Specifications ^①

MODEL	TUX040C924D	TUX060C936D	TUX080C942D	TUX080C960D
TYPE	Upflow / Horizontal	Upflow / Horizontal	Upflow / Horizontal	Upflow / Horizontal
RATINGS ^②				
Input BTUH	40,000	60,000	80,000	80,000
Capacity BTUH (ICS) ^③	38,000	56,000	74,000	74,000
AFUE (ICS)	92.0	92.0	92.0	92.0
Temp. rise (Min.-Max.) °F.	30 - 60	30 - 60	35 - 65	30 - 60
BLOWER DRIVE	DIRECT	DIRECT	DIRECT	DIRECT
Diameter - Width (In.)	9 x 7	10 x 7	10 x 8	10 x 11
No. Used	1	1	1	1
Speeds (No.)	4	4	4	4
CFM vs. in. w.g.	See Fan Performance Table	See Fan Performance Table	See Fan Performance Table	See Fan Performance Table
Motor HP	1/5	1/3	1/3	3/4
R.P.M.	1075	1075	1075	1075
Volts / Ph / Hz	115/1/60	115/1/60	115/1/60	115/1/60
COMBUSTION FAN - Type	Centrifugal	Centrifugal	Centrifugal	Centrifugal
Drive - No. Speeds	Direct - 1	Direct - 1	Direct - 1	Direct - 1
Motor HP - RPM	1/55 - 3000	1/55 - 3000	1/24 - 3200	1/25 - 3200
Volts / Ph / Hz	115/1/60	115/1/60	115/1/60	115/1/60
FLA	1.0	1.0	1.35	1.35
FILTER — Furnished?	Yes	Yes	Yes	Yes
Type Recommended	High Velocity	High Velocity	High Velocity	High Velocity
Hi Vel. (No.-Size-Thk.)	1 - 17x25 - 1in.	1 - 17x25 - 1in.	1 - 17x25 - 1in.	1 - 20x25 - 1in.
VENT — Size (in.)	2 Round	2 Round	2 Round	2 Round
HEAT EXCHANGER				
Type-Fired	Aluminized Steel - Type I	Aluminized Steel - Type I	Aluminized Steel - Type I	Aluminized Steel - Type I
-Unfired				
Gauge (Fired)	20	20	20	20
ORIFICES — Main				
Nat. Gas. Qty. — Drill Size	2 — 45	3 — 45	4 — 45	4 — 45
L.P. Gas Qty. — Drill Size	2 — 56	3 — 56	4 — 56	4 — 56
GAS VALVE	Redundant - Single Stage	Redundant - Single Stage	Redundant - Single Stage	Redundant - Single Stage
PILOT SAFETY DEVICE				
Type	Hot Surface Ignition	Hot Surface Ignition	Hot Surface Ignition	Hot Surface Ignition
BURNERS — Type	Multiport Inshot	Multiport Inshot	Multiport Inshot	Multiport Inshot
Number	2	3	4	4
POWER CONN. — V / Ph / Hz ^④	115/1/60	115/1/60	115/1/60	115/1/60
Ampacity (In Amps)	4.8	8.4	9.5	13.5
Max. Overcurrent Protection (Amps)	15	15	15	20
PIPE CONN. SIZE (IN.)	1/2	1/2	1/2	1/2
DIMENSIONS	H x W x D	H x W x D	H x W x D	H x W x D
Crated (In.)	41-3/4 x 19-1/2 x 30-1/2	41-3/4 x 19-1/2 x 30-1/2	41-3/4 x 19-1/2 x 30-1/2	41-3/4 x 23 x 30-1/2
WEIGHT				
Shipping (Lbs.) / Net (Lbs)	139 / 129	150 / 140	158 / 148	171 / 160

① Central Furnace heating designs are certified by AGA and CSA.

② For U.S. applications, above input ratings (BTUH) are up to 2,000 feet, derate 4% per 1,000 feet for elevations above 2,000 feet above sea level. For Canadian applicaitons, above input ratings (BTUH) are up to 4,500 feet, derate 4% per 1,000 feet for elevations above 4,500 feet above sea level.

③ Based on U.S. government standard tests.

④ The above wiring specifications are in accordance with National Electrical Code; however, installations must comply with local codes.



General Data

Product Specifications ^①

MODEL	TUX100C948D	TUX100C960D	TUX120C960D
TYPE	Upflow / Horizontal	Upflow / Horizontal	Upflow / Horizontal
RATINGS ^②			
Input BTUH	100,000	100,000	120,000
Capacity BTUH (ICS) ^③	93,000	93,000	113,000
AFUE (ICS)	92.0	92.0	92.0
Temp. rise (Min.-Max.) °F.	35 - 65	35 - 65	40 - 70
BLOWER DRIVE	DIRECT	DIRECT	DIRECT
Diameter - Width (In.)	10 x 10	11 x 10	11 x 10
No. Used	1	1	1
Speeds (No.)	4	4	4
CFM vs. in. w.g.	See Fan Performance Table	See Fan Performance Table	See Fan Performance Table
Motor HP	1/2	3/4	3/4
R.P.M.	1075	1100	1100
Volts / Ph / Hz	115/1/60	115/1/60	115/1/60
COMBUSTION FAN - Type	Centrifugal	Centrifugal	Centrifugal
Drive - No. Speeds	Direct - 1	Direct - 1	Direct - 1
Motor HP - RPM	1/20 - 3450	1/20 - 3450	1/20 - 3450
Volts / Ph / Hz	115/1/60	115/1/60	115/1/60
FLA	0.71	0.71	0.71
FILTER — Furnished?	Yes	Yes	Yes
Type Recommended	High Velocity	High Velocity	High Velocity
Hi Vel. (No.-Size-Thk.)	1 - 20x25 - 1in.	1 - 24x25 - 1in.	1 - 24x25 - 1in.
VENT — Size (in.)	2 Round	2 Round	3 Round
HEAT EXCHANGER			
Type-Fired	Aluminized Steel - Type I	Aluminized Steel - Type I	Aluminized Steel - Type I
-Unfired			
Gauge (Fired)	20	20	20
ORIFICES — Main			
Nat. Gas Qty. — Drill Size	5 — 45	5 — 45	6 — 45
L.P. Gas Qty. — Drill Size	5 — 56	5 — 56	6 — 56
GAS VALVE	Redundant - Single Stage	Redundant - Single Stage	Redundant - Single Stage
PILOT SAFETY DEVICE			
Type	Hot Surface Ignition	Hot Surface Ignition	Hot Surface Ignition
BURNERS — Type	Multiport Inshot	Multiport Inshot	Multiport Inshot
Number	5	5	6
POWER CONN. — V / Ph / Hz ^④	115/1/60	115/1/60	115/1/60
Ampacity (In Amps)	12.5	12.9	12.9
Max. Overcurrent Protection (Amps)	15	15	15
PIPE CONN. SIZE (IN.)	1/2	1/2	1/2
DIMENSIONS	H x W x D	H x W x D	H x W x D
Crated (In.)	41-3/4 x 23 x 30-1/2	41-3/4 x 26-1/2 x 30-1/2	41-3/4 x 26-1/2 x 30-1/2
WEIGHT			
Shipping (Lbs.) / Net (Lbs)	171 / 160	197 / 185	205 / 193

① Central Furnace heating designs are certified by AGA and CSA.

② For U.S. applications, above input ratings (BTUH) are up to 2,000 feet, derate 4% per 1,000 feet for elevations above 2,000 feet above sea level. For Canadian applicaitons, above input ratings (BTUH) are up to 4,500 feet, derate 4% per 1,000 feet for elevations above 4,500 feet above sea level.

③ Based on U.S. government standard tests.

④ The above wiring specifications are in accordance with National Electrical Code; however, installations must comply with local codes.



General Data

Product Specifications ^①

MODEL	TDX040C924D	TDX060C936D	TDX080C942D
TYPE	Downflow / Horizontal	Downflow / Horizontal	Downflow / Horizontal
RATINGS ^②			
Input BTUH	40,000	60,000	80,000
Capacity BTUH (ICS) ^③	38,000	56,000	74,000
AFUE (ICS)	91.0	91.0	91.0
Temp. rise (Min.-Max.) °F.	30 - 60	30 - 60	35 - 65
BLOWER DRIVE	DIRECT	DIRECT	DIRECT
Diameter - Width (In.)	10 x 7	10 x 8	11 x 8
No. Used	1	1	1
Speeds (No.)	4	4	4
CFM vs. in. w.g.	See Fan Performance Table	See Fan Performance Table	See Fan Performance Table
Motor HP	1/5	1/3	1/2
R.P.M.	1080	1075	1075
Volts / Ph / Hz	115/1/60	115/1/60	115/1/60
COMBUSTION FAN - Type	Centrifugal	Centrifugal	Centrifugal
Drive - No. Speeds	Direct - 1	Direct - 1	Direct - 1
Motor HP - RPM	1/55 - 3000	1/55 - 3000	1/25 - 3200
Volts / Ph / Hz	115/1/60	115/1/60	115/1/60
FLA	1.14	1.0	1.35
FILTER — Furnished?	Yes	Yes	Yes
Type Recommended	High Velocity	High Velocity	High Velocity
Hi Vel. (No.-Size-Thk.)	2 - 14x20 - 1in.	2 - 14x20 - 1in.	2 - 14x20 - 1in.
VENT — Size (in.)	2 Round	2 Round	2 Round
HEAT EXCHANGER			
Type-Fired	Aluminized Steel - Type I	Aluminized Steel - Type I	Aluminized Steel - Type I
-Unfired			
Gauge (Fired)	20	20	20
ORIFICES — Main			
Nat. Gas Qty. — Drill Size	2 — 45	3 — 45	4 — 45
L.P. Gas Qty. — Drill Size	2 — 56	3 — 56	4 — 56
GAS VALVE	Redundant - Single Stage	Redundant - Single Stage	Redundant - Single Stage
PILOT SAFETY DEVICE			
Type	Hot Surface Ignition	Hot Surface Ignition	Hot Surface Ignition
BURNERS — Type	Multiport Inshot	Multiport Inshot	Multiport Inshot
Number	2	3	4
POWER CONN. — V / Ph / Hz ^④	115/1/60	115/1/60	115/1/60
Ampacity (In Amps)	4.8	9.2	11.4
Max. Overcurrent Protection (Amps)	15	15	15
PIPE CONN. SIZE (IN.)	1/2	1/2	1/2
DIMENSIONS	H x W x D	H x W x D	H x W x D
Crated (In.)	41-3/4 x 19-1/2 x 30-1/2	41-3/4 x 19-1/2 x 30-1/2	41-3/4 x 19-1/2 x 30-1/2
WEIGHT			
Shipping (Lbs.) / Net (Lbs)	145 / 135	155 / 145	168 / 158

① Central Furnace heating designs are certified by AGA and CSA.

② For U.S. applications, above input ratings (BTUH) are up to 2,000 feet, derate 4% per 1,000 feet for elevations above 2,000 feet above sea level. For Canadian applicaitons, above input ratings (BTUH) are up to 4,500 feet, derate 4% per 1,000 feet for elevations above 4,500 feet above sea level.

③ Based on U.S. government standard tests.

④ The above wiring specifications are in accordance with National Electrical Code; however, installations must comply with local codes.



General Data

Product Specifications ①

MODEL	TDX100C948D	TDX120C960D
TYPE	Downflow / Horizontal	Downflow / Horizontal
RATINGS ②		
Input BTUH	100,000	120,000
Capacity BTUH (ICS) ③	94,000	110,000
AFUE (ICS)	91.0	91.0
Temp. rise (Min.-Max.) °F.	35 - 65	40 - 70
BLOWER DRIVE	DIRECT	DIRECT
Diameter - Width (In.)	11 x 10	11 x 10
No. Used	1	1
Speeds (No.)	4	4
CFM vs. in. w.g.	See Fan Performance Table	See Fan Performance Table
Motor HP	1/2	3/4
R.P.M.	1075	1075
Volts / Ph / Hz	115/1/60	115/1/60
COMBUSTION FAN - Type	Centrifugal	Centrifugal
Drive - No. Speeds	Direct - 1	Direct - 1
Motor HP - RPM	1/20 - 3450	1/20 - 3450
Volts / Ph / Hz	115/1/60	115/1/60
FLA	0.71	0.71
FILTER — Furnished?	Yes	Yes
Type Recommended	High Velocity	High Velocity
Hi Vel. (No.-Size-Thk.)	2 - 16x20 - 1in.	2 - 16x20 - 1in.
VENT — Size (in.)	2 Round	3 Round
HEAT EXCHANGER		
Type-Fired	Aluminized Steel - Type I	Aluminized Steel - Type I
-Unfired		
Gauge (Fired)	20	20
ORIFICES — Main		
Nat. Gas Qty. — Drill Size	5 — 45	6 — 45
L.P. Gas Qty. — Drill Size	5 — 56	6 — 56
GAS VALVE	Redundant - Single Stage	Redundant - Single Stage
PILOT SAFETY DEVICE		
Type	Hot Surface Ignition	Hot Surface Ignition
BURNERS — Type	Multiport Inshot	Multiport Inshot
Number	5	6
POWER CONN. — V / Ph / Hz ④	115/1/60	115/1/60
Ampacity (In Amps)	13.6	13.9
Max. Overcurrent Protection (Amps)	20	20
PIPE CONN. SIZE (IN.)	1/2	1/2
DIMENSIONS	H x W x D	H x W x D
Crated (In.)	41-3/4 x 23 x 30-1/2	41-3/4 x 26-1/2 x 30-1/2
WEIGHT		
Shipping (Lbs.) / Net (Lbs)	185 / 175	206 / 196

① Central Furnace heating designs are certified by AGA and CSA.

② For U.S. applications, above input ratings (BTUH) are up to 2,000 feet, derate 4% per 1,000 feet for elevations above 2,000 feet above sea level. For Canadian applicaitons, above input ratings (BTUH) are up to 4,500 feet, derate 4% per 1,000 feet for elevations above 4,500 feet above sea level.

③ Based on U.S. government standard tests.

④ The above wiring specifications are in accordance with National Electrical Code; however, installations must comply with local codes.



Performance Data

FURNACE AIRFLOW (CFM) VS. EXTERNAL STATIC PRESSURE (in. w.c.)										
MODEL	SPEED TAP	0.10	0.20	0.30	0.40	0.50	0.60	0.70	0.80	0.90
TUX040C924D	4 - HIGH - Black	1043	992	930	885	812	740	647	518	457
	3 - MED.-HIGH - Blue	940	895	841	791	726	650	559	420	390
	2 - MED.-LOW - Yellow	837	798	752	705	649	560	438	305	279
	1 - LOW - Red	729	694	657	600	545	478	376	220	178
TUX060C936D	4 - HIGH - Black	1394	1359	1314	1260	1196	1122	1038	945	853
	3 - MED.-HIGH - Blue	1250	1232	1202	1160	1106	1040	962	873	771
	2 - MED.-LOW - Yellow	1102	1092	1069	1034	986	925	852	766	668
	1 - LOW - Red	957	944	922	891	853	806	750	686	614
TUX080C942D	4 - HIGH - Black	1748	1683	1615	1544	1470	1393	1314	1232	1147
	3 - MED.-HIGH - Blue	1375	1367	1347	1314	1268	1210	1139	1056	960
	2 - MED.-LOW - Yellow	1178	1167	1147	1119	1082	1036	982	919	847
	1 - LOW - Red	859	863	856	839	811	772	723	663	592
TUX080C960D	4 - HIGH - Black	2304	2262	2219	2170	2121	2048	1975	1893	1811
	3 - MED.-HIGH - Blue	1980	1963	1946	1919	1892	1853	1814	1751	1687
	2 - MED.-LOW - Yellow	1668	1654	1640	1626	1611	1587	1562	1511	1460
	1 - LOW - Red	1375	1372	1368	1361	1354	1330	1305	1267	1229
TUX100C948D	4 - HIGH - Black	2054	1980	1906	1826	1746	1649	1551	1428	1305
	3 - MED.-HIGH - Blue	1932	1875	1818	1746	1673	1577	1481	1371	1260
	2 - MED.-LOW - Yellow	1762	1720	1677	1615	1552	1463	1373	1266	1158
	1 - LOW - Red	1558	1546	1533	1477	1421	1350	1278	1175	1071
TUX100C960D	4 - HIGH - Black	2411	2358	2304	2235	2165	2083	2001	1915	1828
	3 - MED.-HIGH - Blue	2108	2083	2058	2007	1956	1893	1829	1754	1679
	2 - MED.-LOW - Yellow	1772	1759	1745	1723	1700	1657	1613	1544	1475
	1 - LOW - Red	1480	1477	1474	1458	1441	1414	1386	1327	1268
TUX120C960D	4 - HIGH - Black	2454	2406	2358	2310	2261	2184	2106	2017	1928
	3 - MED.-HIGH - Blue	2105	2092	2078	2045	2012	1950	1887	1826	1765
	2 - MED.-LOW - Yellow	1747	1742	1736	1720	1703	1677	1651	1593	1535
	1 - LOW - Red	1445	1447	1449	1440	1430	1400	1369	1325	1280

NOTE: See page 11 for factory heat & cool speed tap settings

From D330656 Sh.1 Rev. 12

CFM VS. TEMPERATURE RISE																		
MODEL	Cubic Feet Per Minute (CFM)																	
	600	700	800	900	1000	1100	1200	1300	1400	1500	1600	1700	1800	1900	2000	2100	2200	
TUX040C924	56	48	42	37	33													
TUX060C936				56	50	45	42	39	36									
TUX080C942						61	56	51	48	44	42							
TUX080C960						61	56	51	48	44	42	39	37	35	33	32	30	
TUX100C948								64	60	56	52	49	46	44	42			
TUX100C960								64	60	56	52	49	46	44	42	40	38	
TUX120C960												63	59	56	53	50	48	46

From C340405 Sh. 1 Rev. 5



Performance Data

FURNACE AIRFLOW (CFM) VS. EXTERNAL STATIC PRESSURE (in. w.c.)										
MODEL	SPEED TAP	0.10	0.20	0.30	0.40	0.50	0.60	0.70	0.80	0.90
TDX040C924D	4 - HIGH - Black	998	965	922	870	807	735	653	561	459
	3 - MED.-HIGH - Blue	856	832	797	751	695	628	550	462	363
	2 - MED.-LOW - Yellow	753	728	694	650	596	533	460	378	286
	1 - LOW - Red	647	617	581	538	490	435	375	308	235
TDX060C936D	4 - HIGH - Black	1487	1425	1362	1286	1209	1125	1040	935	830
	3 - MED.-HIGH - Blue	1342	1291	1240	1182	1124	1047	989	869	769
	2 - MED.-LOW - Yellow	1181	1147	1113	1061	1009	943	877	779	681
	1 - LOW - Red	877	863	849	820	791	739	686	612	537
TDX080C942D	4 - HIGH - Black	1547	1498	1445	1386	1323	1254	1180	1101	1016
	3 - MED.-HIGH - Blue	1487	1436	1382	1325	1265	1202	1137	1069	998
	2 - MED.-LOW - Yellow	1388	1348	1302	1249	1191	1126	1056	979	896
	1 - LOW - Red	1263	1234	1196	1150	1095	1032	960	879	790
TDX100C948D	4 - HIGH - Black	1892	1827	1762	1688	1614	1531	1448	1354	1260
	3 - MED.-HIGH - Blue	1779	1726	1672	1605	1538	1460	1381	1291	1200
	2 - MED.-LOW - Yellow	1630	1587	1544	1485	1426	1362	1297	1208	1119
	1 - LOW - Red	1444	1416	1388	1348	1308	1246	1184	1108	1032
TDX120C960D	4 - HIGH - Black	2213	2138	2062	2001	1939	1863	1786	1706	1625
	3 - MED.-HIGH - Blue	2057	2000	1943	1883	1822	1752	1681	1595	1508
	2 - MED.-LOW - Yellow	1765	1733	1700	1652	1603	1552	1500	1424	1347
	1 - LOW - Red	1468	1452	1435	1409	1382	1336	1290	1225	1159

From D330710 Rev.10

CFM VS. TEMPERATURE RISE																			
MODEL	Cubic Feet Per Minute (CFM)																		
	600	700	800	900	1000	1100	1200	1300	1400	1500	1600	1700	1800	1900	2000	2100	2200	2300	2400
TDX040C924D	56	48	42	37	34														
TDX060C936D			63	56	51	46	42	39	36	34									
TDX080C942D						61	56	52	48	45	42	40	37	35					
TDX100C948D								65	60	56	53	50	47	44	42	40	38	37	35
TDX120C960D										67	63	59	56	53	51	48	46	44	42

From C330767 Sh. 1 Rev. 3

Electrical Data

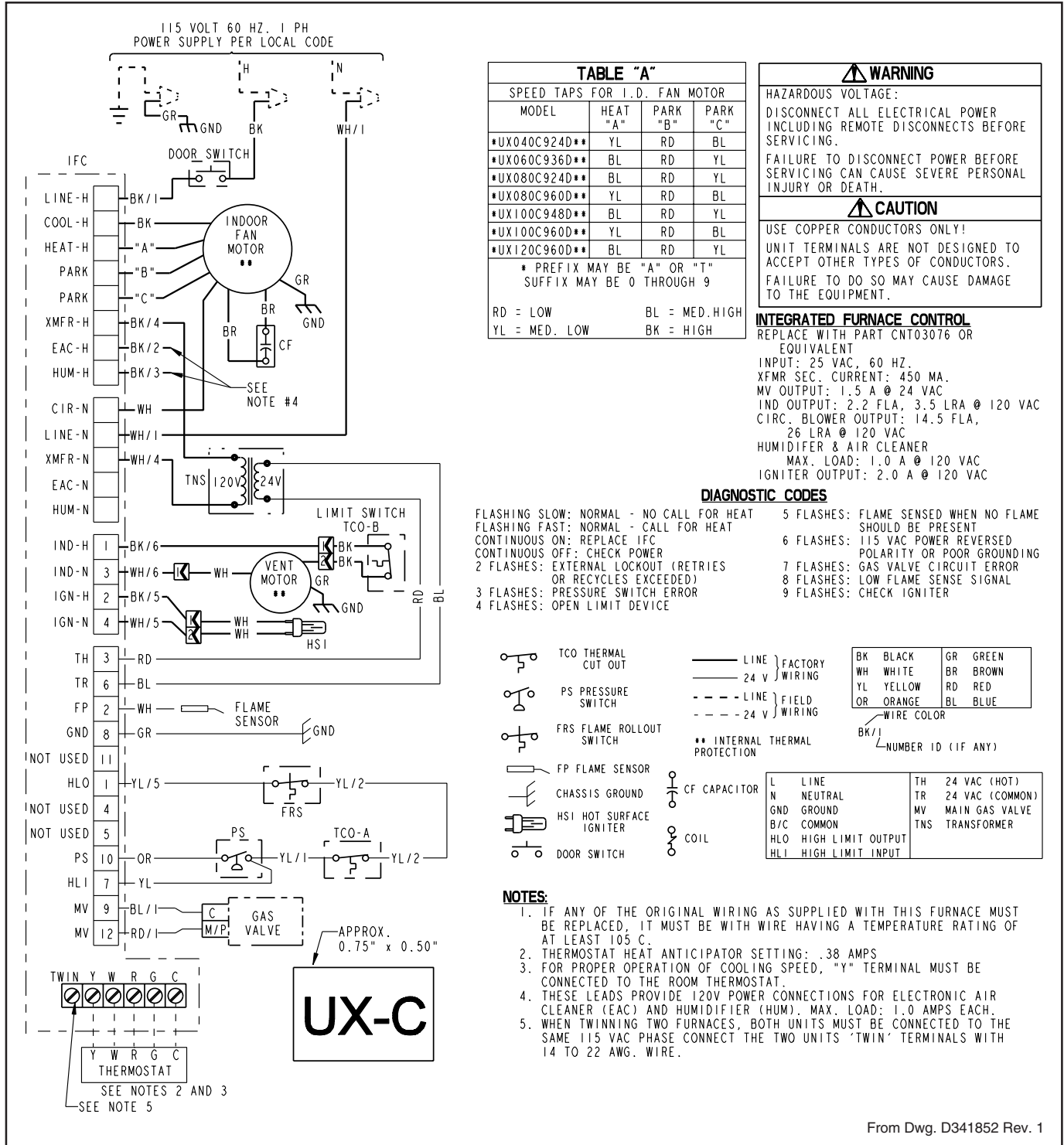

From Dwg. D341852 Rev. 1

Electrical Data

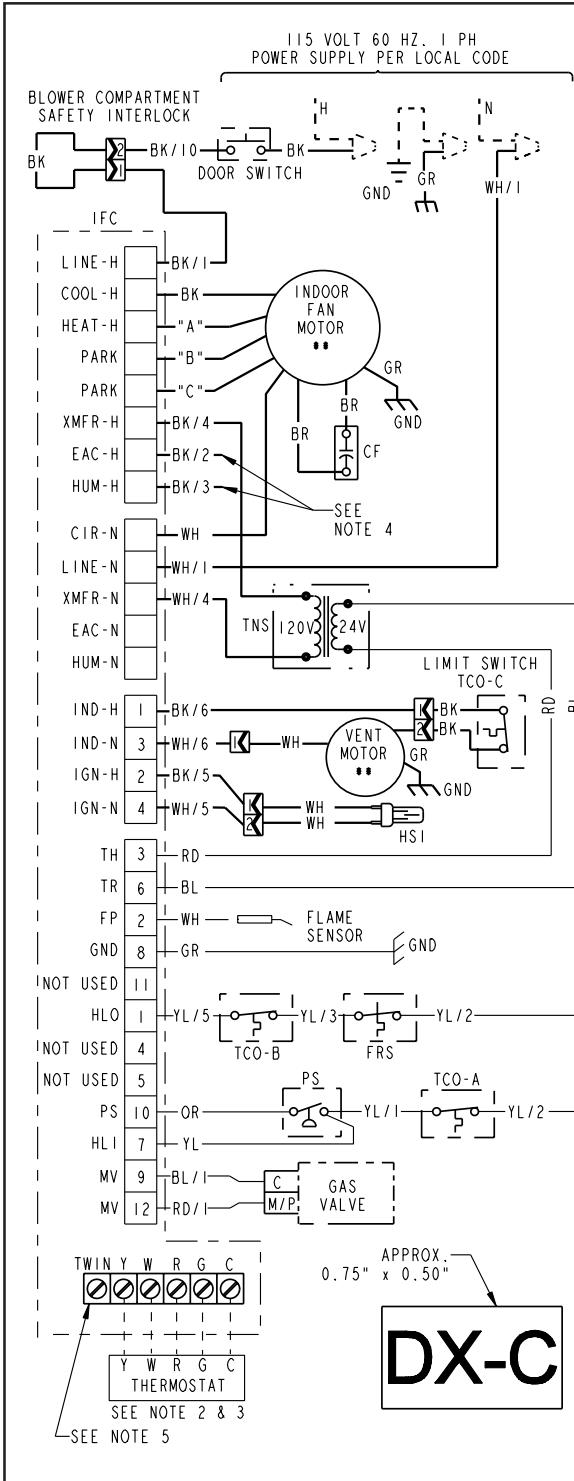

TABLE "A"
SPEED TAPS FOR I.D. FAN MOTOR

MODEL	HEAT "A"	PARK "B"	PARK "C"
*DX040C924D**	YL	RD	BL
*DX060C936D**	YL	RD	BL
*DX080C942D**	BL	RD	YL
*DX100C948D**	BL	RD	YL
*DX120C960D**	BL	RD	YL

RD = LOW BL = MED. HIGH
YL = MED. LOW BK = HIGH

* - MAY BE PREFIX "A" OR "T"
** - MAY BE SUFFIX 0 THROUGH 9

WARNING
HAZARDOUS VOLTAGE:
DISCONNECT ALL ELECTRICAL POWER INCLUDING REMOTE DISCONNECTS BEFORE SERVICING.
FAILURE TO DISCONNECT POWER BEFORE SERVICING CAN CAUSE SEVERE PERSONAL INJURY OR DEATH.

CAUTION
USE COPPER CONDUCTORS ONLY!
UNIT TERMINALS ARE NOT DESIGNED TO ACCEPT OTHER TYPES OF CONDUCTORS.
FAILURE TO DO SO MAY CAUSE DAMAGE TO THE EQUIPMENT.

INTEGRATED FURNACE CONTROL
REPLACE WITH PART CNT03076 OR EQUIVALENT
INPUT: 25 VAC, 60 HZ.
XFMR SEC. CURRENT: 450 MA.
MV OUTPUT: 1.5 A @ 24 VAC
IND OUTPUT: 2.2 FLA, 3.5 LRA @ 120 VAC
CIRC. BLOWER OUTPUT: 14.5 FLA, 26.0 LRA @ 120 VAC
HUMIDIFIER & AIR CLEANER
MAX. LOAD: 1.0 A @ 120 VAC
IGNITER OUTPUT: 6.0 A @ 120 VAC

DIAGNOSTIC CODES

FLASHING SLOW: NORMAL - NO CALL FOR HEAT
FLASHING FAST: NORMAL - CALL FOR HEAT
CONTINUOUS ON: REPLACE IFC
CONTINUOUS OFF: CHECK POWER
2 FLASHES: EXTERNAL LOCKOUT (RETRIES OR RECYCLES EXCEEDED)
3 FLASHES: PRESSURE SWITCH ERROR
4 FLASHES: OPEN LIMIT DEVICE

5 FLASHES: FLAME SENSED WHEN NO FLAME SHOULD BE PRESENT
6 FLASHES: 115 VAC POWER REVERSED POLARITY OR POOR GROUNDING
7 FLASHES: GAS VALVE CIRCUIT ERROR
8 FLASHES: LOW FLAME SENSE SIGNAL
9 FLASHES: CHECK IGNITER

LEGEND

TCO THERMAL CUT OUT
PS PRESSURE SWITCH
FRS FLAME ROLLOUT SWITCH
FP FLAME SENSOR
CHASSIS GROUND
HSI HOT SURFACE IGNITER
DOOR SWITCH

LINE 24 V WIRING
FIELD WIRING 24 V

** INTERNAL THERMAL PROTECTION

CF CAPACITOR
COIL

WIRE COLOR
BK BLACK, WH WHITE, YL YELLOW, OR ORANGE, GR GREEN, BR BROWN, RD RED, BL BLUE

BK/1 - NUMBER 1D (IF ANY)

TERMINAL BLOCK
L LINE, N NEUTRAL, GND GROUND, B/C COMMON, HLO HIGH LIMIT OUTPUT, HLI HIGH LIMIT INPUT, TH 24 VAC (HOT), TR 24 VAC (COMMON), MV MAIN GAS VALVE, TNS TRANSFORMER

NOTES:

- IF ANY OF THE ORIGINAL WIRING AS SUPPLIED WITH THIS FURNACE MUST BE REPLACED, IT MUST BE WITH WIRE HAVING A TEMPERATURE RATING OF AT LEAST 105 C.
- THERMOSTAT HEAT ANTICIPATOR SETTING: .38 AMPS
- FOR PROPER OPERATION OF COOLING SPEED, "Y" TERMINAL MUST BE CONNECTED TO THE ROOM THERMOSTAT.
- THESE LEADS PROVIDE 120V POWER CONNECTIONS FOR ELECTRONIC AIR CLEANER (EAC) AND HUMIDIFIER (HUM). MAX. LOAD: 1.0 AMPS EACH.
- WHEN TWINNING TWO FURNACES, BOTH UNITS MUST BE CONNECTED TO THE SAME 115 VAC PHASE CONNECT THE TWO UNITS "TWIN" TERMINALS WITH 14 TO 22 AWG. WIRE.

Field Wiring

FIELD WIRING DIAGRAM FOR 1 STAGE FURNACE 1 STAGE HEATING USING A 1 STAGE HEATING THERMOSTAT NO COOLING

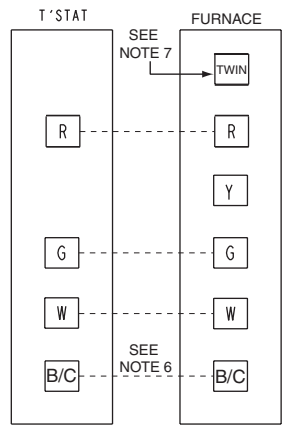

INTER-COMPONENT WIRING

----- 24 V. } FIELD WIRING
 ———— LINE V. }
 ----- 24 V. } FACTORY WIRING
 ———— LINE V. }

NOTES:

1. BE SURE POWER AGREES WITH EQUIPMENT NAMEPLATE(S).
2. LOW VOLTAGE (24V. WIRING) TO BE NO. 18 A.W.G. MIN.
3. GROUNDING OF EQUIPMENT MUST COMPLY WITH LOCAL CODES.
4. SET THERMOSTAT HEAT ANTICIPATOR PER UNIT WIRING DIAGRAM.
5. THESE LEADS PROVIDE 115 V. POWER FOR CONNECTION OF ELECTRONIC AIR CLEANER AND HUMIDIFIER MAX. LOAD 1.0 AMPS EACH.
6. THIS CONNECTION IS ONLY USED FOR THERMOSTATS REQUIRING CONNECTION TO THE 24 V. POWER SUPPLY. (COMMON)
7. SEE TWINNING CONNECTION DIAGRAMS FOR PROPER CONNECTIONS WHEN USING THIS FEATURE.

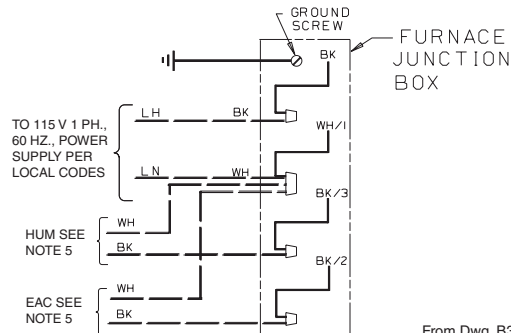

From Dwg. B341437 Rev. 1

FIELD WIRING DIAGRAM FOR 1 STAGE FURNACE 1 STAGE HEATING, 1 STAGE COOLING USING A 1 STAGE HEATING, 1 STAGE COOLING THERMOSTAT (OUTDOOR SECTION WITHOUT TRANSFORMER)

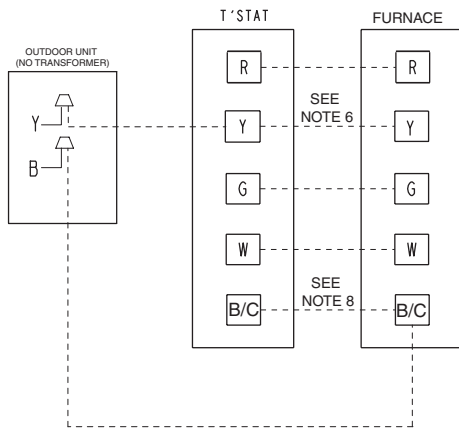

INTER-COMPONENT WIRING

----- 24 V. } FIELD WIRING
 ———— LINE V. }
 ----- 24 V. } FACTORY WIRING
 ———— LINE V. }

NOTES:

1. BE SURE POWER AGREES WITH EQUIPMENT NAMEPLATE(S)
2. LOW VOLTAGE(24 V. WIRING) TO BE NO. 18 A.W.G. MIN.
3. GROUNDING OF EQUIPMENT MUST COMPLY WITH LOCAL CODES.
4. SET THERMOSTAT HEAT ANTICIPATOR PER UNIT WIRING DIAGRAM.
5. THESE LEADS PROVIDE 115 V. POWER FOR CONNECTION OF ELECTRONIC AIR CLEANER AND HUMIDIFIER MAX. LOAD 1.0 AMPS EACH.
6. THE "Y" TERMINAL FROM THE THERMOSTAT MUST BE WIRED TO THE "Y" TERMINAL OF THE FURNACE CONTROL FOR PROPER BLOWER OPERATION DURING COOLING.
7. IGNITION CONTROL IS POLARITY SENSITIVE. HOT LEG OF 120 VOLT POWER SUPPLY MUST BE CONNECTED TO THE BLACK LINE POWER LEAD AS INDICATED ON THE WIRING DIAGRAM OR IGNITION LOCKOUT WILL OCCUR.
8. THIS CONNECTION IS ONLY USED FOR THERMOSTATS REQUIRING CONNECTION TO THE 24 V. POWER SUPPLY. (COMMON)

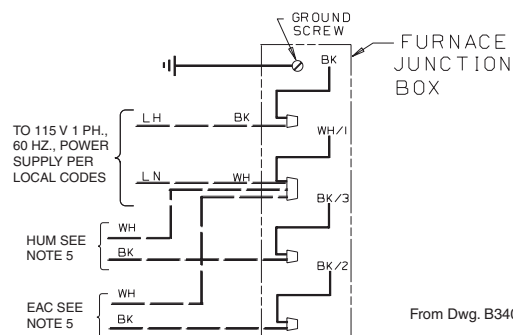

From Dwg. B340388 Rev. 2

Twinning Field Wiring

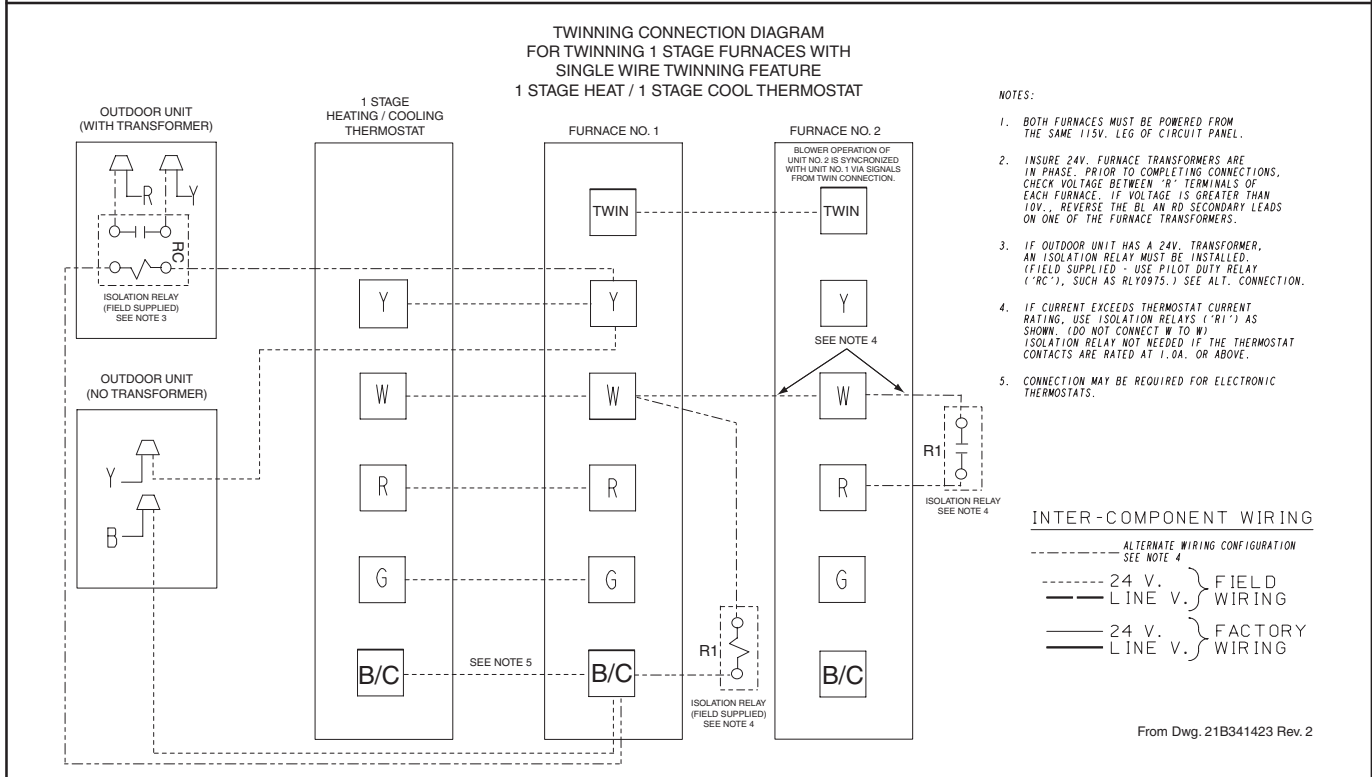
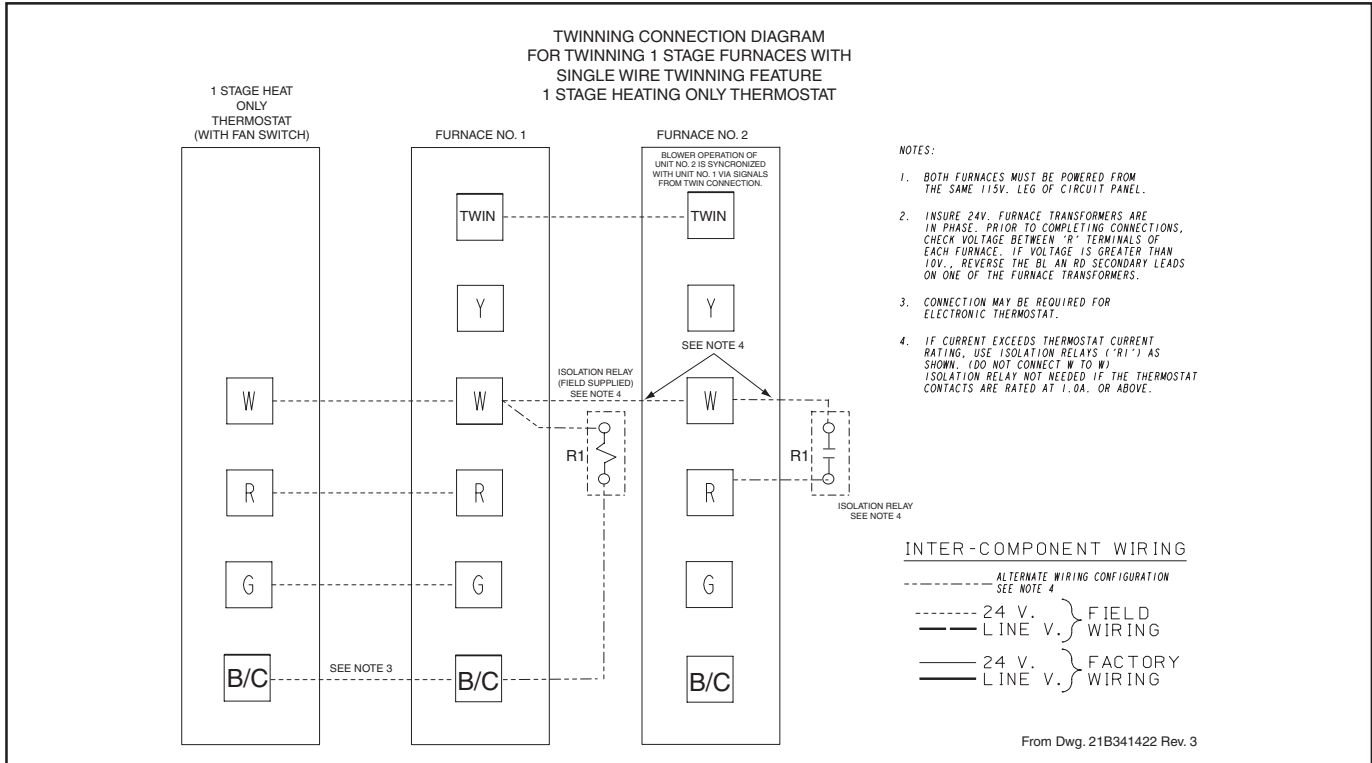

Dimensions

TUX-C-D Outline Drawing
(ALL DIMENSIONS ARE IN INCHES)

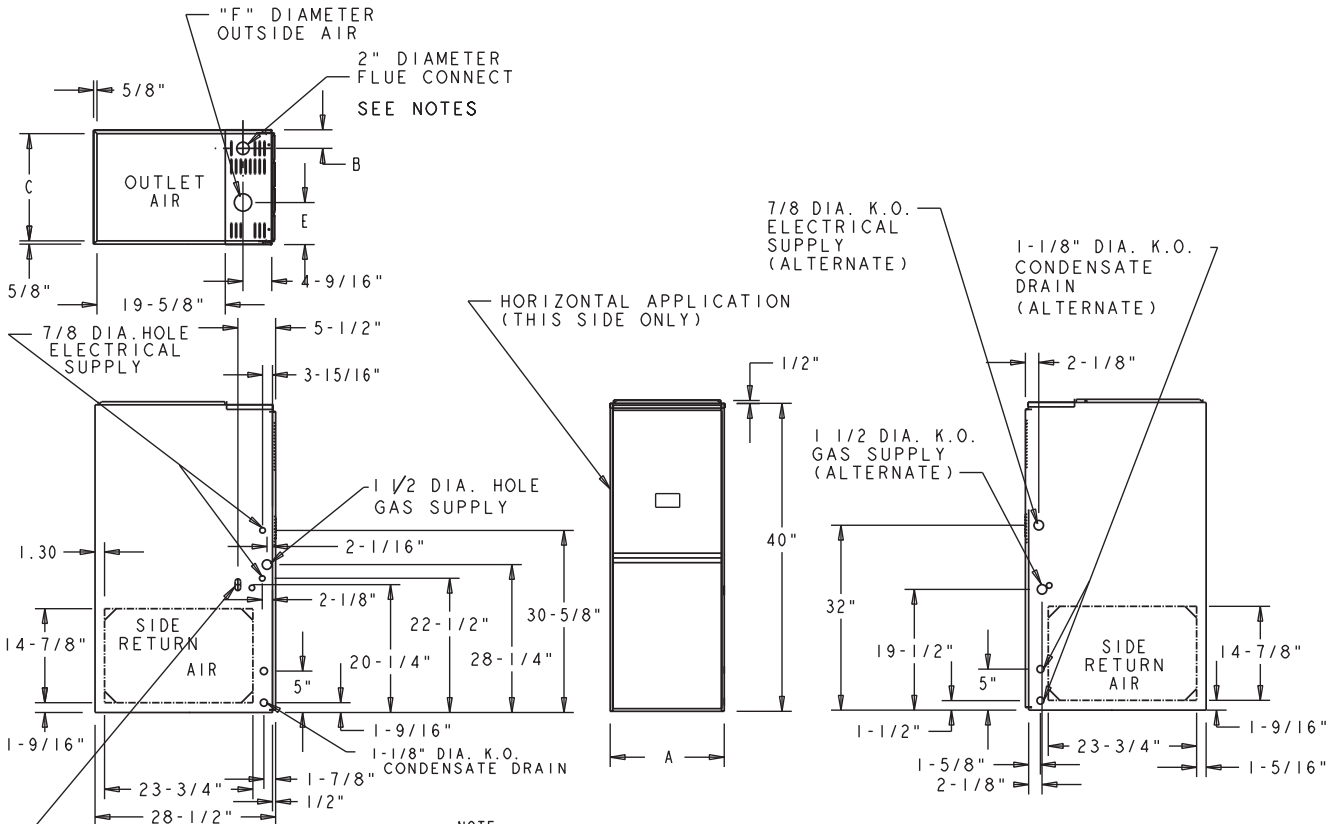

NOTE:
 1. *UX120C960 REQUIRES 3" DIAMETER VENT PIPE.
 2. *UX100C948 & *UX100C960 REQUIRES 2-1/2" OR 3" DIAMETER VENT PIPE.



MINIMUM CLEARANCE TO COMBUSTIBLE MATERIALS UPFLOW	
SIDES	0"
REAR	0"
FRONT	3"
TOP	1"
FLUE	0"

HORIZONTAL (FLUE DISCHARGE ON THE LEFT)	
ALCOVE SIDES	
RIGHT	0"
LEFT	0"
REAR	6"
FRONT	18"
TOP	1"
FLUE	0"
CLOSET SIDES	
RIGHT	1"
LEFT	1"
REAR	3"
FRONT	3"
TOP	1"
FLUE	0"

MODEL	A	B	C	D	E	F
TUX040C924 TUX060C936 TUX080C942	17-1/2"	2-1/4"	16-1/4"	16"	7-1/2"	2"
TUX080C960 TUX100C948	21"	2-1/2"	19-3/4"	19-1/2"	9"	3"
TUX100C960 TUX120C960	24-1/2"	2-15/16"	23-1/4"	23"	10"	3"

From Dwg. 21C340574 Rev. 12



Dimensions

TDX-C-D Outline Drawing
(ALL DIMENSIONS ARE IN INCHES)

MODEL (SEE NOTE 1)	DIM "A"	DIM "B"	DIM "C"	DIM "D"
*DX040C924** *DX060C936** *DX080C942**	17-1/2"	2-1/4"	16-1/4"	16"
*DX100C948**	21"	2-1/2"	19-3/4"	19-1/2"
*DX120C960**	24-1/2"	2-15/16"	23-1/4"	23"

* PREFIX MAY BE "A" OR "T"
 ** SUFFIX LETTER MAY BE "D" - 0 THRU 9
 *** SUFFIX LETTER MAY BE "W" - 0 THRU 9

NOTES:
 1. DIAMETER OF VENT PIPE MAY BE LIMITED TO 2-1/2" OR 3" ON SOME MODELS AT DIFFERENT ALTITUDES. REFER TO THE VENT LENGTH TABLE FOR PROPER APPLICATION.

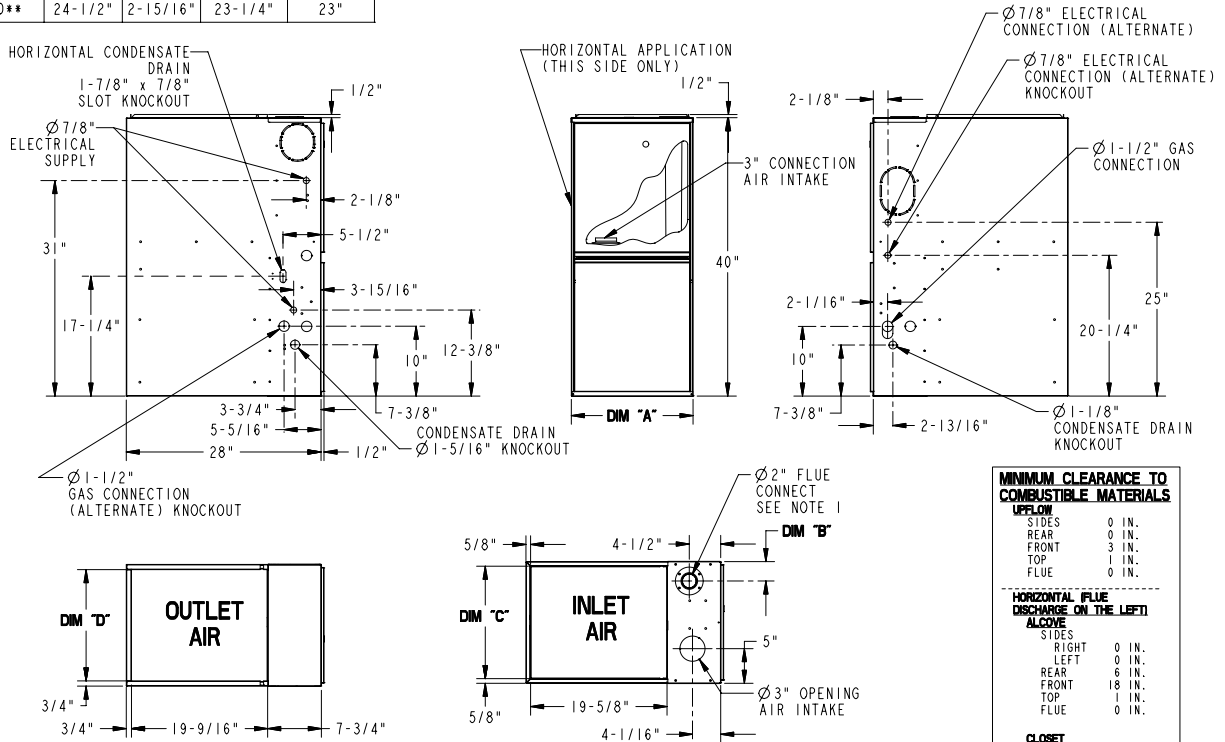

MINIMUM CLEARANCE TO COMBUSTIBLE MATERIALS	
UPFLOW	
SIDES	0 IN.
REAR	0 IN.
FRONT	3 IN.
TOP	1 IN.
FLUE	0 IN.
HORIZONTAL FLUE DISCHARGE ON THE LEFT	
ALCOVE	
SIDES	
RIGHT	0 IN.
LEFT	0 IN.
REAR	6 IN.
FRONT	18 IN.
TOP	1 IN.
FLUE	0 IN.
CLOSET	
SIDES	
RIGHT	1 IN.
LEFT	1 IN.
REAR	3 IN.
FRONT	3 IN.
TOP	1 IN.
FLUE	0 IN.

From Dwg. 21C341885 Rev. 0



Trane
 A business of
 American Standard Companies
www.trane.com

Literature Order Number	TUX-D-2	P.I.
File Number	PL-UN-FURN-TUX-D-2 08/03	
Supersedes	TUX-D-1 06/02	
Stocking Location	PI Louisville	

Trane has a policy of continuous product and product data improvement and it reserves the right to change design and specifications without notice.